

Cost Accounting - IV

(As Per the Revised Syllabus 2018-19 of University of Mumbai for
BAF, Semester VI)

Winner of “Best Commerce Author – 2013-14” by Maharashtra Commerce Association
“State Level Mahatma Jyotiba Phule Excellent Teacher Award 2016”

Maharashtra Guru Gaurav Award 2016-17
State Level Exemplary Teacher Award 2017-2018
Swami Vivekanand Human Science Award 2018-19

Dr. Nishikant Jha

ICWA, PGDM (MBA), M.Com., Ph.D., D.Litt. [USA],
CIMA Advocate [CIMA U.K.], BEC [Cambridge University],
International Executive MBA [UBI Brussels, Belgium, Europe],
Recognised UG & PG Professor by University of Mumbai.
Recognised M.Phil. & Ph.D. Guide by University of Mumbai.
Assistant Professor in Accounts & HOD, BAF, Thakur College of Science & Commerce.
Visiting Faculty in K.P.B. Hinduja College for M.Phil. & M.Com., University of Mumbai.
CFA & CPF (USA), CIMA (UK), Indian & International MBA, CA & CS Professional Course.

Rajiv S. Mishra

M.Com., MBA, M.Phil., UGC NET,
Assistant Professor at N.E.S. Ratnam College of Arts, Science & Commerce for BBI &
Coordinator for M.Com., Bhandup (W), Mumbai – 400078.
Visiting Faculty at Nitin Godiwala, Chandrabhan Sharma, S.M. Shetty College,
N.G. Acharya, V.K. Menon College, Sikkim Manipal University &
Vikas College for M.Com., MBA, BBI, BMS, BFM & BAF.

Ms. Ruchi Negi

M.Com., M.Phil.
Assistant Professor,
Thakur College of Science & Commerce.



Himalaya Publishing House

ISO 9001:2015 CERTIFIED

© **Authors**

No part of this publication may be reproduced, stored in a retrieval system, or transmitted in any form or by any means, electronic, mechanical, photocopying, recording and/or otherwise without the prior written permission of the publisher.

First Edition : 2017

Second Revised Edition : 2019

(As per revised syllabus)

Published by	: Mrs. Meena Pandey for Himalaya Publishing House Pvt. Ltd. , "Ramdoot", Dr. Bhalerao Marg, Girgaon, Mumbai - 400 004. Phone: 022-23860170, 23863863; Fax: 022-23877178 E-mail: himpub@vsnl.com; Website: www.himpub.com
Branch Offices	:
New Delhi	: "Pooja Apartments", 4-B, Murari Lal Street, Ansari Road, Darya Ganj, New Delhi - 110 002. Phone: 011-23270392, 23278631; Fax: 011-23256286
Nagpur	: Kundanlal Chandak Industrial Estate, Ghat Road, Nagpur - 440 018. Phone: 0712-2721215, 3296733; Telefax: 0712-2721216
Bengaluru	: Plot No. 91-33, 2nd Main Road, Seshadripuram, Behind Nataraja Theatre, Bengaluru - 560 020. Phone: 080-41138821; Mobile: 09379847017, 09379847005
Hyderabad	: No. 3-4-184, Lingampally, Besides Raghavendra Swamy Matham, Kachiguda, Hyderabad - 500 027. Phone: 040-27560041, 27550139
Chennai	: New No. 48/2, Old No. 28/2, Ground Floor, Sarangapani Street, T. Nagar, Chennai - 600 012. Mobile: 09380460419
Pune	: "Laksha" Apartment, First Floor, No. 527, Mehunpura, Shaniwarpath (Near Prabhat Theatre), Pune - 411 030. Phone: 020-24496323, 24496333; Mobile: 09370579333
Lucknow	: House No. 731, Shekhupura Colony, Near B.D. Convent School, Aliganj, Lucknow - 226 022. Phone: 0522-4012353; Mobile: 09307501549
Ahmedabad	: 114, "SHAIL", 1st Floor, Opp. Madhu Sudan House, C.G. Road, Navrang Pura, Ahmedabad - 380 009. Phone: 079-26560126; Mobile: 09377088847
Ernakulam	: 39/176 (New No. 60/251), 1st Floor, Karikkamuri Road, Ernakulam, Kochi - 682 011. Phone: 0484-2378012, 2378016; Mobile: 09387122121
Bhubaneswar	: Plot No. 214/1342, Budheswari Colony, Behind Durga Mandap, Bhubaneswar - 751 006. Phone: 0674-2575129; Mobile: 09338746007
Kolkata	: 108/4, Beliaghata Main Road, Near ID Hospital, Opp. SBI Bank, Kolkata - 700 010. Phone: 033-32449649; Mobile: 07439040301
DTP by	: Rajani / Rakhi
Printed at	: Rose Fine Art, Mumbai. On behalf of HPH.

Preface

It is a matter of great pleasure to present this Revised edition of the book on *Cost Accounting - IV* to the students and professors of B.Com. (Accounting and Finance), Semester VI, University of Mumbai. This book is written on lines of syllabus instituted by the Mumbai University. The book presents the subject matter in a simple and convincing language.

We owe a great many thanks to a great many people who helped and supported us during the writing of this book which includes Principals, Professors and Students of M.Com. Section.

The syllabus contains a list of the topics covered in each chapter which will avoid the controversies regarding the exact scope of the syllabus. The text follows the termwise, chapter-topic pattern as prescribed in the syllabus. We have preferred to give the text of the section and rules as it is and thereafter added the comments with the intention of explaining the subject to the students in a simplified language. While making an attempt to explain in a simplified language, any mistake of interpretation might have crept in.

This book is an unique presentation of subject matter in an orderly manner. This is a student-friendly book and tutor at home. We hope the teaching faculty and the student community will find this book of great use. We welcome constructive suggestions for improvement.

We are extremely grateful to Shri K.N. Pandey of Himalaya Publishing House Pvt. Ltd. for their devoted and untiring personal attention accorded by them to this publication. We gratefully acknowledge and express our sincere thanks to the following people without whose inspiration and support, constructive suggestions of this book would not have been possible.

- *Mr. Jitendra Singh Thakur (Trustee, Thakur College)*
- *Dr. Chaitaly Chakraborty (Principal, Thakur College)*
- *Mrs. Janki Nishikant Jha*

Authors

Syllabus

Modules at a Glance

Sr. No.	Modules	No. of Lectures
1	Budgeting and Budgetary Control	15
2	Absorption Costing and Marginal Costing, Cost Volume and Profit Analysis	15
3	Managerial Decision Making	15
4	Standard Costing and Variance Analysis	15
Total		60

Module	Topics
1	<p>Budgeting and Budgetary Control</p> <p>Meaning and Objectives, Advantages and Limitations of Budgets Functional Budgets, Fixed and Flexible Budgets Zero Based Budgeting, Performance Budgeting <i>Practical problems of preparing flexible budgets and functional budgets</i></p>
2	<p>Absorption Costing and Marginal Costing, Cost Volume and Profit Analysis</p> <p>Absorption Costing and Marginal Costing Meaning of Absorption Costing Introduction to Marginal Costing Distinction between Absorption Costing and Marginal Costing Advantages and Limitations of Marginal Costing</p> <p>Cost Volume and Profit Analysis Break-even Analysis – Meaning and Graphic Presentation Margin of Safety Key Factor <i>Practical problems of preparing flexible budgets and functional budgets</i></p>
3	<p>Managerial Decision Making</p> <p>Make or Buy Sales Mix Decisions</p>

	<p>Exploring New Markets</p> <p>Plant Shut Down Decision</p> <p><i>Practical problems</i></p>
4	<p>Standard Costing and Variance Analysis</p> <p>Preliminaries in Installing of a Standard Cost System</p> <p>Material Cost Variance</p> <p>Labour Cost Variance</p> <p>Variable Overhead Variances</p> <p>Fixed Overhead Variances</p> <p>Sales Variances</p> <p>Profit variances</p> <p><i>Practical problems</i></p>

Paper Pattern

Credit Based Evaluation System

Scheme of Examination

(a) Semester End Examination

75 Marks

Q. No.	Particulars	Marks
Q.1	Objective Questions* (A) Sub-questions to be asked (10) and to be answered (any 8) (B) Sub-questions to be asked (10) and to be answered (any 7) (*Multiple Choice/True or False/Match the Columns/Fill in the Blanks)	15
Q.2	Full Length Practical Question OR	15
Q.2	Full Length Practical Question	15
Q.3	Full Length Practical Question OR	15
Q.3	Full Length Practical Question	15
Q.4	Full Length Practical Question OR	15
Q.4	Full Length Practical Question	15
Q.5	(A) Theory Questions (B) Theory Questions OR	8 7
Q.5	Short Notes To be asked (05), To be answered (03)	15

Note: Practical question of 15 Marks may be divided into two sub-questions of 7/8 and 10/5 Marks. If the topic demands, instead of practical questions, appropriate theory question may be asked.

(b) Internal of Assessment

25 Marks

- One Class Test (20 Marks)
 - Match the Column/Fill in the Blanks/Multiple Choice Questions ($\frac{1}{2}$ Mark each) 05 Marks
 - Answer in One or Two Lines (Concept-based Questions) (01 Mark each) 05 Marks
 - Answer in Brief (Attempt Any Two of the Three) (05 Marks each) 10 Marks
- Active participation in routine class instructional deliveries and overall conduct as a responsible learner, mannerism and articulation and exhibit of leadership qualities in organizing related academic activities. 05 Marks

Contents

1. Budgeting and Budgetary Control	1 – 53
2. Absorption Costing and Marginal Costing, Cost Volume and Profit Analysis	54 – 78
3. Managerial Decision Making	79 – 113
4. Standard Costing and Variance Analysis	114 – 167
University Problems and Solutions	168 – 224

BUDGETING AND BUDGETARY CONTROL

Introduction

Basically, management is the co-ordination of human effort, i.e., the accomplishment of goals by utilising the efforts of other people. Management is termed efficient if it accomplishes the objectives with minimum effort and costs. Management planning and control has been recognised as one of the most important approaches for facilitating effective performance of the management process.

While all business endeavours have multiple objectives of profit and contribution to the economic and social improvement, non-business endeavours have relatively precise objectives generally to be accomplished within specified cost constraints. Whether it is a business or non-business endeavour it is essential that the management and other interested parties are very well acquainted with the objectives and goals so that proper managerial guidance could be given and the effectiveness with which the desired activities are performed could be measured.

So, whatever be the endeavour, the management process essentially conforms to the general pattern – planning, co-ordination and control. With the increasing competition among profit making enterprises, the concept of profit planning and control system has gained wide acceptance which requires management to design its course in advance and use appropriate techniques to assure co-ordination and control of operations.

Elements of Management Planning and Control System

Management planning and control means the development and acceptance of objectives and goals and moving an organisation efficiently to achieve the desired objectives and goals. It is not a separate technique but entails an integration of all the functional and operational aspects of an enterprise.

Although management planning and control is related to accounting, it is a management system which comprises of activities of planning, co-ordination and control. For long-range success the stream of managerial decisions must generate plans and actions to provide the essential inflows that are necessary to support the planned outflows of the enterprise so that realistic profit and return on investment are earned. The relationship between these activities of the management can be seen in the Figure 1.1.

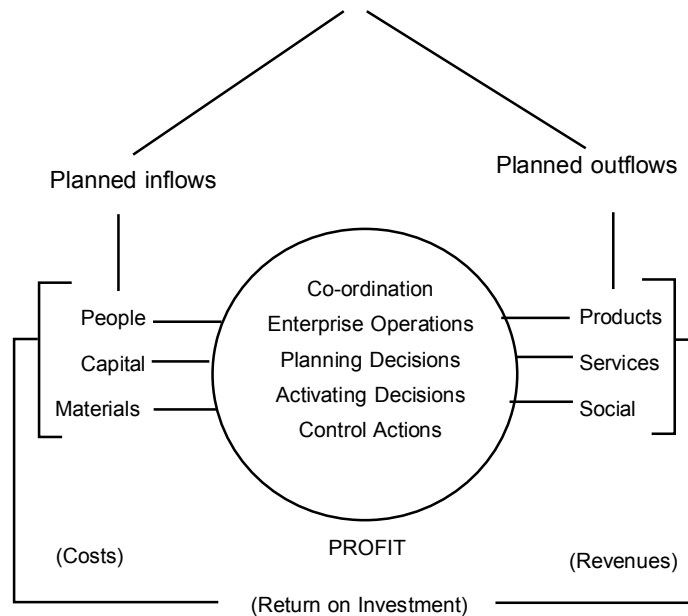

Figure 1.1: Planning and Controlling Inflows and Outflows for Profit

It may be noted that planned inflows are people, capital and materials, generally cost-incurring factors while outflows are products, services and social contributions that the enterprise generates which are generally revenue-generating factors. The responsibility of management is to manipulate, through the management process, i.e., planning, activating (or co-ordinating) and control the combinations of inflows and outflows so that the long-range objectives of the enterprise generally in terms of profit and return on investment are attained.

Planning

Planning has been defined as the design of a desired future state for an entity and rests on the belief that the future state can be attained by continuous management action. Thus, it projects the effective ways of attaining this desired future state, and presupposes that an entity can be more successful, in terms of its broad objectives, because of planned management decisions than it can if there were no planned intervention by the management.

The purpose of planning is to provide the managers with the guidelines for making decisions on a day-to-day basis. Planning referred here, is a decision-making process of highest order and thus requires management time and dedication. It starts with an attempt to project the future state without any intervention by the management and the desired state of the entity. Then, it concludes with a planning projection and thus, projects the ways to attain the desired future state realistically.

Planning is a continuous process since it requires constant revisions with changing conditions.

Control

Control may be defined simply as the action necessary to assure that objectives, plan, policies and strategies are being attained. It rests upon a firm foundation of management planning and thus, believes that the objectives, plans, policies and strategies are properly planned and communicated to those managers who are responsible for their accomplishment.

Generally, a control process encompasses the following:

1. Measuring performance against predetermined objectives and standards.
2. Communicating to the appropriate managers of the results.
3. Calculating deviations from the set objectives and standards.
4. Framing all possible alternative ways to correct the indicated variances.
5. Choosing and implementating the most promising alternative.
6. Appraising the corrective action and improve future planning and control cycles.

Control is effective if it is exercised at the point of action or at the time of commitment rather than after the completion of the action. This implies that the objectives, plans, policies and standards are communicated to and understood by the managers who are responsible for certain actions, so that they would be in a position to exercise control at the point of action.

In control process, evaluation of an actual result must be based upon some standard of performance. Current actual results can be compared to the actual results of the prior period. In this way, trends are revealed. However, comparison with prior period actual results may not provide effective measurement of performance due to the following reasons – (1) conditions may have changed (2) accounting classifications adopted may be different, and (3) performance in the prior period itself would have been unsatisfactory. Thus, the management has to evaluate the performance of various managers after taking into consideration the above points.

Co-ordination

Though Co-ordination is listed as a separate function of management, it should be viewed as an effect that ensues when the managerial functions of planning and controlling are accomplished.

Co-ordination is the synchronisation of individual actions with the result that each subdivision of an entity effectively works toward the common objectives. Co-ordination is regarded as one of the central tasks of management as it involves a reconciliation of differences in effort, timing, policies and aggregation of resources. Lack of co-ordination in an enterprise is observed when a department head is permitted to expand the department on the specific needs of that department only, although such expansion may negatively affect other departments and alter their performances. Thus, co-ordination is required at all vertical levels and on a horizontal basis.

The process of management planning and control system is summarised in the Figure 1.2.

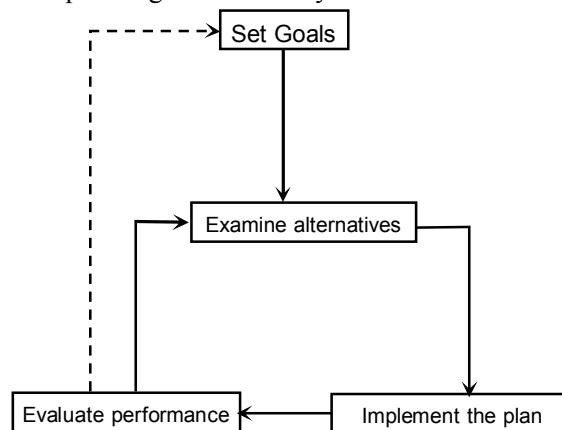

Figure 1.2

Role of Accounting Information

As already said, management planning and control system is related to accounting system. Let us see how this information enters into planning and control process.

Suitable goals are set based on the information provided by the accountants. Projections of future sales, expenses, incomes [and estimation of profits are made] depending on the accounting information.

After setting goals while examining alternatives, information about these alternatives comes from accounting system and the accountant is made to combine the data and produce meaningful reports.

Though, implementation of chosen alternative is done by the managers alone without the intervention of accounting system, the accountant is required to collect and summarise data about the success of the chosen plan. The evaluation of performance depends heavily on the facts that the accountant accumulates and reports.

The flowchart in Figure 1.3 summarises the planning-control cycle and the part played by the accountants and other information providers.

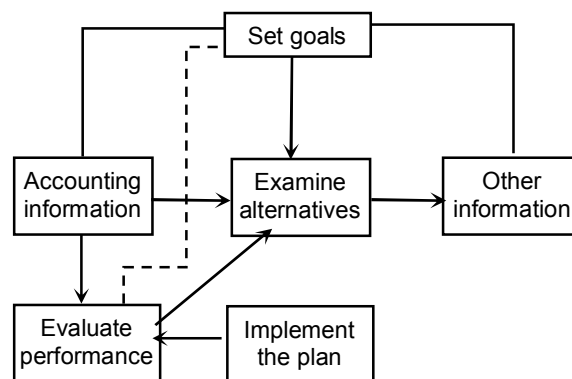

Figure 1.3

Though, accounting system is helpful in the process of planning and control it should be emphasised that the accountant does not necessarily participate in the management, and that his information may not necessarily prove that the success or failure has been achieved or suffered.

Budgeting as a Tool of Management Planning and Control

Budget is a numeric representation of the manager's plans for a specified period of time. It is commonly used by business firms, governmental agencies, non-profit organisations and even households. While there is considerable variation in the scope, degree of formality and level of sophistication applied to budgeting, most of the well managed business firms use budget which is a comprehensive and co-ordinated plan for the operations and resources of the firm.

A Budget can serve as an extremely useful tool for all managers.

- (i) **Communication:** A budget can serve as a means of communicating information within a firm. It is especially useful to lower level managers. For example, the district sales managers can know from the budget the level of sales that are expected of them or the production manager can know through the budget how much he can spend towards labour

expenses, etc. The budget serves as a communicator over time. As everyone tends to forget what they have planned without a written record, budget will remind them of their goals and progress towards the goals.

- (ii) **Co-ordination:** Whenever a manager is faced with managing two or more interrelated processes, he encounters the need to co-ordinate operations to maximise the utilisation of the available resources and to minimise idleness. A manager of a small manufacturing concern needs to co-ordinate such things as raw material purchases, working capital matter, labour union negotiations, etc. As the size of the operations increases, the number of factors to be co-ordinated increase and the manager is likely to find himself in a precarious situation without a concretely stated central plan. Co-ordination is essential when responsibility for different segments is delegated to separate individuals. The budget can serve for the above purpose of co-ordination.
- (iii) **Measurement of Success:** Success is determined by comparing past performance against a previous period's performance. However, this comparison using historical records does not take into consideration the changes that take place for example, the market for the product may have increased, etc. Whereas, budgets provides us to compare the actual performance with the budgeted performance which is an estimate of 'what might have been' taking all the possible changes into account. Though budget is only a prior estimate of future conditions and thus subject to manipulation, it can be used as a success criterion, if done carefully and with additional data.
- (iv) **Motivation:** Budgets prepared for the coming year motivates the managers to do their best. And, if a reward system is attached to the budget it further motivates the managers to achieve the levels of output.

Application of the Budget

In the following areas, budgeting can be applied.

Outputs

Careful analysis of future sales will be made. Then the manager will begin to plan production or purchase requirements to meet the expected sales figure. With the budgets prepared he would be in a position to utilise the available resources efficiently to meet the anticipated demand.

Inputs

Once the Budget establishes a manufacturing firm's output requirements, the manager can go about planning for labour and materials acquisition to support the desired output levels. Budgets help the managers to plan in advance for future and negotiate labour and material contracts at favourable rates. Without budget he may be forced into emergency purchases at higher costs, less skilled or overtime skilled labour and sometimes he may have to face with no production situation because of shortage of input. Budget helps managers to avoid off season layoffs and peak period bulges by spreading production more evenly through the year.

Facilities

Good budgeting also informs the manager about the adequacy of existing facilities for his future needs. However, this approach will require additional storage of materials and finished products and hence more space. Increased inventory costs leads to increased non-cash working capital and hence

cash may be borrowed until sales can be made. Thus, budgeting facilitates the above anticipations and assists in establishing co-ordination. Production of some materials needs special equipment, the need of which can be anticipated by budgeting and can be procured at favourable terms instead of a rush rental.

Administration

Budgeting applies equally well to administrative activities. Needs for clerks, storekeepers, book-keepers, secretaries, office supplies, etc., can be handled in the similar fashion through foresight and planning. Anticipation can lead to efficiency and higher profits in the office as well as in the production.

Cash Needs

Budgeting provides estimation of future receipts and disbursements. Careful planning facilitates the treasurer to minimise the chances of running out of cash and go bankrupt and also avoids situations of excess cash which is not capable of earning income.

Control

A well-structured budget can lead to efficient control of the firm as the manager has an indication of what should be done and can more easily spot what is being ineffectively done.

Organisation of the Budget

The following guidelines may be followed in preparing a budget.

Assigning personnel: The manager of an entity should assign his most qualified personnel to the preparation of the budget. The organisation chart that is generally found in medium sized firms is shown in Figure 1.4.

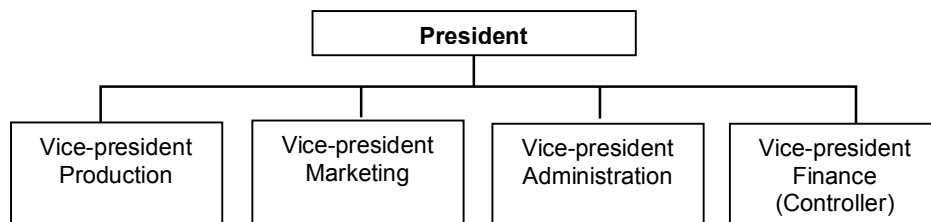

Figure 1.4

The four vice-presidents have responsibility for their respective functional areas. Each will delegate authority to his subordinates in order to get work done. Though, the Vice-president for finance provides information required by other departments, he makes decisions concerning the operation of his own department only.

A better course of action is to establish a budget committee with representation from each of the financial areas. A Budget Committee usually reports directly to top management. In large companies the budget committee is composed of executives in-charge of major functions of the business and includes the sales manager, personnel manager, finance manager, the production manager, the chief engineer, the treasurer and the chief accounts officer. One member of the budget committee is the budget director who is in-charge of preparing a budget manual of instructions and accumulating the

proposed budget data. In large companies, the position may be full-time job; in smaller companies, the post may be assigned to the finance manager or chief accounts officer or some other officer who acts as budget director on a part-time basis.

The principal functions of the budget committee are to:

- Decide the company's general policies and objectives;
- Receive and review individual budget estimates concerning different departments/units/division;
- Suggest changes, modifications in accordance with organisational objectives;
- Approve budgets which act as an authority/target for departmental action;
- Receive and analyse performance reports regarding the implementation of budgets;
- Suggest corrective action to improve efficiency and achieve budgetary goals.

Deriving Budget Figures

There are three ways that the budget committee can derive the estimates that appear in the final budget.

In one approach, known as imposed budget or top-down approach, the budgeted quantities are obtained from the top level managers and then communicated downward to the lower level managers. Low level managers do not participate in this type of budget, i.e., they have nothing to say about what is expected of them.

One important advantage of this type of budgeting is that the top level managers are involved in planning decisions and as such they have wider perspective of the firm's operation and would be in a position to allocate various resources among the various areas of responsibility.

Additionally, this is very cheaper because of the relatively fewer persons involved. However, this approach has two disadvantages. Firstly, top level managers, due to their positions, are separated from actual production and marketing processes and their allocation of resources to various areas would be without specific knowledge and as such may not be proper. Secondly, as the low level managers do not participate in preparing the budget, they are not motivated to work as per the estimates.

Another approach, known as participative approach is designed to eliminate the above disadvantages of imposed budgeting. In participating approach, estimations of lower level managers are coordinated and communicated upward to the top level managers. As lower level managers are given special importance in the preparation of budget figures, they will make special efforts to meet those goals. Participating approach rests on the belief that the low level managers who involve in day-to-day activities know very well his requirements and abilities and as such can give proper budgeted figures.

However, this approach too has disadvantages. Firstly, the manager may inflate the importance of his own area of responsibility and produce unrealistic demands. Secondly, to be in a comfortable position, each manager may provide for more inputs than required. And, from practical point of view, this approach is costlier to imposed approach.

Keeping in view the disadvantages of both the approaches, very few firms follow either a pure imposed or a pure participating approach. Thus, generally what is followed is the mixed approach, known as negotiated approach in which the possible goals set by higher level managers are

communicated downward to lower level managers for their acceptance. If the lower levels are not satisfied with the set goals they are allowed to suggest alternatives, either in terms of expectations or resources. Then, the upper management makes the necessary alternation. It is believed that this approach brings out the advantage of the other two, i.e., it combines a broad perspective of top management with precise knowledge of line managers. It also achieves a personal commitment from the lower levels to reasonable goals. Of course, all these advantages are obtained at a cost of high managerial expenses.

Selecting the Time Frame

The time/budget period is an important factor in developing a comprehensive budgeting programme. This is the period for which forecasts can reasonably be made and budgets can be formulated. A business enterprise generally prepares a Short-range budget and a Long-range budget.

Short-range Budget

Short-range budgets may cover periods of three, six or twelve months depending upon the nature of the business. Most manufacturing firms use one year as the planning period. Wholesale and retail firms usually employ a six-month budget which is related to their selling seasons. In determining the period of the Short-range budget, the following factors should be considered.

The budget period should be long enough to cover complete production of various products.

For business of a seasonal nature, the budget period should cover at least one entire seasonal cycle.

The budget period should be long enough to allow for the financing of production well in advance of actual needs. It should provide adequate time to arrange the funds for production and other purposes.

The budget period should coincide with the financial accounting period to compare actual results with the budget estimates and thus to facilitate better interpretation of the performance.

Long-range Budget

A Long-range budget or planning is defined as “a systematic and formalised process for purposefully directing and controlling future operations toward a desired objective for periods extending beyond one year.” Long-range budgets cover specific areas, such as future sales, future production, long-term capital expenditures, extensive research and development programmes, financial requirements, profit/forecast. They evaluate the future implications associated with present decisions and help management in making present decisions and select the most profitable alternative. Long-range budgeting does not eliminate risk altogether, it only reduces the risk to a level which does not hamper the production and achievement of company objectives.

There are many factors which are duly considered while preparing long-term budgets, such as market trends, economic factors, growth of population, consumption pattern, industrial production, national income, government economic and industrial policy. Quantitative sales can be budgeted for a three to five years period. After forecasting sales, a budgeted profit and loss account can be prepared relating anticipated sales to corresponding cost and thus net operating profit can be forecasted. Likewise, a balance sheet for many years can be prepared to forecast cash, inventory levels, accounts receivable, accounts payable, liabilities, etc. The forecasted profit and loss account and balance sheet for a Long-range is a very useful tool in accomplishing the objectives of the organisation as a whole.

Limiting or Principal Budget Factor

When budgets are made, there is invariably some factor which governs or sets a limit to the quantity which can be made or sold. This is known as the limiting or principal budget factor. A principal budget factor is “the factor the extent of whose influence must first be assessed in order to ensure that the functional budgets are reasonably capable of fulfilment.” In the field of sales the limiting factor is customer demand which is influenced by many factors, such as price and quality of the product, competition, the general purchasing power of the public, advertising, etc. In the field of production, the principal budget factor may be plant capacity, the supply of labour of the right quality or the availability of scarce materials. Sometimes, management itself may impose limiting factors, e.g., management may control production to maintain a definite price level or management may not decide to purchase plant and machinery and thus to maintain the same plant capacity.

The limiting or principal budget factors must be carefully considered while preparing the budget. If not properly taken into account, budgets may not be realistic and become difficult to achieve. Co-ordination among different departments will be lacking. The principal budget factors can be eliminated by taking suitable measures, for example, the plant capacity can be increased by purchase of additional plant.

The Budgeting Process

Budgeting Sales

Every activity of a profit oriented firm must be directed to one overall goal – sales because if the products cannot be sold at a profit, there would not be any economic reason for the firm to produce them. And also, sales is regarded as the primary source of cash. The capital-additions needed, the production level, manpower requirements and other important operational aspects depend on the volume of sales.

Thus, the sales plan is the foundation for periodic planning in the firm, because practically all other enterprise planning is built on it. The usefulness of the entire budget depends on the reliability of the sales estimates. If sales estimate is too low, profits will be lost because the firm will not be able to provide all the units, the customers demand. And, if the sales estimate is too high, the firm has to incur more costs than it can recover by sales. Hence, a great deal of effort should be expended on the preparation of the forecast of sales.

Much of the expertise for the preparation of sales forecast is generally found within the marketing staff of the firm. This group will gather information from many sources and marketing studies are done to determine whether the market for the product still exists or not and if it does how large it will be. Various possibilities such as price changes, etc., are evaluated and various strategies are framed. The Budget Committee will accept the best one among the various alternatives and the planning phase begins. An important factor considered in the planning of the sales volume is price at which the product can be sold.

Pricing Decision

Three important factors that affect pricing decision are demand for the product, cost recovery and profit margins.

Demand

Before deciding the price of the product a firm has to check whether market already exists for that product or whether it is a new product in the market. If it is already an existing product in the market, it can charge a higher price for the product only when it can create products with superior quality. Or else, it should check whether it is profitable for it to sell at the existing price or at a lower one. If, on the other hand, the product is a new one, though it has freedom in selecting the price level in the beginning it should build flexibility into the pricing system so that it can respond quickly to any strategy that may be employed by others later.

Another approach is first to determine the price in order to attract the customers and then to design the product in such a way that it can be manufactured at a cost sufficiently low to assure a profit.

Cost Recovery

Law of economics holds that if a firm has to survive, its total sales revenue should exceed its total costs. The firm should determine the price level, at which sales revenue exceeds the total costs, which includes not only the production costs but also selling and administration costs. Thus, the firm can adopt cost-plus strategy, i.e., to determine the selling price by adding profit margin to the average unit cost. This approach should be made by careful market research as it completely neglects the competition. It assumes that the competitors will essentially have the same cost and same profit margin as the firm has.

Profit Margins

The third major point to be considered in establishing prices concerns the amount of profit that management would like to achieve in the upcoming time period. Generally, the goal of the management is to obtain satisfactory profits. Usually, businessmen employ two measures in gauging the size of the profits. They are return on sales and return on investment. Return on sales represents the portion of each sales dollar that eventually ends up as a profit and return on investment is the ratio between net profits and the assets used to produce those profits. Whatever is the measure employed, the firms should determine the rate of return required and establish the desired amount of profit and then select the pricing policy.

Sales Budget

After determining the price at which the product is to be sold, it should decide the volume of units that it can sell. It cannot establish a high sales volume as the firm may not be able to capture the market to sell that many units. Then, the sales budget is prepared which is the numeric representation of the marketing department plans for the coming year.

Table 1.1 presents a specimen of a sales budget.

**Table 1.1: ABC Company Ltd.
Sales Budget for the year ending December 31, 2020**

Products	Budgeted Sales Units	Budgeted Sales Price	Total
A	70,000	55	38,50,000
B	80,000	40	32,00,000
	1,50,000		70,50,000

Budgeting Production

Once the sales forecast is established, it is the task of the budget committee to prepare plans for making the product available for sale. The requirements of the sales plan must be translated into the supporting activities of the other major functions. In the case of a service company, the sales plan must be converted to service capability requirements; for a retail or wholesale enterprise, the sales plan must be translated into merchandise purchases requirements; and in the case of a manufacturing enterprise, the sales plan must be converted to production (manufacturing) requirements.

Outputs

As the sales forecast deals with the number of units to be sold, production budget deals with the products that are to be produced/manufactured. In rare cases production output equals sales. It is highly possible that some of the items sold comes from the inventory held or some of the units products add up to the inventory held. So, production management should not only co-ordinate with sales management but also with inventory management.

The general equation which deals with flow of goods is:

Beginning inventory + Production – Sales = Ending inventory.

This can also be expressed as:

Production = Sales + Change in Inventory.

Where change in inventory is equal to

Ending Inventory – Beginning Inventory.

Thus, if there is no change in inventory then cost of production will be equal to cost of goods to be sold. But, if the management feels that the future sales will be growing it will seek to utilise as much production capacity as possible in case of inflation in order to produce at the lowest cost possible and to earn revenues later. In this case, as the inventories have to be increased in anticipation of being sold at higher prices, production must also be increased. On contrast, if a decline in future demand is expected, it is appropriate to reduce the inventory in order to avoid holding losses from decline in prices and thus production has to be below sales volume.

Table 1.2 exhibits a specimen of production budget.

**Table 1.2: ABC Company Ltd.
Production Budget for the year ended December 31, 2020**

	Products	
	A	B
Budgeted Sales (in units)	70,000	80,000
<i>Add:</i> Desired closing finished goods inventory	20,000	30,000
	90,000	1,10,000
<i>Less:</i> Beginning finished goods inventory	40,000	20,000
Budgeted production requirement	50,000	90,000

The Schedule presented above is the overall production budget for ABC Company Ltd. The publication of the production budget accomplishes the co-ordination of the efforts of the production

and sales divisions. The latter group knows what it has to sell and the former knows what it has to produce.

Inputs

The production budget forms the basis for direct labour budgets, material budgets and manufacturing overheads budgets. Figure 1.5 presents graphically the flow of the planning activity from sales through the manufacturing executive's plan.

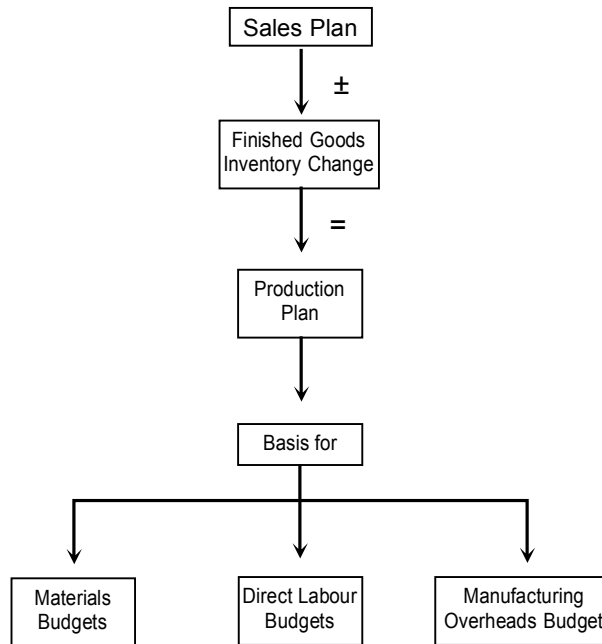

Figure 1.5

Thus, after co-ordinating plans for output, the next step for the production manager is to anticipate the acquisition of direct labour, direct material and manufacturing overhead expenses.

Direct labour costs consists of wages paid to employees who are engaged directly in specific productive output. Thus, direct labour budget represents the direct labour requirements necessary to produce the types and quantities of outputs planned in the production budget.

In planning for direct labour, the manager needs to examine such areas: manpower needs, recruitment, training, job evaluation and specification, performance evaluation, union negotiations and wage contracts.

The manager should identify his needs for skilled labour and see whether he can provide for them from the existing payroll or whether he can train some of his employees. He has to determine the price per labour hour. He must also carefully consider the requirements of union contracts before preparing a labour budget.

Table 1.3 illustrates the preparation of a direct labour budget.

**Table 1.3: ABC Company Ltd.
Direct Labour budget for the year ended December 31, 2020**

	Products		Total
	A	B	
Budgeted Production			
Direct labour	50,000	90,000	
Hours/Units	3	2	
Total direct labour	1,50,000	1,80,000	3,30,000
Hours			
Direct labour	₹ 5	₹ 5	₹ 5
Cost/hour			
Total direct labour cost	7,50,000	9,00,000	16,50,000

Labourers cannot produce a product unless they have materials and production planning requires anticipating the need for materials.

A direct materials budget indicates the expected amount of direct materials required to produce the budgeted units of finished good. This budget specifies the cost of direct materials used and the cost of the direct materials purchased. Table 1.4 explains the calculation of the direct materials budget. The usage part of the direct materials budget determines the cost of purchases of direct materials.

Table 1.4: ABC Company Direct Materials Budget for the Year Ending December 2020

	Products		Total
	A	B	
A. Usage Budget			
Budgeted product in units	50,000	90,000	
Direct materials requirement			
Product A: 5 kg per unit	× 5		
Product B: 8 kg per unit		× 8	
Direct materials usage (kg)	2,50,000	7,20,000	
Cost per kg (₹)	1.00	1.50	
Cost of direct materials	2,50,000	10,80,000	13,30,000
B. Purchase Budget	Direct materials (In kg)		
Direct material usage	2,50,000	7,20,000	
Add: Budgeted closing direct materials Inventory	50,000	75,000	
Total Requirements	3,00,000	7,95,000	
Less: Beginning direct materials inventory	70,000	1,00,000	
Purchase of direct materials	2,30,000	6,95,000	
Cost per kg	₹ 1.00	₹ 1.50	
Cost of purchase	₹ 2,30,000	₹ 10,42,500	

The direct materials budget is useful in the following ways:

- It helps the purchasing department to prepare a schedule to ensure delivery of materials when needed.
- It helps in fixing minimum and maximum levels of inventories in the stores department.
- It helps the finance manager to determine the financial requirements to meet production targets.

The materials budget usually deals with direct materials only. Supplies and indirect materials are generally included in the factory overhead budget.

In addition to direct labour and materials budget, the production manager may need to plan for other manufacturing overhead items like indirect labour, supplies, repairs, power and other factory overheads.

The factory overhead budget estimates the requirements and costs of the above overheads for the production of the budgeted units. It requires that expenses should be classified by departments since expenses are incurred by various departments. In this way departmental heads should be held accountable for expenses incurred by their departments. Generally, the department heads prepare budgets for their respective departments for the budget period. However, they need considerable help and advice from the budget director in order to achieve production budget.

Table 1.5 depicts the factory overhead budget wherein overhead costs have been classified into fixed and variable components.

Table 1.5: ABC Company
Factory Overhead Budget for the Year Ending December 2020
(based on budgeted capacity of 3,30,000 direct labour hours)

Items	Direct Labour hours	Rate per direct labour hour (₹)	Total Cost
A. Variable factory overheads			
Supplies	3,30,000	0.70	2,31,000
Repairs	3,30,000	0.30	99,000
Indirect Labour	3,30,000	0.70	2,31,000
Others	3,30,000	0.25	82,500
Total variable factory Overheads cost			6,43,500
B. Fixed Factory			
Overheads cost			
Supervision		3,00,000	
Depreciation		3,50,000	
Property tax		1,50,000	
Others		2,06,500	
Total fixed factory Overheads cost			10,06,500
Total factory Overheads cost			16,50,000
pre-determined overhead rate			
= $\frac{₹16,50,000}{3,30,000 \text{ hours}}$			
= ₹ 5 per direct			

Budgeting Closing Inventories

An inventory budget can be prepared to find out the values of direct materials and finished goods inventory as shown in Table 1.6

**Table 1.6: ABC Company
Ending Inventory Budget for the Year Ending December, 2020**

	₹
Direct materials inventory	50,000
Product A 50,000 kg × ₹ 1.00 per kg	1,12,500
Product B 75,000 kg × ₹1.50 per kg	1,62,500
Finished goods inventory	7,00,000
Product A 20,000 units × ₹ 35.00	9,60,000
Product B 30,000 units × ₹ 32.00	16,60,000

* Manufacturing cost per finished unit (calculated in Table.1.7)

Table 1.7

	Product A			Product B		
	Quantity Required Kgs/hrs	Unit cost ₹	Product Unit Cost ₹	Quantity Required Kgs/hrs	Unit cost ₹	Product Unit Cost ₹
Direct material	5	1.00	₹ 5.00	8	1.5	₹ 12.00
Direct labour	3	5.00	₹ 15.00	2	5	₹ 10.00
Factory overheads	3	5.00	₹ 15.00	2	5	₹ 10.00
Total manufacturing cost						
Cost per finished unit			₹ 35.00			₹ 32.00

Budgeting Cost of Goods Sold

After preparing direct materials, direct labour, factory overhead, and ending inventory budgets, the cost of goods sold budget can be prepared. The cost of goods sold budget summarises all the above budgets as shown in Table 1.8.

**Table 1.8: ABC Company
Cost of Goods Sold Budget for the Year Ending December 31, 2020**

Direct materials	2,20,000	
Beginning inventory (70,000 × 1.00 + 1,00,000 × 1.50)	12,72,500	
Purchases (Table 1.4 B)	14,92,500	
Less: Closing inventory	1,62,500	13,30,000
Cost of direct materials used (Table 1.4 A)		16,50,000
Direct labour (Table 1.3)		16,50,000
Factory overheads (Table 1.5)		46,30,000
Total factory cost		

<i>Add:</i> Beginning finished goods inventory (40,000 × 35 + 20,000 × 32)		20,40,000
Total goods available for sale		66,70,000
<i>Less:</i> Finished goods inventory (Table 1.6)		16,60,000
Cost of goods sold		50,10,000

Budgeting Administration

The administrative expense budget covers the administrative costs for non-manufacturing business activities. Budgeting administrative expense is often difficult. Perhaps the first difficulty is in classifying certain costs as production or administrative. For example, costs like purchasing, engineering, personnel, research and development can be administrative as well as production. Unless such and other expenses are properly classified, their proper budgeting and subsequent control cannot be exercised. The second difficulty is in determining the persons responsible for the incurrence and control of these costs.

However, in order to accomplish the purpose of cost control in cost accounting, it is necessary that each item of cost should be under the jurisdiction and control of a responsible person who is accountable for incurring the cost. Table 1.9 presents an administrative expense budget.

**Table 1.9: ABC Company
Administrative Expenses Budget for the year ending December 31, 2020**

Items	Amount (₹)	Amount (₹)
A. Variable administrative expenses:		
(i) Supplies	30,000	
(ii) Clerical wages	65,000	
Total variable administrative expenses		95,000
B. Fixed Administrative Expenses:		
(i) Directors' remuneration	3,00,000	
(ii) Legal charges	20,000	
(iii) Depreciation	2,50,000	
(iv) Salaries	43,000	
(v) Rent	60,000	
(vi) Postage, telephone, etc.	32,000	
Total fixed administrative expenses		7,05,000
Total administrative expenses		8,00,000

Budgeting Selling Expenses

Closely related to the sales budget is the selling and distribution cost budget which shows the budgeted costs of promoting sales for the budget period. It is also known as the marketing expense budget. A selling expense budget consists mainly of the following major items:

- Sales representatives (salaries, commissions, entertaining and travelling).
- Sales office (office supplies, salaries, postage, telephone, rent and rates).
- Publicity office (salaries, office costs, press, journals, television, cinema, samples, sundries).
- Warehousing, packing and dispatch (salaries, packing wages, drivers wages, vehicle, costs, sundries).

Table 1.10 exhibits an annual selling expense budget classified according to fixed and variable expenses. The annual budget should be broken down on a monthly basis so that actual expenses can be compared with the budget monthly. Also, separate budgets for each of these expenses may be prepared especially in the case of a large company.

**Table 1.10: ABC Company
Selling Expenses Budget for the year ending December 31, 2020**

Items	Amount (₹)	Amount (₹)
A. Variable Selling Expenses:		
(i) Sales commission	1,00,000	
(ii) Salary and wages	60,000	
(iii) Advertising	30,000	
(iv) Travelling	60,000	
Total variable selling expenses		2,50,000
B. Fixed Selling Expenses:		
(i) Warehousing	1,00,000	
(ii) Advertising	75,000	
(iii) Marketing Managers' salary	1,25,000	
(iv) Depreciation	50,000	
Total fixed selling expenses		3,50,000
Total selling expenses		6,00,000

Budgeting Cash

The next step in the budgeting process is to prepare cash budget. Managers must be concerned with the amount of cash that flows in and out of the firm, as well as the amount that happens to be on hand at any particular time. If the firm has less cash than enough to keep the creditors satisfied it may have to face a suit filed by the creditors. On the other hand, if the firm has excess cash on hand, the firm would earn no income on it. So, the cash manager must have neither too little nor too much.

The first step, then, in preparing cash budget is to establish the desired amount to have on hand, i.e., which will be enough to meet any emergencies. The second step requires the manager to identify all the sources from which cash flows into the firm, like revenues from sales, borrowings, etc. He must also estimate the timing of the cash inflow. The third step is to identify the applications or uses of cash, such as payment for purchases, utility bills, salaries, etc. Even here he has to estimate the timing of the flow. Finally, these predictions are brought together in the cash budget, and the results are analysed. If there will be excess funds on hand, then plans should be made to find profitable temporary investments to occupy them and if shortages are predicted the manager should plan for short-term loans.

Table 1.11 presents a typical cash budget.

Table 1.11: ABC Company Cash Budget for the year ended

	Amount (₹)	Amount (₹)
Beginning cash balance		2,00,000
<i>Add: Receipts:</i>		
Cash Sales (50% of current year's sales)	35,25,000	
Receivables Collections (50% of previous year's sales)	32,50,000	
Investment income	0	67,75,000
Total cash available for use		69,75,000
<i>Less: Expenditures:</i>		
Cash Purchases	12,72,500	
Labour and Factory Overheads	33,00,000	
Administrative and Selling Expenses	14,00,000	
Total cash to be used		59,72,500
Net cash available		10,02,500

Budgeted Financial Statements

After plans have been made for the firm's cash, revenues, costs and asset acquisitions, it is possible to prepare budgeted financial statements. These statements will be identical to ordinary ones except that they will show the expected results of the operations for the forthcoming year and expected financial position as on that particular future date.

Tables 1.12 and 1.13 shows the Budgeted Income Statement of ABC Co. Ltd. and a typical balance sheet respectively. These statements along with cash budget represents the Master Budget which is presented to the board of directors by the budget committee.

**Table 1.12: ABC Company Ltd.
Budgeted Income Statement for the year ended December 31, 2020**

	Amount (₹)	Amount (₹)
Sales (Table 1.1)		70,50,000
Cost of goods sold (Table 1.8)		52,10,000
Gross Margins		18,40,000
Selling Expenses (Table 1.10)	6,00,000	
Administrative Expenses (Table 1.9)	8,00,000	14,00,000
Income before taxes		4,40,000
Income taxes (assuming 40%)		1,76,000
Net income		2,64,000

**Table 1.13: ABC Company Ltd.
Budgeted Balance Sheet as on December 31, 2020**

Capital and Liabilities		Amount (₹)	Assets		Amount (₹)
Equity Capital		60,00,000	Fixed Assets:	25,00,000	
Reserves and Surplus	7,00,000		Less: Depreciation @ 26% Investments	6,50,000	18,50,000
<i>Add:</i> Budgeted Net Income	2,64,000	9,64,000			
Long-term Loans		10,00,000	Current Assets:		
Current liabilities:			Cash		10,02,500
Sundry Creditors		60,000	Sundry debtors		35,25,000
Accrued Expenses:			Closing Inventories (1,62,500 + 16,60,000)		18,22,500
Income-tax payable		1,76,000			
		82,00,000			82,00,000

Revision of Budgets

As stated earlier in the chapter, successful budgets should have adequate flexibility to meet changing business conditions. Since budgets are used for planning, operation, co-ordination and control, they should be revised if changes occur in the environment. Revision of budgets may be necessary due to the following factors some of which might have been considered earlier in the development of budgets:

- Errors committed in preparing the budgets which may subsequently be known.
- Emergence of unforeseen and unanticipated situations which may cause the budget to be revised.
- Changes in internal factors, e.g., production forecast, sales forecast, capacity utilisation, etc.
- Changes in external factors, e.g., market trends, nature of the economy, prices of inputs and resources, consumers' tastes and fashions.

Fixed and Flexible Budgeting

Fixed Budgeting

A fixed budget is the budget which is designed to remain unchanged irrespective of the level of activity actually attained. It is based on a single level of activity. A fixed budget performance report compares data from actual operations with the single level of activity reflected in the budget. It is based on the assumption that the company will work at some specified level of activity and that a stated production will be achieved. Fixed budgets do not change when production level changes.

However, in practice, fixed budgeting is rarely used. The main reason is that actual output is often significantly different from the budgeted control. The performance report may be misleading and will not contain very useful information. For example, if actual production is 12,000 units in place of

the budgeted 10,000 units the cost incurred cannot be compared with the budget which relates to different levels of activity. Since, in fixed budgeting, units are overlooked, a cost to cost comparison without considering the units may give misleading results.

Flexible Budgeting

A flexible budget is defined as “a budget which by recognising the difference between fixed, semi-fixed and variable costs, is designed to change in relation to the level of activity attained.”

A flexible budget is a budget that is prepared for a range, i.e., for more than one level of activity. It is a set of alternative budgets to different expected levels of activity. Thus, a flexible budget might be developed that would apply to a “relevant range” of production, say 8,000 to 12,000 units. Under this approach, if actual production slips to 9,000 units from a projected 10,000 units, the manager has a specific tool (i.e., the flexible budget) that can be used to determine budgeted cost at 9,000 units of output. The flexible budget provides a reliable basis for comparisons because it is automatically geared to changes in production activity.

Steps in Flexible Budgeting

The following steps (stages) are involved in developing a flexible budget:

- Deciding the range of activity to which the budget is to be prepared.
- Determining the cost behaviour patterns (fixed, variable, semi-variable) for each element of cost to be included in the budget.
- Selecting the activity levels (generally in terms of production) to prepare budgets at those levels.
- Preparing the budget at each activity level selected by associating the activity level with corresponding costs. The corresponding costs to be attached with each activity level are determined in terms of their behaviour, i.e., fixed, variable and semi-variable.

Zero-based budgeting: A budget is developed usually on the concept of incrementalism. In case of budgeting in organisations, past events are considered in the light of future probabilities. The influence of past is strong in the budget of an ongoing activity and many entries may ultimately become just last year's figures plus a fixed percentage over and above that value. Since previous year's figures are considered as base, any inaccuracies in those figures are carried forward year after year.

But in zero-based budgeting, this can be avoided. In case of ZBB, each manager is asked to prepare his own requirement of funds beginning from scratch, ignoring the past and he has to justify the requirements mentioned by him. Hence, the main idea behind ZBB is to challenge the existence of every budgetary unit and every budget period.

Illustrations

Illustration 1: Prepare the Sales Budget from the following data:

Product	January	February
X	1200 units	1800 units
Y	3600 units	5400 units

The sales area A and B account for 60% and 40% sale of product X and 30% and 70% sale of product Y respectively.

The selling price per unit of product X ₹ 24 and the selling price per unit of product Y ₹ 30 in both the sales areas. [M. Com. Modified]

Solution:

January Sales Budget

Product	Area	Units	₹	₹
X	A	720	24	17,280
	B	480	24	11,520
Total		1,200		28,800
Y	A	1,080	30	32,400
	B	2,520	30	75,600
Total		3,600		1,08,000

February Sales Budget

Product	Area	Units	₹	₹
X	A	1,080	24	25,920
	B	720	24	17,280
Total		1,800		43,200
Y	A	1,620	30	48,600
	B	3,780	30	1,13,400
Total		5,400		1,62,000

Total Sales Budget

Product	Area	Units	₹	₹
X	A	1,800	24	43,200
	B	1,200	24	28,800
Total		3,000		72,000
Y	A	2,700	30	81,000
	B	6,300	30	1,89,000
Total		9,000		2,70,000

Illustration 2: The following are the estimated sales of a company for eight months ending 30-11-2020:

Months	Estimated Sales (Units)
April 2020	12,000
May 2020	13,000
June 2020	9,000
July 2020	8,000
August 2020	10,000
September 2020	12,000
October 2020	14,000
November 2020	12,000

As a matter of policy, the company maintains the closing balance of finished goods and raw materials as follows:

Stock Items	Closing balance of a month
Finished goods	50% of the estimated sales for the next month
Raw Materials	Estimated consumption for the next month.
Each unit of production requires 2 kg. of raw material costing ₹ 5 per kg.	

Prepare Production Budget (in units) and Raw Material Purchase Budget (in units and cost) of the company for the half year ending 30th September, 2020.

[M.Com., M.Phil & T.Y.BAF Modified]

Solution:

**Production Budget (in units)
For the half year ending 30th Sept. 2020**

Month	Sales in Units	Closing Bal. 50% of Estimated Sales for Next Month	Opening Bal.	Production (2 + 3 - 4)
(1)	(2)	(3)	(4)	(5)
April	12,000	6,500	6,000	12,500
May	13,000	4,500	6,500	11,000
June	9,000	4,000	4,500	8,500
July	8,000	5,000	4,000	9,000
August	10,000	6,000	5,000	11,000
Sept.	12,000	7,000	6,000	13,000
	64,000			65,000

**Purchase Budget (in Cost and Units)
For the half year ending 30th Sept. 2020**

Month	Production in Units	Consumption kg. ₹ 2/- per Unit	Closing Balance	Opening Balance	Purchase in kg.	Rate ₹	Amount
April	12,500	25,000	22,000	25,000	22,000	5	1,10,000
May	11,000	22,000	17,000	22,000	17,000	5	85,000
June	8,500	17,000	18,000	17,000	18,000	5	90,000
July	9,000	18,000	22,000	18,000	22,000	5	1,10,000
August	11,000	22,000	26,000	22,000	26,000	5	1,30,000
Sept.	13,000	26,000	26,000	26,000	26,000	5	1,30,000
	65,000	1,30,000		1,30,000			6,55,000

Illustration 3: A manufacturing company submits the following figures for the first Quarter of 2020.

Sales/Month	Product in units	
	X	Y
January	25,000	30,000
February	20,000	25,000
March	30,000	35,000

Selling price per unit product X ₹10 product Y ₹ 20

Prepare a sales budget based, on the above data for the first Quarter of 2021 assuming,

- (a) Sales quantity increase of X by 20%, Y by 10%
 (b) Sales price increase of X : Nil, Y : 10%

[M.Com. Modified]

Solution:

NOTE: U = units, SP = selling price, A = Amount

**Sales Budget
Actuals for 2020**

	January			February			March			Total		
	U x SP= A			U x SP= A			U x SP= A			U x SP= A		
Product X	25,000	10	2,50,000	20,000	10	2,00,000	30,000	10	3,00,000	75,000	10	7,50,000
Product Y	30,000	20	6,00,000	25,000	20	5,00,000	35,000	20	7,00,000	90,000	20	18,00,000
	–	–	8,50,000	–	–	7,00,000	–	–	10,00,000	–	–	25,50,000

Budgeted for 2021

	January			February			March			Total		
	U x SP= A			U x SP= A			U x SP= A			U x SP= A		
Product X	30,000	10	3,00,000	24,000	10	2,40,000	36,000	10	3,60,000	90,000	10	9,00,000
Product Y	33,000	22	7,26,000	27,500	22	6,05,000	38,500	22	8,47,000	99,000	22	21,78,000
	–	–	10,26,000	–	–	8,45,000	–	–	12,07,000	–	–	30,78,000

Illustration 4: (Purchase Budget)

Solo products manufactures single product and has sales of ₹ 126 lacs. Profit is 20%. Materials required are A = 3 lbs of ₹ 6 per lb and B = 1.5 lbs of ₹ 4 per lb.

Labour charges are : Machine shop = ₹ 4 per hour
 Assembly shop = ₹ 3.20 per hour

Number of Employees : Machine shop = 600
 Assembly shop = 180

Details of materials, finished goods:

	Finished Good	Material A	Material B
Opening stock	20,000 units	54,000 lbs	33,000 lbs
Closing stock	25,000 units	30,000 lbs	66,000 lbs

Processing time: Machine shop = 7 hrs

(per unit of output) Assembly shop = 2 and half hrs

Factory works for 5 days of 8 hrs in a week in a normal 52 weeks a year.

Expected Holidays = 96 hrs }

Expected Leave = 80 hrs } in a year

Expected Absenteesm = 64 hrs }

Calculate:

1. Number of units to be sold.
2. Purchase budget
3. Capacity utilisation of machine and assembly shops

Solution:

Cost Sheet of.....

	₹ Per unit
Material cost:	
A: $3 \times 6 = 18$	
B: $1.5 \times 4 = 6$	24
Labour cost:	
Machine shop : $7 \text{ hrs} \times 4 = 28$	
Assembly shop : $2 \frac{1}{2} \text{ hrs} \times 3.20 = 8$	36
Total cost	60
Profit = 20% (i.e. profit on sales)	15
Sales price	75

Total sales = 126 lacs

Therefore quantity of sales = sales value/selling price per unit

= 126 lacs/75

= 1,68,000 units

Material Budget:

Total finished goods units to be produced:

= sales + closing stock – opening stock

Production = 1,68,000 + 25000 - 20,000

PRODUCTION = 1,73,000 UNITS

Materials required to produce:

A: $1,73,000 \times 3 \text{ Ibs} = 5,19,000 \text{ Ibs}$

B: $1,73,000 \times 1.5 \text{ Ibs} = 2,59,500 \text{ Ibs}$

Value

For A: $4,95,000 \text{ Ibs} \times 6 = ₹ 29,70,000$

For B: $2,92,500 \text{ Ibs} \times 4 = ₹ 11,70,000$

₹ 41,40,000

Capacity utilisation of machine and assembly shops:

Total hours in machine shops utilised for production

$$= 1,73,000 \times 7 \text{ hrs} = 12,11,000 \text{ hrs required}$$

Total hours in assembly shops utilised

$$= 1,73,000 \times 2 \frac{1}{2} \text{ hrs} = 4,32,500 \text{ hrs required}$$

Total hours available:

$$\text{Machine shop } 5 \text{ days} \times 8 \text{ hrs} \times 52 \text{ weeks} \times 600 \text{ employees} = 12,48,000 \text{ hrs}$$

$$\text{Assembly shop } 5 \text{ days} \times 8 \text{ hrs} \times 52 \text{ weeks} \times 180 \text{ employees} = 3,74,400 \text{ hrs}$$

Actual hours available:

$$\begin{aligned} \text{Machine shop} &= 12,48,000 \text{ hrs} - (*240 \times 600) \\ &= 12,48,000 \text{ hrs} - 1,44,000 = 11,04,000 \text{ hrs} \\ &\quad *96 + 80 + 64 = 240 \end{aligned}$$

$$\begin{aligned} \text{Assembly shop} &= 3,74,400 \text{ hrs} - (240 \times 180) \\ &= 3,74,400 \text{ hrs} - 43,200 = 3,31,200 \text{ hrs} \end{aligned}$$

Capacity utilisation = HOURS REQUIRED/Actual hours available or Total hours available \times 100

$$\begin{aligned} \text{Machine shop} &= 12,11,000/11,04,000 \times 100 \\ &= 109.69\% = 1.1 \text{ times} \\ &= 130.59\% = 1.31 \text{ times} \end{aligned}$$

Illustration 5: (Manpower Budget)

The direct labour requirements of three of the products manufactured in a factory, each involving more than one labour operation, are estimated as follows;

Direct labour hours per unit (in minutes)

Products

Operation	Product 1	Product 2	Product 3
1	18	42	30
2	-	12	24
3	9	6	-

The factory works 8 hrs a day, 6 days a week. The budget quarter is taken as 13 weeks and during a quarter lost hours due to leave and holiday and other causes are estimated to be 124 hrs.

The budget hourly rates for the workers manning the operation 1, 2 and 3 are ₹ 2.00, ₹ 2.50, ₹ 3.00 respectively. The budgeted sales of the product during the quarter are:

Product 1 9,000 units

Product 2 15,000 units

Product 3 12,000 units

There is a carry over of 5000 units of product 2 and 4000 units of product 3 and it is proposed to build up a stock at the end of the budget quarter as follows:

Product 1 1,000 units

Product 2 2,000 units

Prepare a manpower budget for the quarter showing for each operation (i) direct labour hours (ii) direct labour cost and (iii) the number of workers.

(CA Modified)

Solution:

Preparation of labour budget

Computation of units to be produced

	Product 1	Product 2	Product 3
Units to be sold	9,000	15,000	12,000
Add: closing stock	1,000	2,000	–
Less: opening stock	–	5,000	4,000
Production	10,000	12,000	8,000

Time required (Mts)

Operation	Product 1	Product 2	Product 3	Total
1	18	42	30	90
2	–	12	24	36
3	9	6	–	15

Total time required for production;

Operation 1:

For product 1 = $10,000 \times 18$ = 1,80,000 Mts

For product 2 = $12,000 \times 42$ = 5,04,000 Mts

For product 3 = $8,000 \times 30$ = 2,40,000 Mts
= 9,24,000 Mts

Operation 2:

For product 1 = $10,000 \times -$ = –

For product 2 = $12,000 \times 12$ = 1,44,000 Mts

For product 3 = $8,000 \times 24$ = 1,92,000 Mts
= 3,36,000 Mts

Operation 3:

For product 1 = $10,000 \times 9$ = 90,000 Mts

For product 2 = $12,000 \times 6$ = 72,000 Mts
= 1,62,000 Mts

Total number of hours available 624 hours

Hours lost in leave, holiday etc. 124 hours

500 hours

500 hrs \times 60 Mts per hour = 30,000 Mts

- (a) Therefore, number of labourers required for:
- For operation 1: = $9,24,000/30,000$ = 30.8 labourers = 31 labourers
 For operation 2: = $3,36,000/30,000$ = 11.2 labourers = 12 labourers
 For operation 3: = $1,62,000/30,000$ = 5.4 labourers = 6 labourers
- (b) Time Required:
 Time required 1,62,000 Mts
 Time available 30,000 Mts
- (i) Labourer hours required:
- Operation 1 = $9,24,000/60$ = 15,400 hrs
 Operation 2 = $3,36,000/60$ = 5,600 hrs
 Operation 3 = $1,62,000/60$ = 2,700 hrs
- (ii) Labour cost:
- Operation 1 = $9,24,000/60 \times 2$ = ₹ 30,800
 Operation 2 = $3,36,000/60 \times 2.50$ = ₹ 14,000
 Operation 3 = $1,62,000/60 \times 3$ = ₹ 8,100
 Total = ₹ 52,900

Illustration 6: (sales, production and materials purchase budget master budget)

A company manufactures product A and product B. During the year ending December, 2020, it is expected to sell 15,000 kgs of product A and 75,000 kgs of product B at ₹ 15 and ₹ 8 per kgs respectively. The direct material P, Q and R are mixed in the proportion of 3:5:2 in the manufactures of product A. MATERIAL Q and R are mixed in the proportion of 1:2 in the manufacture of product B. The actual and budgeted inventories for the year are given below:

		Opening stock Kgs.	Expected closing stock kgs	Anticipated cost per Kg. ₹
Material	P	4,500	3,000	6/-
	Q	3,000	6,000	5/-
	R	30,000	9,000	4/-
Product	A	3,000	1,500	-
	B	4,000	5,500	-

Prepare sales budget, production budget and material purchase budget, showing the expenditure for the material for the year ending 31-12-2020.

[IPCC Modified]

Solution:**Product A**

EXPECTED SALE 15000 kgs
 @ ₹ 15 per kg

PQR 3/10: 5/10: 2/10

P $13,500 \times 3/10 = 4,050$

Product B

75,000 kgs
 @ ₹ 8 per kg.

QR 1/3: 2/3

P - = -

Requirement

4,050

Q	$13,500 \times 5/10 = 6,750$	Q	$76,500 \times 1/3 = 25,500$	32,250
R	$13,500 \times 2/10 = \underline{2,700}$	R	$76,500 \times 2/3 = \underline{51,000}$	53,700
Production	13,500	Production	76,500	
Production budget = Sales + Closing Stock – Opening stock				
Sale	15,000		75,000	
ADD: closing stock	1,500		5,500	
Less: opening stock	3,000		4,000	
Production	13,500		76,500	

Material purchase budget = requirement for production = closing stock – opening stock

	P	Q	R	Total
Requirement	4,050	32,250	53,700	-
(+) closing stock	3,000	6,000	9,000	-
(-) opening stock	4,500	3,000	30,000	-
Purchase Quantity	2,550	35,250	32,700	-
×				
Cost per kg	₹ 6	₹ 5	₹ 4	-
Purchase budget (₹)	15,300	1,76,250	1,30,800	3,22,350

Illustration 7:

Maya Limited has made the following sales estimates for April, May and June of the year 2019 from which you are required to prepare sales budget by units and rupees for each of the three months for each sale area and in total.

Sales area	April	May	June
A	40%	30%	30%
B	45%	35%	20%
C	40%	35%	25%
D	30%	40%	30%

The areawise unit sales are expected as follows:

Sales area	Sales (units)
A	2,500
B	2,000
C	3,000
D	6,000
TOTAL	13,500

The selling price has been fixed at ₹ 6 per unit in area A, ₹ 8 per unit in area B, ₹ 12 per unit in area D, and ₹ 10 per unit in area C.

Solution:

Sales area	April	May	June	Total
A	1,000	750	750	2,500
B	900	700	400	2,000
C	1,200	1,050	750	3,000
D	1,800	2,400	1,800	6,000
Total	4,900	4,900	3,700	13,500

Sales budget

Sales area	April			May			June			Total		
	U × P.U.=AMT			U × P.U.=AMT			U × P.U.=AMT			U × P.U.=AMT		
A	1,000	6	6,000	750	6	4,500	750	6	4,500	2,500	6	15,000
B	900	8	7,200	700	8	5,600	400	8	3,200	2,000	8	16,000
C	1,200	10	12,000	1,050	10	10,500	750	10	7,500	3,000	10	30,000
D	1,800	12	21,600	2,400	12	28,800	1,800	12	21,600	6,000	12	72,000
Total	4,900	-	46,800	4,900	-	49,400	3,700	-	36,800	13,500	-	1,33,000

Illustration 8: A manufacturer operates three sales divisions X,Y,Z which sell three branded products A, B and C. The budget committee needs a sales budget for the next year from the following information:

Budget sales units for current year:

Product	X	Y	Z
A	80,000	12,000	12,000
B	6,000	16,000	8,000
C	4,000	24,000	10,000

Actual sales units for the current year based on actual sales to the date and estimated sales for the balance of the year are:

Product	X	Y	Z
A	10,000	16,000	14,000
B	4,000	20,000	10,000
C	2,000	20,000	8,000

The selling prices per unit of A, B and C are ₹ 5, ₹ 10 and ₹ 20 respectively; applicable for all the divisions.

The discussions with divisional sales managers have product "A" is oversold and if the price is increased by 10%, even then it finds a ready market: product is overpriced and the price of it can be reduced by 5%. By incorporating these changes, the sales will be as follows:

Product	X	Y	Z
A	+30%	+40%	+20%
B	-10%	+30%	-10%
C	+10%	+20%	+10%

You are required to prepare the budget for the current year as well as budget for next year.

[CA Modified]

Solution:

Sales Budget for the

Divisions	Brand Product	Budget Current Year			Actual Current Year			Budget Next Year		
		Unit *P.U.=Amount			Unit *P.U.=Amount			Unit *P.U.=Amount		
X	A	80,000	5	4,00,000	10,000	5	50,000	1,04,000	5.5	5,72,000
	B	6,000	10	60,000	4,000	10	40,000	5,400	10	54,000
	C	4,000	20	80,000	2,000	20	40,000	4,400	19	83,600
	Total of X			5,40,000			1,30,000			7,09,600
Y	A	12,000	5	60,000	16,000	5	80,000	16,800	5.5	92,400
	B	16,000	10	1,60,000	20,000	10	2,00,000	20,800	10	2,08,000
	C	24,000	20	4,80,000	20,000	20	4,00,000	28,800	19	5,47,200
	Total of Y			7,00,000			6,80,000			8,47,600
Z	A	12,000	5	60,000	14,000	5	70,000	14,400	5.5	79,200
	B	8,000	10	80,000	10,000	10	1,00,000	7,200	10.0	72,000
	C	10,000	20	2,00,000	8,000	20	1,60,000	11,000	19.0	2,09,000
	Total of Z	-	-	3,40,000	-	-	3,30,000	-	-	3,60,200
	Total of A	1,04,000	5	5,20,000	40,000	5	2,00,000	1,35,200	5.5	7,43,600
	Total of B	30,000	10	3,00,000	34,000	10	3,40,000	33,400	10.0	3,34,000
Total of C	38,000	20	7,60,000	30,000	20	6,00,000	44,200	19.0	8,39,800	
Grand Total		-	-	15,80,000	-	-	11,40,000	-	-	19,17,0000

Illustration 9: ACC Ltd. manufactures two products X and Y and sells them through two divisions: North and south for the submission of sales budget to the budget committee the following information has been made:

Budgeted sales for the current year:

Product	North	South
X	4,000 units at ₹ 9	6,000 units at ₹ 9
Y	3,000 unit at ₹ 24	5,000 unit at ₹ 24

Actual sales for the current year:

Product	North	South
X	5,000 units at ₹ 9	7,000 units at ₹ 9
Y	2,000 unit at ₹ 24	4,000 unit at ₹ 24

Adequate market studies reveal that; product X is popular but underpriced. It is observed that if the price of X is increased by ₹ 1 it will still find the ready market. On the other hand, Y is over priced and the market could absorb more if sales price of Y be reduced by ₹ 4. The management has agreed to do so.

From the information on these price changes and reports from salesman the following estimates have been prepared by divisional managers.

Percentage increase in sales over current budget

Product	North	South
X	+10%	+5%
Y	+20%	+10%

Prepare a sales budget, showing budgeted sales and actual sales of the current year as well as budget for the next year:

[IPCC & TYBAF Modified]

Sales of budget

Sales division	Product	Budget Current Year			Actual Current Year			Budget New Year		
		Unit × P.U.=AMT			Unit × P.U.=AMT			Unit × P.U.=AMT		
North	X	4,000	9	36,000	5,000	9	45,000	4,400	10	44,000
	Y	3,000	24	72,000	2,000	24	48,000	3,600	20	72,000
	Total for North			1,08,000			93,000			1,16,000
South	X	6,000	9	54,000	7,000	9	63,000	6,300	10	63,000
	Y	5,000	24	1,20,000	4,000	24	96,000	5,500	20	1,10,000
	Total for South			1,74,000			1,59,000			1,73,000
	Total of X	10,000	9	90,000	12,000	9	1,08,000	10,700	10	1,07,000
	Total of Y	8,000	24	1,92,000	6,000	24	1,44,000	9,100	20	1,82,000
Grand Total				2,82,000			2,52,000			2,89,000

Illustration 10: (sales budget)

A marketing company submits the following fig. to the first quarter of 2019

Month	Product soap (in units)		
	X	Y	Z
January	2,500	3,000	1,000
February	2,000	2,500	1,000
March	3,000	3,500	1,000

Selling price per unit was X ₹ 10, Y ₹ 20 and Z ₹ 40

Target for the first quarter of 2020

Particulars	Product		
	X	Y	Z
Sales Quantity Increases	20%	10%	10%
Sales price increases	Nil	10%	25%

Prepare the sales budget for the first quarter of 2020.

[T.Y.BAF Modified]

Solution:

Product	January			February			March			Total		
	Units	SP	Amount	Units	SP	Amount	Units	SP	Amount	Units	SP	Amount
X	3,000	10	30,000	2,400	10	24,000	3,600	10	36,000	9,000	10	90,000
Y	3,300	22	72,600	2,750	22	60,500	3,850	22	84,700	9,900	22	2,17,800
Z	1,100	50	55,000	1,100	50	55,000	1,100	50	55,000	3,300	50	1,65,000
Total	-	-	1,57,600	-	-	1,39,500	-	-	1,75,700	-	-	4,72,800

Working : product X; sales quantity increases = 20%

January 2,500 + 20% = 3,000

February 2,000 + 20% = 2,400

March 3,000 + 20% = 3,600

Product Y

January 3000 + 10% = 3,300

February 2,500 + 10% = 2750

March 3,500 + 10% = 3,850

PRODUCT Z : Sales quantity increases = 10%

January 1,000 + 10% = 1,100

February 1,000 + 10% = 1,100

March 1,000 + 10% = 1,100

Selling price increases

X 10 + NIL% = 10

Y 20 + 10% = 22

Z 40 + 25% = 50

Illustration 11: (Production Budget)

Fun Toys Ltd. manufactures a toy monkey with moving parts and a built in voice box. Projected Sales for 5 months are as follows:

Month	Projected Sales (in Units)
July 2004	4,200
August 2004	4,500
September 2004	4,800
October 2004	4,600
November 2004	4,700

Each toy requires direct material from a supplier at ₹ 35 for moving parts. Voice boxes are purchased from another supplier at ₹ 10 per toy. Labour cost is ₹ 20 per toy and variable overhead cost is ₹ 5 per toy. Fixed manufacturing overhead applicable to production is ₹ 45,000 per month. It is the practice of the company to manufacture an output in a month which is equivalent to 1.2 times of the following month's sales. Prepare the production budget and the production cost budget for July 2020 to October 2020.

Solution:**Fun Toys Ltd.**

Particulars	₹ Per unit	₹ Per unit	Total for ----- units ₹ per month
(1) Variable Cst:			
Direct Materials:			
Moving parts	35		
Voice boxes	10	45	
Labour		20	
Variable Overhead		5	
Total Variable cost		70	
(2) Fixed manufacturing overhead			45,000

1. Production Budget

Production during the month = 1.2 times of the following months' sales

	Units
July 1.2*August sales 4,500 units	5,400
August 1.2*September sales 4,800 units	5,760
September 1.2*October sales 4,600 units	5,520
October 1.2*November sales 4,700 units	5,640

2. Production cost budget

Production output (in units)	July	August	September	October
	5,400	5,760	5,520	5,640
	₹	₹	₹	₹
(1) Variable Cost:				
Direct Materials:				
Moving parts (₹ 35 p.u.)	1,89,000	201,600	1,93,200	1,97,400
Voice Boxes ₹ (10 p.u.)	54,000	57,600	55,200	56,400
Labour (20 p.u.)	1,08,000	1,15,200	1,10,400	1,12,800
Variable Overhead (₹ 5 p.u.)	27,000	28,800	27,600	28,200
Total Variable Cost (₹ 70 p.u.)	3,78,000	4,03,200	3,86,400	3,94,800
(2) Fixed manufacturing overhead	45,000	45,000	45,000	45,000
Total Cost	4,23,000	4,48,200	4,31,400	4,39,800

Illustration 12: (Flexible Budget)

A manufacturing company is operating at 75% of its full capacity. It is proposed to offer a price reduction of 5% to 10% depending upon volume desired. Given below are the relevant data:

Capacity	75%	85%	100%
Output (units)	75,000	85,000	1,00,000
Selling price unit	₹ 96	5% off	10% off
Material cost per unit	₹ 40	10% less	15% less
Wages cost per unit	₹ 10	₹ 10	₹ 10

Fixed overheads:

Production ₹ 14,00,000

Selling and distribution ₹ 5,00,000

Variable overheads: (at full capacity)

Selling and administration ₹ 4,40,000

Production ₹ 14,00,000

- (a) Prepare a statement showing variable cost, fixed cost, total cost and profit/loss in terms of ₹ and per unit at 75%, 85% and 100% capacity.
- (b) Indicate which of the three levels is most profitable.

[M. Com., M. Phil. T.Y.BAF modified]

Solution:

Capacity		75%		85%		100%	
Units		75,000		85,000		1,00,000	
		p/u	Amt.	p/u	Amt.	p/u	Amt.
Sales	(a)	96	72,00,000	91.20	77,52,000	86.40	86,40,000
<i>Less: Variable Cost</i>							
Material		40	30,00,000	36	30,60,000	34	34,00,000
Wages		10	7,50,000	10	8,50,000	10	10,00,000
Variable production o/h		14	10,50,000	14	11,90,000	14	14,00,000
Variable selling and admn. o/h		4.40	3,30,000	4.40	3,74,000	4.40	4,40,000
Total variable cost	(b)	68.4	51,30,000	64.4	54,74,000	62.40	62,40,000
Contribution	(a-b)	27.6	20,70,000	26.8	22,78,000	24	24,00,000
<i>Fixed overheads:</i>							
Production		18.67	14,00,000	16.47	14,00,000	14	14,00,000
Selling and Administration		6.67	5,00,000	5.88	5,00,000	5	5,00,000
Profit		2.27	1,70,000	4.45	3,78,000	5	5,00,000

Recommendation: Operating at 100%, i.e., at full capacity is most profitable.

Illustration 13: A Factory is currently working at 50% capacity and produces 30,000 units and also sold each at ₹ 225 per unit. Prepare a Flexible Budget and estimate the profit of the company when it works to 75% and 90% capacity. Assume that all units produced are sold at the same selling price per unit as shown above.

Following information is provided to you:

(i) Variable Expenses:

Materials	₹ 60 per unit
Labours	₹ 40 per unit
Other Expenses	₹ 15 per unit

(ii) Semi-variable Expenses: (at 50% capacity)

Indirect Labour	₹ 1,50,000
Indirect Materials	₹ 2,10,000
General Administrative Expenses	₹ 2,70,000

- | | |
|--|------------|
| Repairs and Maintenance | ₹ 1,20,000 |
| Salesmen Salaries | ₹ 1,80,000 |
| (iii) Fixed Expenses: | |
| Office and Management Salaries | ₹ 5,40,000 |
| Office and Factory Rent and Taxes | ₹ 6,00,000 |
| Sundry Administrative Expenses | ₹ 7,20,000 |
| Depreciation on Machinery and Furniture | ₹ 4,50,000 |
| (iv) Semi-variable expenses remain constant up to 60% of capacity, increasing by 10% between 60% and 80% capacity and by 20% between 80% and 100% capacity. | |
| (v) Rate per unit of variable expenses remains same. | |

[M.Phil Modified]

Solution:**Flexible Budget**

	30,000 units 50%	45,000 units 75%	54,000 units 90%
(i) Variable Expense	₹	₹	₹
Materials	18,00,000	27,00,000	32,40,000
Labours	12,00,000	18,00,000	21,60,000
Other Expenses	4,50,000	6,75,000	8,10,000
(ii) Semi-variable Expenses			
Indirect Labour	1,50,000	1,65,000	1,80,000
Indirect Materials	2,10,000	2,31,000	2,52,000
General Administrative Expenses	2,70,000	2,97,000	3,24,000
Repairs and Maintenance	1,20,000	1,32,000	1,44,000
Salesmen Salaries	1,80,000	1,98,000	2,16,000
(iii) Fixed Expenses			
Office and Management Salaries	5,40,000	5,40,000	5,40,000
Office and Factory Rent and Taxes	6,00,000	6,00,000	6,00,000
Sundry Administrative Expenses	7,20,000	7,20,000	7,20,000
Depreciation on Machinery and Furniture	4,50,000	4,50,000	4,50,000
Total Cost	66,90,000	85,08,000	96,36,000
	₹	₹	₹
	(30,000 × 225)	(45,000 × 225)	54,000 × 225
Sales	67,50,000	1,01,25,000	1,21,50,000
Less: total cost	66,90,000	85,08,000	96,36,000
Profit	60,000	16,17,000	25,14,000

Illustration 14: The following information relates to the productive activities of Delta Ltd. for 3 months ending on 31st March 2008:

Particulars**Variables Expenses: (at 50% capacity)**

₹

– Materials	6,00,000
– Labour	6,40,000
– Salesmen's Commission	95,000
	<u>13,35,000</u>

Semi-variable Expenses: (at 50% capacity)

– Plant Maintenance	62,500
– Indirect Labour	2,47,500
– Salesmen's salaries	72,500
– Sundry	65,000
	<u>4,47,500</u>

Fixed Expense:

– Management Salaries	2,10,000
– Rent and Taxes	1,40,000
– Depreciation of Machinery	1,75,000
– Sundry Office Expenses	2,22,500
	<u>7,47,500</u>

It is further noted that semi-variable expense remain constant between 40% and 70% capacity, increase by 10% of the above figures between 70% and 85% capacity and increased by 15% of the above figures between 85% and 100% capacity.

Fixed expenses remain constant whatever the level of activity may be. Sales at 60% capacity are ₹ 25,50,000, at 80% capacity are ₹ 34,00,000 and at 100% capacity are ₹ 42,50,000.

Assuming that all items produced are sold, you are required to prepare a flexible budget at 60%, 80% and 100% capacity.

[M.Com. T.Y.BAF Modified]

Solution:

**In the Books of Delta Ltd.
Flexible Budget for 3 months ending 31-3-2020**

Capacity	60%	80%	100%
A. Fixed Expenses:			
Management Salaries	2,10,000	2,10,000	2,10,000
Rent and Taxes	1,40,000	1,40,000	1,40,000
Depreciation of Machinery	1,75,000	1,75,000	1,75,000
Sundry Office Expenses	2,22,500	2,22,500	2,22,500
Total (A)	7,47,500	7,47,500	7,47,500

B. Semi-variable Expenses:			
Plant Maintenance	62,500	68,750	71,875
Indirect Labour	2,47,500	2,72,250	2,84,625
Salesmen's salaries	72,500	79,750	83,375
Sundry	65,000	71,500	74,750
Total (B)	4,47,500	4,92,250	5,14,625
C. Variable Expense:			
Materials	7,20,000	9,60,000	12,00,000
Labour	7,68,000	10,24,000	12,80,000
Salesmen's Commission	1,14,000	1,52,000	1,90,000
Total (C)	16,02,000	21,36,000	26,70,000
D. Total Exp. (A + B + C)	27,97,000	33,75,750	39,32,125
E. Sales	25,50,000	34,00,000	42,50,000
F. Profit/Loss	2,47,000	24,250	3,17,875

Illustration 15: (Flexible budget)

Lucky Ltd. is currently operating at 75% of its capacity. In the past two years, the levels of operation were 55% and 65% respectively. Presently the production is 75,000 units. The company is planning for 85% capacity level during 2019-2020. The cost details are as follows:

Particulars	₹		
	55%	65%	75%
Direct Materials	11,00,000	13,00,000	15,00,000
Direct Labour	5,50,000	6,50,000	7,50,000
Factory overheads	3,10,000	3,30,000	3,50,000
Selling overheads	3,20,000	3,60,000	4,00,000
Administrative overheads	1,60,000	1,60,000	1,60,000
TOTAL	24,40,000	28,00,000	31,60,000

Profit is estimated @ 20% on Sales

The following increase, in costs are expected during the year:

(in percentage)

Direct Materials	8
Direct Labour	5
Variable Factory Overhaeds	5
Variable Selling Overheads	8
Fixed Factory Overheads	10
Fixed Selling Overheads	15
Administrative Overheads	10

Prepare Flexible budget for the current year as well as for the period 2019-2020 at 85% of capacity.

[M.Phil & T.Y.BAF Modified]

Solution:

Flexible Budget

Units	75%		85%	
	Total 75,000	Per unit	Total 85,000	Per unit
Variable Cost:				
Direct Material	15,00,000	20.00	18,36,000	21.60
Direct labour	7,50,000	10.00	8,92,500	10.50
Variable Factory Overheads	1,50,000	2.00	1,78,500	2.10
Variable selling Overheads	3,00,000	4.00	3,67,200	4.32
Total Variable Cost	27,00,000	36.00	32,74,200	38.52
Fixed cost :				
Fixed Factory Overhead	2,00,000	2.67	2,20,000	2.59
Fixed Selling Overheads	1,00,000	1.33	1,15,000	1.35
Administrative overheads	1,60,000	2.13	1,76,000	2.07
Total Fixed Cost:	4,60,000	6.13	5,11,000	6.01
Total Cost [VC+FC]	31,60,000	42.13	37,85,200	44.53
Profit	7,90,000	10.54	9,46,300	11.13
Sales	39,50,000	52.67	47,31,500	55.66

Working note:

1. Direct Materials per unit = $15,00,000/75,000 = ₹ 20$
2. Direct labour per unit = $7,50,000/75,000 = ₹10$
3. Factory overheads:
Variable = Difference in cost/Difference in units = $20,000/10,000 = ₹ 2$
Therefore Fixed overheads = $3,50,000 - [7500 \times 2] = ₹ 2,00,000$
4. Selling Overheads: Variable = difference in cost / difference in units = $40000/10000 = ₹ 4$
5. Administrative Overheads Fixed = ₹ 1,60,000

Illustration 16: (Flexible Budget)

A manufacturing company is operating at 75% of normal capacity. It is proposed to offer a price reduction of 5% to 10% depending upon the sales volume desired given below are the relevant data.

	75%	85%	100%
Capacity			
Output (units)	75,000	85,000	1,00,000
Selling price unit	₹ 96	5%off	10%off
Material per unit	₹ 40	₹ 10%less	15%less
Wages per unit	₹ 10	₹ 10	₹ 10

Production	₹ 14,00,000
Selling and administration	₹ 5,00,000
Variable overheads:	
Production	₹ 14,00,000@ normal capacity
Selling and administration	₹ 4,40,000@ normal capacity

- Prepare a single statement to show profit/loss at each level of output
- Compute unit variable cost, unit fixed cost and at different levels of outputs and
- Indicate which of the 3 levels is most profitable

[M.Phil & T.Y.BAF Modified]

Solution:

Units	Currently capacity		85,000		Normal capacity	
	75,000		85,000		1,00,000	
Capacity	75%		85%		100%	
	₹ P.U.	Total ₹	₹ P.U.	Total ₹	₹ P.U.	Total ₹
Sales	96.00	72,00,000	91.20	77,52,000	86.4	86,40,000
(-) Material	40.00	30,00,000	36.00	30,60,000	34.0	34,00,000
Wages	10.00	7,50,000	10.00	8,50,000	10.0	10,00,000
Variable Overheads:						
Production	14.00	10,50,000	14.00	11,90,000	14.0	14,00,000
Selling and administration	4.40	3,30,000	4.40	3,74,000	4.4	4,40,000
Total variable cost	68.40	51,30,000	64.40	54,74,000	62.4	62,40,000
Contribution	27.60	20,70,000	26.80	22,78,000	24.0	24,00,000
Fixed overheads:						
Production	18.67	14,00,000	16.47	14,00,000	14.0	14,00,000
Selling and administration	6.67	5,00,000	5.88	5,00,000	5.0	5,00,000
Profit	2.27	1,70,000	4.45	3,78,000	5.0	5,00,000

Recommendation: operating at 100% i.e., Normal capacity is most profitable

Illustration 17: (Flexible budget)

A factory engaged in manufacturing plastic bucket is working to 40% capacity and produces 10,000 buckets per annum. The present cost break up for one bucket is as under:

Materials	₹ 10
Labour cost	₹ 3
Overhead (60% FIXED)	₹ 5

The selling price is ₹ 20 per bucket. It is decided to work the factory at 50% capacity, the selling price falls by 3%. at 90% capacity the selling price falls by 5% accompanied by a similar fall even points for the same capacity of production.

[CA & T.Y.BAF Modified]

Solution:

Capacity	100%		90%		50%		40% (given)	
Units	25,000		22,500		12,500		10,000	
Particulars	₹		₹		₹		₹	
Sales	20	5,00,000	19	4,27,500	19.4	2,42,500	20	2,00,000
(-)variable costs:								
Material	10	2,50,000	9.5	2,13,750	10	1,25,000	10	1,00,000
Labour	3	75,000	3	67,500	3	37,500	3	30,000
Variable Overheads	2	50,000	2	45,000	2	25,000	2	20,000
Contribution	5	1,25,000	4.5	1,01,250	4.4	55,000	5	50,000
(-)fixed costs	1.2	30,000	1.33	30,000	2.4	30,000	3	30,000
Profit	3.8	95,000	3.17	71,250	2	25,000	2	20,000
P/v ratio = C/S	0.25		0.24		0.23		0.25	
BEP = FC/P/V	30,000/0.25		30,000/0.24		30,000/0.23		30,000/0.25	
BEP(₹)	1,20,000		1,26,667		1,32,273		1,20,000	
BEP (units)	6,000		6,667		6,818		6,000	

Illustration 18: Cost accountant of Norma Ltd. has prepared following flexible budget (₹ 100)

Capacity \Rightarrow	70%	80%
Depreciation	11	11
Insurance	3	3
Indirect labour	10.5	12
Power	17	20
Repairs and maintenance	19	20
Salaries	10	10
Stores consumable	3.5	4

If 100% capacity represents 50 tonnes.

What would be the budgeted overhead cost per tone at production level of 33 tonnes?

If the prime cost is ₹ 5,000 per tone, what is the production cost per tone at 100% capacity utilisation?

[IPCC Modified]

Solution:

Capacity	100%	80%	70%	66%
Quantity (tonne)	50	40	35	33
Variable cost:				
Indirect labour	15	12	10.5	9.9
Stores consumable	5	4	3.5	3.3
Semi-variable cost:				
Power	26	20	17	15.8
Repairs and maintenance	22	20	19	18.6
Fixed cost:				
Depreciation	11	11	11	11.0
Insurance	3	3	3	3.0
Salaries	10	10	10	10.0
Total cost	92	80	74	71.6
Overhead cost per tone i.e. 1,000 kgs	1,840	2,000	2,114.28	2,169.70
(+) prime cost per tone	5,000			
Production cost per tonne	6,840			

Illustration 19:

Calculate the budgeted overhead cost per tone at production level of 35 tonne based on following details at 80% capacity (40 tonnes)

	₹ 000
Depreciation	22
Indirect labour	24
Insurance	6
Power (80% variable)	40
Repairs and maintenance (50% fixed)	40
Salaries	20
Stores consumable	8

Solution:

Capacity	100%		80%		70%	
Production (tonnes)	50		40		35	
Variable:						
Stores consumable		10		8		7.0
Semi-variable:						
Power (80% variable)	40		32		28.0	
(20% fixed)	8	48	8	40	8.0	36.0
Repairs and maintenance						

50% variable	25		20		17.5	
50% fixed	20	45	20	40	20.0	37.5
Depreciation		22		22		22.0
Indirect labour		24		24		24.0
Insurance		6		6		6.0
Salaries		20		20		20.0
Total cost		175		160		152.5
Cost per tone (₹)	₹ 3,500		₹ 4,000		₹ 4,357.14	

Illustration 20: (Flexible budget)

Company ABC Ltd. Produces 10,000 units. The company expenses to 1 unit of the product is listed below:

Direct material	-	₹ 7
Direct labour	-	₹ 5
Other variable expenses	-	₹ 4.5
Administrative overhead	-	₹ 6 (40%variable)
Selling overhead	-	₹ 3 (75%variable)
Production	-	₹ 4 (20% variable)
Purchase of equipment	-	₹ 30,000
Selling price	-	₹ 120

Prepare budget for 70%, 80% and 100% utilisation of the capacity if the details listed above is for 90% utilisation of installed capacity.

[M.Com. & T.Y.BAF Modified]

Solution:

Level activity	70%		80%		90%		100%	
Units	7,778		8,889		10,000		11,111	
	₹ per unit	Total ₹	₹ per unit	Total ₹	₹ per unit	Total ₹	₹ per unit	Total ₹
Variable cost:								
Direct material	7	54,446.00	7	62,223.00	7	70,000	7	77,777.00
Direct labour	5	38,890.00	5	44,445.00	5	50,000	5	55,555.00
Other variable exp.	4.5	35,001.00	4.5	40,000.50	4.5	45,000	4.5	49,999.50
Administrative overhead	2.4	18,667.20	2.4	21,333.60	2.4	24,000	2.4	26,666.40
Selling overhead	2.25	17,500.50	2.25	20,000.25	2.25	22,500	2.25	24,999.75
Production overhead	0.8	6,222.40	0.8	7,111.20	0.8	8,000	0.8	8,888.80
(A)	21.95	1,70,727.10	21.95	1,95,113.55	21.95	2,19,500	21.95	2,43,886.45

Fixed cost:								
Administrative	4.62	36,000	4.04	36,000	3.6	36,000	3.24	36,000
Selling overhead	0.96	7,500	0.84	7,500	0.75	7,500	0.67	7,500
Production overhead	4.11	32,000	3.59	32,000	3.2	32,000	2.88	32,000
(B)	9.69	75,500	8.47	75,500	7.55	75,500	6.79	75,500
Total cost (A+B)	31.64	2,46,227.10	30.42	2,70,613.55	29.5	2,95,000	28.74	3,19,386.45
(+) profit	88.34	6,87,132.90	89.55	7,96,066.46	90.5	9,05,000	91.25	10,13,933.55
Selling price	120	9,33,360	120	10,66,680	120	12,00,000	120	13,33,320

Illustration 21: (Flexible Budget)

The following information at 50% capacity is given. Prepare a flexible budget and forecast the profit or loss at 60%, 70% and 90% capacity.

	Expenses at 50% capacity (₹)
Fixed Expenses	
Salaries	50,000
Rent and taxes	40,000
Depreciation	60,000
Administrative expenses	70,000
Variable expenses	
Materials	2,00,000
Labour	2,50,000
Others	40,000
Semi-variable expenses	
Repairs	1,00,000
Indirect labour	1,50,000
Others	90,000

It is estimated that fixed expenses will remain constant at all capacities. Semi-variable expenses will not change between 45% and 60% capacity, will rise by 10% between 60% and 75% capacity, a further increase of 5% when the capacity crosses by 75%.

Estimated sales:

Capacity	₹
60%	11,00,000
70%	13,00,000
90%	15,00,000

[M.Phil. Modified]

Solution:**Flexible budget**

Particulars Capacity levels	50%	60%	70%	90%
	₹	₹	₹	₹
Variable expenses:				
Material	2,00,000	2,40,000	2,80,000	3,60,000
Labour	2,50,000	3,00,000	3,50,000	4,50,000
Others	40,000	48,000	56,000	72,000
Total variable exp.	4,90,000	5,88,000	6,86,000	8,82,000
Semivariable exp.				
Repairs	1,00,000	1,00,000	1,10,000	1,15,000
Indirect labour	1,50,000	1,50,000	1,65,000	1,72,500
Others	90,000	90,000	99,000	1,03,500
Total Semi- variable exp.	3,40,000	3,40,000	3,74,000	3,91,000
Fixed expenses				
Salaries	50,000	50,000	50,000	50,000
Rent and taxes	40,000	40,000	40,000	40,000
Depreciation	60,000	60,000	60,000	60,000
Administration exp.	70,000	70,000	70,000	70,000
Total Fixed exp.	2,20,000	2,20,000	2,20,000	2,20,000
Total cost	10,50,000	11,48,000	12,80,000	14,93,000
Add/less: profit/loss	N.A	48,000	20,000	7,000
Sales	N.A	11,00,000	13,00,000	15,00,000

Working:

Semi-variable expenses:

At 60% = same as at 50% capacity level

At 70% = 10% increases to given amount at 50% capacity level

Repairs = 1,00,000 + 10% = 1,10,000

Indirect labour = 1,50,000 + 10% = 1,65,000

Others = 90,000 + 10% = 99,000

At 90% = 15% {i.e. 10% + 5%} increases to given amount at 50% capacity level

Repairs = 1,00,000 + 15% = 1,15,000

Indirect labour = 1,50,000 + 15% = 1,72,000

Others = 90,000 + 15% = 1,03,500

Variable expenses:

Material At 50% 2,00,000

60% ? = 2,40,000

	70%	?	=	2,80,000
	90%	?	=	3,60,000
Labour	At 50%			2,50,000
	60%	?	=	3,00,000
	70%	?	=	3,50,000
	90%	?	=	4,50,000
Others	At 50%			40,000
	60%	?	=	48,000
	70%	?	=	56,000
	90%	?	=	72,000

Illustration 22: (Flexible Budget)

AB Ltd. has furnished the following estimation pertaining to Product "A" at 80% of its normal capacity level for the quarter ending March 31, 2020.

Sales	₹ 6,00,000
Administrative costs :	
Office salaries	₹ 90,000
General expenses	2% of Sales
Depreciation	₹ 7,500
Rates and taxes	₹ 8,750
Selling Costs:	
Salaries	8% of sales
Travelling exp.	2% of sales
Sales office expenses	1% of sales
General office expenses	1% of sales
Distribution Costs:	
Wages	₹ 15,000
Rent	1% of sales
Other expenses	4% of sales

Prepare the budget for the total administration, Selling and Distribution expenses at 70% & 90% capacity levels.

[M.Phil & T.Y.BAF Modified]

Solution:

AB Ltd.
Flexible Budget of Product "A"

Particulars Capacity levels	70%	80% Given	90%
	₹	₹	₹
Sales (A)	5,25,000	6,00,000	6,75,000
Less: Costs:			
(1) Administrative Costs:			
Office salaries	90,000	90,000	90,000
General expenses (2% of sales)	10,500	12,000	13,500
Depreciation	7,500	7,500	7,500
Rates and Taxes	8,750	8,750	8,750
Total Administrative Costs (B)	1,16,750	1,18,250	1,19,750
(2) Selling costs:			
Salaries (8% of sales)	42,000	48,000	54,000
Travelling expenses (2% of sales)	10,500	12,000	13,500
Sales office expenses (1% of Sales)	5,250	6,000	6,750
General Expenses (1% of sales)	5,250	6,000	6,750
Total Selling Costs (C)	63,000	72,000	81,000
(3) Distribution Costs:			
Wages	15,000	15,000	15,000
Rent (1% of sales)	5,250	6,000	6,750
Other expenses (4% of sales)	21,000	24,000	27,000
Total Distribution Costs (D)	41,250	45,000	48,750
Total Costs (e) = [B+C+D]	2,21,000	2,35,250	2,49,500
Profits (F) = [A-E]	3,04,000	3,64,750	4,25,500

Illustration 23: PRONTO Company plant had operated at 60% capacity in the year 2019. The summarised results were;

Sales – ₹ 40 lakhs Material cost ₹12 lakhs
Direct labour ₹ 6 lakhs Overheads ₹ 10 lakhs

It is expected that market will expand to match 75% capacity, when overheads are expected to touch ₹ 12 lakhs, during 2020

(A) Based on above information calculate

- (1) Break even points in the years 2019-2020
- (2) Margin of safety in 2020

(B) Further capacity utilisation (increases in sales quantity) can be achieved only with 5% price reduction.

Calculate the sales target and capacity utilisation to earn profit of ₹ 17 lakhs in the year 2020.

[CA & T.Y.BAF Modified]

Solution:

	2019	2020
Capacity	60%	75%
Material	12	15
Labour	6	7.5
Overheads:		
Variable overheads	8	10
Fixed overheads	2	2
Sales	40	50.0
(-)variable costs	26	32.5
Contribution	14	17.5
(-)fixed costs	2	2.0
Profit	12	15.5

60% 10 10 12
 75% 12 VC FC VC FC
 15% 2 8 2 10 2
 $15 \times 4 = 60$ $2 \times 4 = 8$ variable cost
 $15 \times 5 = 75$ $2 \times 5 = 10$ variable cost

For variable overhead = differential cost/ differential capacity

	2019	2020
P/V Ratio	0.35	0.35
BEP	5.71	5.71
MOS	34.29	44.29
MOS%	85.71	88.57%

	PRICE ↓ 5%	
Sales	47.5	60.17
Less: variable cost	32.5	41.17
Contribution	15.0	19.00
Less: fixed cost	2.0	2.00
Profit	13.0	17.00

$P/V \text{ Ratio} = C/S = 15/47.5$
 $= 0.31$

Sales required = Target profit + Fixed cost/P/V Ratio
 $= 17 + 2/0.31 = ₹ 60.17 \text{ lakhs}$

Exercise

1. The Bright Ltd. manufactures two brands of pen – one sold under the name of 'Bright' and another under name of 'Hans'. The sales department of the company has three departments in different areas of country.

The sales budget for the year ending 31st December, 2020 were:

Bright

Department I	3,00,000
Department II	5,62,500
Department III	1,80,000

Hans

Department I	4,00,000
Department II	6,00,000
Department III	20,000

Sales prices are ₹ 3 and ₹ 1.20 in all departments.

It is estimated that by forced sales promotion the sale of 'Hans' in department I will increase by 1,75,000. It also expected that by increasing production and arranging extensive advertisement department III will be enabled to increase the sale of 'Hans' to 50,000.

It is recognised that the estimated sales by department II represent an unsatisfactory target. It is agreed to increase both estimates by 20%.

Prepare a sales budget for the year to 31st December, 2020.

Ans.:

	Bright	Hans
Department I	9,00,000	15,90,000
Department II	20,25,000	28,89,000
Department III	5,40,000	6,24,000

2. The sales director of a manufacturing company reports that next year he expects to sell 54,000 units of a certain product.

The production manager consults the shopkeeper and casts his figure as follows:

Two kinds of raw material, A and B, are required for manufacturing the product. Each unit of the product required 2 units of A and 3 units of B. The estimated opening balances at the commencement of the next year are:

Finished : 10,000 units

A : 12,000 units

B : 15,000 units

The desirable closing balance at the end of the next year are:

Finished products : 14,000 units

A : 13,000 units

B : 16,000 units

Draw up a quantitative chart showing the material purchase budget for the next year.

Ans.:

	A	B
Units	59,000	59,000
₹	1,18,000	1,77,000

3. It is estimated that on 1st January, 2020 the Alpha Manufacturing Co. Ltd. will have the following raw material inventory:

Type of materials	Quantity	Price (₹)	Amount (₹)
L	700	3	2100
M	15 tons	35	525
N	1500 kg.	0.75	1125
O	800 gallons	1.00	800
P	10,500	0.20	2100
			6650

The management summarised the consumption of different types of raw material for various departments in the following manner:

Materials	I	II	III	IV
L units	4500	–	3000	500
M tons	11	3	–	4
N kg	–	600	700	1350
O gallons	350	700	–	–
P units	5600	6300	1500	800

The following inventory at 31st December, 2020 is desired:

L : 800

M : 7 tons

N : 1050 kg.

O : 750 gallons

P : 600

Assuming that all prices will remain constant, prepare the purchase budget.

Ans.:

L	M	N	O	P
24,300	350	1650	1,000	680

4. The golden company plans to sell 1,08,000 units of a certain product line in the first fiscal quarter 1,20,000 units in the second quarter 1,32,000 units in the third quarter and 1,56,000 units in the fourth quarter and 1,38,000 units in the first quarter of the following year. At the beginning of the first quarter of the current year there are 18,000 units of product in the stock. At the end of each quarter, the company plans to have an inventory equal to one sixth of the sales of the sales for the next fiscal year.

Ans.:

1,10,000

1,22,000

1,36,000

1,53,000

5. Shangrilla Foods Products Limited has prepared the following sales budget for the first five – Year months of 2020.

Sales budget (in units)

January	10,800
February	15,600
March	12,200
April	10,400
May	9,800

The inventory of finished products at the end of every month is to be equal to 25 per cent of the sales estimate for the next month. On 1st January, 2020 there were 2,700 units of product on hand. There is no work in process at the end of any month.

Every unit of product requires two types of materials in the following quantities:

Material A : 4 kg, Material B : 5 kg

Material equal to one half of the next month's production are to be in hand at the end of every month. This requirements was met on 1st January, 2020.

Budgeted prices of the purchase of materials are:

Material A : ₹ 3 per kg., Material B : ₹ 2 per kg.

Prepare a material budget for the first quarter of 2020 in a logical form showing the quantities of each type of material to be purchased every month. Also prepare a purchase budget.

[M.Com. Modified]

Ans.:

6. The following are the estimated sales of a company for eight months ending 30th October 2020.

Months	Estimated sales (units)
April 2020	12,000
May 2020	13,000
June 2020	9,000
July 2020	8,000
Aug 2020	10,000
Sept. 2020	12,000
Oct. 2020	14,000
Nov. 2020	12,000

As a matter of policy the company maintain the closing balance of finished goods and raw materials as follows:

Stock item. Closing balance of month

Finished goods 50% of the estimated sales for the next month

Raw materials estimated consumption for the next month

prepare production budget (in units) and raw material purchase budget (in units and cost) of the company for the half year ending 30th September 2020.

Ans.:

Questions for Self-practice

I. Short Question

1. What is a budget?
2. Who decides the budget period?
3. What is budget period?
4. What is the use of a budget?
5. What is budget manual?
6. Give one function of budget committee?
7. What is the basis of sales budget?
8. Mention any two factors which decides production budget?
9. What is flexible budget?
10. Why is budget controller appointed?

II. Short Notes

1. Budgetary Control
2. Objectives of Budgetary Control
3. Budget Key Factor
4. Flexible Budget
5. Master Budget

Objective Questions

I. Fill in the Blanks

1. Budget is drawn for _____.
2. Key factor is also known as _____.
3. _____ requires classifications of cost as fixed, variable and semi-variable.
4. Flexible budget is drawn for _____ level of activity.
5. _____ budget is prepared for a longer period.
6. _____ is a summary of all the functional budgets.
7. _____ shows estimate of sales in future.
8. Flexible budget is useful for _____.
9. Budget defines _____ of a concerned manager.
10. _____ shows budgeted receipts and payments.

[Ans.: 1. Future, 2. Limiting factor, 3. Flexible budget, 4. Fixed, 5. Capital, 6. Master budget, 7. Sales budget, 8. Control, 9. Responsibility, 10. Cash budget.]

II. True or False

1. Budget is prepared for the future period.
2. The scarce factor of production is known as key factor.
3. Flexible budget is drawn for one level of activity.

4. Flexible budget is drawn for multiple levels of activities.
5. A budget is expressed in financial terms only.
6. Capital expenditure budget is prepared for a longer period.
7. Master budget is a summery of all the functional budgets.
8. Budget period depends on management policy.
9. Production budget is expressed in quantity and cost.
10. Sales budget is prepared by production manager.

[Ans.: True: (1, 2, 6, 7, 8, 9), False: (3, 4, 5, 10).]

III. Match the Columns

Group 'A'	Group 'B'
1. Budget	(i) Future oriented
2. Key factor	(ii) Drawn for one level
3. Fixed budget	(iii) Drawn for multiple levels
4. Flexible budget	(iv) Limiting factors
5. Master budget	(v) Summary of all functional budgets
6. Budgetary control	(vi) Estimates of sales
7. Sales budget	(vii) Estimate of production
	(viii) Control through budgets

[Ans.: 1. (i), 2. (vi), 3. (ii), 4. (iii), 5. (v), 6. (viii), 7. (vii).]

IV. Multiple Choice Questions

1. One of the following is not a basic element of a budget:

(a) Defines the responsibility of each employee	(b) Comprehensive plan
(c) Expressed in financial terms	(d) Future plan for a specified period
2. Information to prepare flexible budget includes:
 - (a) Total fixed cost, total variable cost
 - (b) Total fixed cost, total variable cost and capacity
 - (c) Total fixed cost, variable cost per unit and several levels of activity.
 - (d) None of the above
3. Flexible budget are useful for
 - (a) Planning purpose only
 - (b) Planning, performance evaluation and feedback control
 - (c) Control of performance only
 - (d) None of the above
4. A flexible budget takes into account

(a) Fixed cost only	(b) Variable cost only
(c) Semi-variable cost only	(d) Fixed, variable and semi-variable cost

5. A budget is prepared for
 - (a) One year
 - (b) One month
 - (c) 6 months
 - (d) A specified period
6. Master budget is a summary of
 - (a) Cash budget
 - (b) Sales budget
 - (c) Production budget
 - (d) All functional budget
7. Budget period depends on
 - (a) Type of budget
 - (b) Management policy
 - (c) Government policy
 - (d) None of the above
8. Budgetary control system is costly for
 - (a) Large organisation
 - (b) Small organisation
 - (c) Public sector organisation
 - (d) None of the above
9. Production budget is expressed in
 - (a) Quantity only
 - (b) Cost only
 - (c) Quantity and cost
 - (d) None of the above
10. Sales budget shows
 - (a) Estimate of future sales
 - (b) Estimate of future production
 - (c) Estimate of inventory
 - (d) None of the above

[Ans.: 1. (a), 2. (c), 3. (b), 4. (d), 5. (d), 6. (d), 7. (b), 8. (b), 9. (a), 10. (a).]



ABSORPTION COSTING AND MARGINAL COSTING, COST VOLUME AND PROFIT ANALYSIS

Introduction

Costing is the process of determining the cost of doing something. Costing includes the techniques and processes of ascertaining cost. We dealt with different methods of costing, different techniques of costing and finally classification of costs under various heads.

Marginal Cost determines the rate of change in costs if the volume of output is increased or decreased by one unit. Marginal costing is a technique of costing concerned with the changes in costs and profits resulting from changes in the volume of output. Marginal costing is very helpful in decision-making and it most widely used profit planning techniques. The cost-volume-profit analysis shows the relationship among unit sale price, variable cost, sales volume, sales mix and fixed cost.

Concept of Marginal Costing

According to Institute of Cost and Management Accounting, London, Marginal costing is defined as “the ascertainment of marginal cost and of the effect on profit of changes in volume or type of output by differentiating between fixed costs and variable cost”. Marginal costing is a technique of costing concerned with the changes in costs and profits resulting from changes in the volume of output. Marginal costing is also known as ‘**Variable Costing**’.

Features of Marginal Costing

The technique of marginal costing is based on the distinction between product costs and period costs. Only the variable costs are regarded as the cost of the product while the fixed cost is treated as period costs.

Characteristics of marginal costing are:

1. It is a technique of analysis and determination of costs to help management in decision making.
2. All elements of costs are classified into variable and fixed components. Even semi-variable costs are classified into variable and fixed components.
3. The variable costs are regarded as the cost of the products.
4. Fixed costs are treated as period cost and are charged to profit and loss account for the period for which they are incurred.
5. The stock of finished goods and work-in-progress are valued at marginal costs only.

Variable and Absorption costing are techniques of costing wherein variable costing considers only variable costs for the purpose of product costing, inventory valuation and for other important management decisions. In absorption costing, total costs are taken into consideration for these

purposes. Direct material, direct labour and variable overheads constitute the only relevant costs in variable costing whereas the full/absorption costing technique recognises fixed overheads also as a product costs in addition to material, labour and variable overheads.

The two techniques are not mutually exclusive. Full costing is needed while preparing income statements for external reporting and for tax purpose, while variable costing is extensively used for internal purpose in decision-making.

Advantages and Disadvantages of Marginal Costing Technique

Advantages

1. Marginal costing is simple to understand.
2. By not charging fixed overhead to cost of production, the effect of varying charges per unit is avoided.
3. It prevents the illogical carry forward in stock valuation of some proportion of current year's fixed overhead.
4. The effects of alternative sales or production policies can be more readily available and assessed, and decisions taken would yield the maximum return to business.
5. It eliminates large balances left in overhead control accounts which indicate the difficulty of ascertaining an accurate overhead recovery rate.
6. Practical cost control is greatly facilitated. By avoiding arbitrary allocation of fixed overhead, efforts can be concentrated on maintaining a uniform and consistent marginal cost. It is useful to various levels of management.
7. It helps in short-term profit planning by breakeven and profitability analysis, both in terms of quantity and graphs. Comparative profitability and performance between two or more products and divisions can easily be assessed and brought to the notice of management for decision making.

Disadvantages

1. The separation of costs into fixed and variable is difficult and sometimes gives misleading results.
2. Normal costing systems also apply overhead under normal operating volume and this shows that no advantage is gained by marginal costing.
3. Under marginal costing, stocks and work in progress are understated. The exclusion of fixed costs from inventories affect profit, and true and fair view of financial affairs of an organisation may not be clearly transparent.
4. Volume variance in standard costing also discloses the effect of fluctuating output on fixed overhead. Marginal cost data becomes unrealistic in case of highly fluctuating levels of production, e.g., in case of seasonal factories.
5. Application of fixed overhead depends on estimates and not on the actuals and as such there may be under or over absorption of the same.
6. Control affected by means of budgetary control is also accepted by many. In order to know the net profit, we should not be satisfied with contribution and hence, fixed overhead is also

a valuable item. A system which ignores fixed costs is less effective since a major portion of fixed cost is not taken care of under marginal costing.

7. In practice, sales price, fixed cost and variable cost per unit may vary. Thus, the assumptions underlying the theory of marginal costing sometimes becomes unrealistic. For long term profit planning, absorption costing is the only answer.

Illustration 1: Hydro Electric Ltd. furnishes the following information from its cost records for the first quarter of the current year.

Normal production (units)	1,000
Actual production (units)	1,100
Actual overheads per quarter at normal production	4,000
Other expenses per quarter	300
Standard fixed overhead rate per unit	4
Variable costs per unit	6
Sales volume (selling price is ₹ 14)	NIL

Prepare the income statement under absorption and variable costing.

Solution:

Income Statement (Absorption Costing)

Particulars	₹	₹
Sales Revenue		NIL
<i>Less:</i> Total Cost of Manufacturing:		
Variable Costs (1,100 × ₹ 6)	₹ 6,600	
Fixed Overheads (1 100 × ₹ 4)	4,400	
	11,000	
<i>Less:</i> Cost of Inventory at the end of the year (1,100 × ₹ 10)	11,000	
Cost of Goods Manufactured and Sold		NIL
Gross Margin (Unadjusted)		NIL
Capacity Variance (Favourable) (Overabsorbed 100 × ₹ 4)		400
Gross Margin (Adjusted)		400
<i>Less:</i> Other Expenses		300
Net Income before Taxes		100

Income Statement (Variable Costing)

Particulars	₹	₹
Sales Revenue		NIL
<i>Less:</i> Variable Costs (Production Costs) (1,100 × ₹ 6)	₹ 6,600	
<i>Less:</i> Cost of Inventory at the end to the year (1,100 × ₹ 6)	6,600	
Cost of Goods Manufactured and Sold		NIL
Contribution		NIL
<i>Less:</i> Fixed Costs:		

Fixed Overheads	4,000	
Other Expenses	300	(4,300)
Net Income before Taxes (Loss)		(4,300)

Inference: Under absorption costing, the net income before taxes is ₹ 100 while in marginal costing, net income before taxes is (₹ 4300) (loss). This significant difference can be attributed to the fact that under absorption costing, the fixed manufacturing overheads are included in inventory, whereas in variable costing, inventory carries only variable costs.

Inventory Valuation

Underabsorption Costing	11,000
Inventory Valuation under Variable Costing	<u>6,600</u>
Difference	<u>4,400</u>

(This difference is equal to difference between net income before taxes under absorption costing and variable costing.)

Difference between Absorption Costing and Marginal Costing

Absorption Costing	Marginal Costing
It is known as full costing. Both fixed and variable are included to ascertain the cost.	Only variable costs are included. Fixed costs are recovered from contribution.
Different unit costs are obtained at different levels of output because of fixed expenses remaining the same.	Marginal cost per unit remain same at different levels of output because variable expenses vary in the same proportion in which output varies.
Difference between sales and total cost (marginal cost and fixed cost) is profit.	Difference between sales and marginal cost is contribution and difference between contribution and fixed cost is profit or loss.
A portion of fixed cost is carried forward to the next period because closing stock of work-in-progress and finished goods is valued at cost of production which is inclusive of fixed cost.	Stock of work-in-progress and finished goods are valued at marginal cost. Fixed cost of a particular period is charged to that very period and is not carried over to the next period.
The apportionment of fixed expenses on an arbitrary basis gives rise to overabsorption or underabsorption of overheads	Only variable cost are charged to products hence marginal costing does not lead to overabsorption or underabsorption of fixed overheads.
It affects managerial decisions in the areas such as whether to accept the export order or not., whether to buy or manufacture, etc.	It is very helpful in taking managerial decisions because it takes into consideration the additional cost involved only assuming fixed expenses remaining constant.
Costs are classified according to functional basis such as production cost, office and administrative cost and selling and distribution costs.	Costs are classified according to the behaviour of costs – fixed costs and variable costs.
It fails to establish relationship of cost, volume and profit	CVP relationship is an integral part of marginal costing.

Marginal Cost: According to C.I.M.A., London, “Marginal Cost means the amount at any given volume of output by which aggregate costs are changed if the volume of output is increased or decreased by one unit”. Marginal cost per unit remains unchanged irrespective of the level of activity or output. It is also known as Variable Cost. Marginal cost is the sum total of direct material cost, direct labour cost, variable direct expenses and all variable overheads. The marginal cost of producing a unit declines as output increases.

Advantages of Marginal Costing

1. In order to forecast profits accurately, it is essential to ascertain the relationship between cost and profit on one hand and volume on the other.
2. Marginal Costing is helpful in setting up flexible budget which indicates cost at various levels of activities.
3. Marginal Costing assist in evaluating performance for the purpose of control.
4. Marginal Costing may assist management in formulating pricing policies by projecting the effect of different price structures on cost and profit.

Cost Drivers: The activities that cause costs to be incurred are called “Cost Drivers”. A fixed cost remains unchanged in total as the level of activity (cost drivers) varies. If activity increases or decreases say by 20%, the total fixed costs remain the same, e.g., depreciation, property tax, rent to landlord, etc. But fixed costs per unit will change.

A variable cost changes in total in direct proportion to a change in the level of activity or cost driver. If activity increases, say by 20%, total variable cost also increases by 20%. The total variable cost increases proportionately with activity. Variable cost is fixed per unit but varies in total.

Contribution: It is the difference between sales and variable cost. It may be defined as the excess of selling price over variable cost per unit. It is also termed as Contribution Margin or Gross Margin.

Contribution = Sales – Variable Cost

Contribution (per unit) = Selling Price – Variable Cost per unit

Contribution = Fixed Cost + Profit (– Loss)

Advantages of Contribution: The concept of contribution is a valuable aid to management in making managerial decisions. It includes:

1. It helps the management in the fixation of selling prices.
2. It assists in determining the break-even point.
3. It helps management in the selection of a suitable product mix for profit maximisation.
4. It helps in choosing from among alternative methods of production.
5. It helps the management in deciding whether to purchase or manufacture, add a new product or not, etc.

Cost-Volume-Profit (CVP) Analysis: This technique summarises the effects of changes in an organisation’s volume of activity on its costs, revenue and profit. CVP analysis can be extended to cover the effects on profit of changes in selling prices, changes in sales volume, changes in product mix, etc. It provides management with a comprehensive overview of the effects on revenue and costs of all types of short-run financial changes. Since CVP analysis explores the fundamental relationship

between cost-volume-profit variables, it becomes easier to recognise certain level of output or a certain volume of sales that equates cost with revenue. Such level is termed as break-even point. Break-even analysis is an integral part of CVP analysis.

Break-even Chart: It is a graphic or visual presentation of the relationship between cost, volume and profit. It indicates the point of production at which there is neither profit nor loss. It also indicates the estimated profit or loss at different levels of production. While constructing the chart, the following assumption is normally considered.

- (a) Costs are classified into fixed and variable costs.
- (b) Fixed costs shall remain fixed during the relevant volume range of graph.
- (c) Variable cost per unit will remain constant during the relevant volume range of graph.
- (d) Selling price per unit will remain constant.
- (e) Sales mix remains constant.
- (f) Production and sales volume are equal.
- (g) There exists a linear relationship between costs and revenue.
- (h) Linear relationship is indicated by way of straight line.

Break-even Point: BEP is the volume of activity where the organisation's revenues and expenses are equal. At a particular amount of sales, the organisations have no profit or loss. It normally breaks even.

The general formula for computing the break-even sales volume in units is:

$$\text{BEP (in units)} = \frac{\text{Fixed expenses}}{\text{Contribution margin per unit}}$$

$$\text{BEP (in Rupee)} = \frac{\text{Fixed expenses}}{\text{Contribution sales ratio}}$$

Limitations of Marginal Costing

There are certain limitations which can be described as follows:

1. **Suitability:** The techniques of marginal costing cannot be applied to all the concerns. When a concern needs to carry large stocks by way of work-in-progress, the technique becomes redundant. In addition, the marginal costing techniques are not suitable to industries working on contract basis.
2. **Inventory valuation difficulties:** Since the work-in-progress and the closing inventories are valued at marginal cost basis, it will not be a sound decision from the Balance Sheet point of view. The main focus on the true and fair value concept gets diluted and the very purpose of exhibiting the financial position will get defeated.
3. **Segregation of costs:** Though the marginal costing principles call for the differentiation of costs into fixed and variable, in actual practice, it becomes difficult to classify them precisely. Many overheads which appear to be fixed and variable may not exactly align at various levels of production. There is no logical method to segregate semi-variable expenses into fixed and variable.

4. **Time factor:** The marginal costing ignores the time factor which is very important in all managerial decisions. Ignoring the time value factor would naturally relate to unreliable and incomplete basis for comparing two alternative jobs.
5. **Sales emphasis:** Marginal costing principles are basically a sales-oriented concept. While the selling function gets the prominence, other functions are not given equal weightage. This would be a major setback.

Revenue Statement

Particulars	Amount ₹	P.U.
Sales	XX	
Less: Variable Cost	(X)	
Contribution	XX	
Less: Fixed Cost	(X)	
Profit		

1. Profit Volume Ratio

A. When sales and variable cost given, P/V Ratio = $\frac{\text{Contribution}}{\text{Sales}} \times 100$

Where, Contribution = Sales – Variable Cost

B. When sales and profit for two consecutive term given, P/V Ratio

$$= \frac{\Delta \text{ in Profit}}{\Delta \text{ in Sales}} \times 100$$

2. Break-even Point

A. Break-even Point (in Unit) = $\frac{\text{Fixed Cost}}{\text{Contribution Per Unit}}$

B. Break-even Point (in Sales) = $\frac{\text{Fixed Cost}}{\text{P/V Ratio}}$

3. Desired Sales = $\frac{\text{Fixed Cost} + \text{Desired Profit}}{\text{P/V Ratio}}$

Margin of Safety (MOS)

Every enterprise tries to know how much above they are from the breakeven point. This is technically called margin of safety. It is calculated as the difference between sales or production units at the selected activity and the breakeven sales or production.

Margin of safety is the difference between the total sales (actual or projected) and the breakeven sales. It may be expressed in monetary terms (value) or as a number of units (volume). It can be expressed as profit / P/V ratio. A large margin of safety indicates the soundness and financial strength of business.

Margin of safety can be improved by lowering fixed and variable costs, increasing volume of sales or selling price and changing product mix, so as to improve contribution and overall P/V ratio.

$$\begin{aligned}\text{Margin of safety} &= \text{Sales at selected activity} - \text{Sales at BEP} \\ &= \frac{\text{Profit at selected activity}}{\text{P/V ratio}}\end{aligned}$$

Margin of safety is also presented in ratio or percentage as follows:

$$= \frac{\text{Margin of safety (sales)} \times 100}{\text{Sales at selected activity}}$$

The size of margin of safety is an extremely valuable guide to the strength of a business. If it is large, there can be substantial falling of sales and yet a profit can be made. On the other hand, if margin is small, any loss of sales may be a serious matter. If margin of safety is unsatisfactory, possible steps to rectify the causes of mismanagement of commercial activities as listed below can be undertaken.

- (a) Increasing the selling price – It may be possible for a company to have higher margin of safety in order to strengthen the financial health of the business. It should be able to influence price, provided the demand is elastic. Otherwise, the same quantity will not be sold.
- (b) Reducing fixed costs
- (c) Reducing variable costs
- (d) Substitution of existing product(s) by more profitable lines
- (e) Increase in the volume of output
- (f) Modernisation of production facilities and the introduction of the most cost effective technology

Implications of the Angle of Incidence

It is formed by the intersection of sales line and total cost line at the Break Even Point. It shows the rate at which the organisation is earning profit once the BEP is reached. This angle provides useful information about the rate at which profits are being made. The larger the angle the higher the rate of profit and vice-versa. The angle of incidence can be studied in conjunction with margin of safety. A large angle of incidence together with a high margin of safety indicates an extremely favourable situation. This can be shown by plotting a Break-Even Chart.

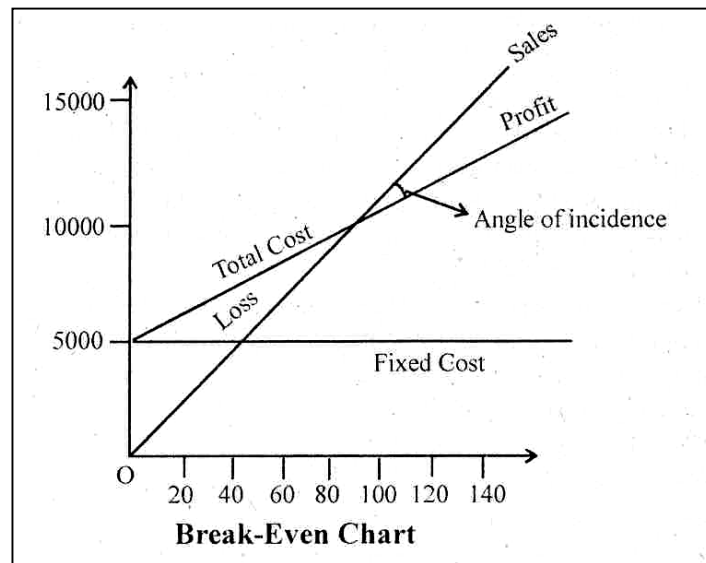

Importance of Marginal Costing in Decision Making Function

In marginal costing, it is presumed that variable costs are related to output and Fixed costs are related to the period. Fixed costs are charged off to the P&L A/c.

Marginal costing necessitates the analysis of costs into fixed and variable. These types of costs behave differently with changes in the volume of output. The variable cost varies directly in proportion to change in the volume of output, which means that variable cost per unit remains constant regardless of the levels of output. Fixed costs, on the other hand, remain fixed at the same level regardless of changes in the volume of output, and vary per unit inversely with the change in total with time rather than with the level of output. For this reason fixed costs are also known as time or period costs because they accrue with the passage of time irrespective of the volume of output. Fixed cost is also called by other names like standby cost, constant cost, capacity cost, etc. Variable costs are also known as product costs as these are related to volume of output. Variable cost is also termed as direct cost, marginal cost, activity cost, volume cost, or out-of pocket cost. Semi-variable cost is one which is partly fixed and partly variable. The fixed part of this cost is segregated and merged into the variable cost.

Marginal costing is basically concerned with the determination of product cost which consists of the total costs less the fixed costs i.e. direct materials, direct labour, direct expenses and variable overhead. Thus, marginal cost is the variable cost (which forms part of product cost) and does not include fixed cost. Fixed costs are not included in the cost of production because the former bear relation to certain period of time and also vary per unit of production.

The technique of marginal costing is a valuable aid to management for decision making in many key areas such as the following:

- (a) The price at which a product should be sold.
- (b) Determination of volume of output.
- (c) Utilisation of surplus capacity.
- (d) Submission of tenders and quotations.

- (e) Acceptance of special order e.g. export order.
- (f) Make or buy a component.
- (g) Economic feasibility of major (capital) projects.
- (h) Replacement of a machinery.
- (i) Determining optimum product or sales mix.
- (u) Operate the plant or shut it down, etc.
- (k) Suspension or permanent closing down of a business.

Illustrations

Illustration 2: Following information is available.

Year	Sales	Profit
2019	10,00,000	1,00,000
2020	15,00,000	2,00,000

Calculate:

- (a) Profit Volume Ratio.
- (b) Sales required to earn profit of ₹ 4,00,000.
- (c) Profit when sales are 20,00,000.

[M.Com. Modified]

Solution:

$$\begin{aligned}
 \text{(a) P/V Ratio} &= \frac{\text{Change in Profit}}{\text{Change in Sales}} \times 100 \\
 &= \frac{2,00,000 - 1,00,000}{15,00,000 - 10,00,000} \times 100 \\
 &= \frac{1,00,000}{5,00,000} \times 100 \\
 &= 20\% \\
 \text{(b) Desired Sales} &= \frac{\text{Fixed Cost} + \text{Profit}}{\text{P/V Ratio}} \\
 \text{Fixed Cost} &= \text{Contribution} - \text{Profit} \\
 \therefore \text{Contribution} &= \text{Sales} \times \text{P/V Ratio} \\
 \therefore \text{Contribution} &= 15,00,000 \times 20\% \\
 &= 3,00,000 \\
 \text{Fixed Cost} &= 3,00,000 - 2,00,000 \\
 &= 1,00,000 \\
 \therefore \text{Desired sales} &= \frac{1,00,000 + 4,00,000}{20\%} \\
 &= \frac{5,00,000}{20\%} \\
 &= 25,00,000
 \end{aligned}$$

$$\begin{aligned}
 \text{(c) Sales} &= \frac{\text{Fixed Cost} + \text{Profit}}{\text{P/V Ratio}} \\
 20,00,000 &= \frac{1,00,000 + \text{Profit}}{20\%} \\
 20,00,000 \times 20\% &= 1,00,000 + \text{Profit} \\
 4,00,000 &= 1,00,000 + \text{Profit} \\
 \therefore \text{Profit} &= 3,00,000
 \end{aligned}$$

Illustration 3:

Year	Sales	Cost
2018	16,20,000	15,76,800
2019	20,52,000	19,22,400

From the above information, calculate: (A) P/V Ratio, (B) Fixed Cost, (C) Break-even Point and (D) Profit/loss when sales 12,96,000.

[M.Com. Modified]

Solution:

Year	Sales	Cost	Profit (Sales – Cost)
2018	16,20,000	15,76,800	43,200
2019	20,52,000	19,22,400	1,29,600

$$\begin{aligned}
 \text{(a) P/V Ratio} &= \frac{\text{Change in Profit}}{\text{Change in Sales}} \times 100 \\
 &= \frac{1,29,600 - 43,200}{20,52,000 - 16,20,000} \times 100 \\
 &= \frac{86,400}{4,32,000} \times 100 \\
 &= 20\% \\
 \text{(b) Fixed Cost} &= \text{Contribution} - \text{Profit} \\
 &= \text{Sales} \times \text{P/V Ratio} - \text{Profit} \\
 &= 16,20,000 \times 20\% - 43,200 \\
 &= 2,80,800 \\
 \text{(c) Break-even Point} &= \frac{\text{Fixed Cost}}{\text{P/V Ratio}} \\
 &= \frac{2,80,800}{20\%} \\
 &= 14,04,000 \\
 \text{(d) Desired Sales} &= \frac{\text{Fixed Cost} + \text{Desired Profit}}{\text{P/V Ratio}}
 \end{aligned}$$

$$\begin{aligned}
 12,96,000 &= \frac{2,80,800 + \text{Profit}}{20\%} \\
 12,96,000 \times 20\% &= 2,80,800 + \text{Profit} \\
 2,59,200 - 2,80,800 &= \text{Profit/Loss} \\
 \therefore \text{Profit/Loss} &= (21,600) \\
 \therefore \text{Loss} &= \text{₹ } 21,600
 \end{aligned}$$

Illustration 4: From the following particulars, you are required to calculate:

1. Profit Volume Ratio;
2. Break-even Point;
3. Profit when sale is ₹ 2,00,000;
4. Sales required to earn a profit of ₹ 40,000;
5. Margin of safety in the 2nd year.

Year	Sales ₹	Profit ₹
I	2,40,000	18,000
II	2,80,000	26,000

You may assume that the cost structure and selling prices remain constant in the two years.

[T.Y.BAF Modified]

Solution:

1. Profit Volume Ratio (PVR) = $\frac{\text{Change in Profit}}{\text{Change in Sales}} \times 100 = \frac{8,000}{40,000} \times 100 = 20\%$
2. Break-even Point (BEP) = $\frac{\text{Fixed Cost}}{\text{P/V Ratio}} = \frac{30,000}{20\%} = \text{₹ } 1,50,000$
3. Profit when sale is ₹ 2,00,000
 Contribution = Sales \times P/V Ratio = 2,00,000 \times 20% = ₹ 40,000
 Profit = Contribution – FC = 40,000 – 30,000 = ₹ 10,000
4. Sales required to earn profit of ₹ 40,000 = $\frac{\text{FC} + \text{Desired Profit}}{\text{PVR}} = \frac{30,000 + 40,000}{20\%} = \text{₹ } 3,50,000$
5. Margin of safety in second year = Actual sales – BE sales = ₹ 2,80,000 – ₹ 1,50,000 = ₹ 1,30,000
6. Contribution = Sales \times P/V Ratio = 2,40,000 \times 20% = ₹ 48,000
7. Fixed Cost (FC) = Contribution – Profit = 48,000 – 18,000 = 30,000

Illustration 5: If sales ₹ 20,00,000, variable cost 15,00,000 and fixed cost 2,00,000, calculate the following:

- (a) Profit Volume Ratio
- (b) Break-even Point
- (c) Sales required to earn profit of ₹ 5,00,000

[T.Y.BAF. Modified]

Solution:

$$\begin{aligned}
 \text{(a) P/V Ratio} &= \frac{\text{Contribution}}{\text{Sales}} \times 100 \\
 &= \frac{\text{Sales} - \text{Variable Cost}}{\text{Sales}} \times 100 \\
 &= \frac{20,00,000 - 15,00,000}{20,00,000} \times 100 \\
 &= \frac{5,00,000}{20,00,000} \times 100 = 25\%
 \end{aligned}$$

$$\begin{aligned}
 \text{(b) Break-even Point} &= \frac{\text{Fixed Cost}}{\text{P/V Ratio}} \\
 &= \frac{2,00,000}{25\%} \\
 &= 8,00,000
 \end{aligned}$$

$$\begin{aligned}
 \text{(c) Sales required to earn profit of ₹ 5,00,000} \\
 \text{Desired Sales} &= \frac{\text{Fixed Cost} + \text{Profit}}{\text{P/V Ratio}} \\
 \therefore \text{Desired Sales} &= \frac{2,00,000 + 5,00,000}{25\%} \\
 &= \frac{2,00,000 + 5,00,000}{25\%} \\
 &= 28,00,000
 \end{aligned}$$

Illustration 6: KT & Co. has prepared the following budget estimates for the year 2018-2019:

Sales 15,000. Selling Price ₹ 10, Variable cost ₹ 6 per unit fixed cost ₹ 34,000

You are required to find:

1. Profit Volume Ratio.
2. Break-even Point.
3. Margin of safety.

Also create revised Profit Volume Ratio, Break-even Point and Margin of Safety, if selling price per unit is reduced by 10%.

[CA Modified]

Solution:

Particulars	Present		Projected	
	Given		Given	
Units (U)	15,000		15,000	
Sale Price (SP)		10		9
Sale (S)		1,50,000		1,35,000
Variable Cost		<u>90,000</u>		<u>90,000</u>
Contribution (S – V)		60,000		45,000

(i) Profit Volume Ratio (PVR) $\frac{\text{Contribution} \times 100}{\text{Sales}}$	$= \frac{60,000}{1,50,000} \times 100$ $= 40.00\%$	$= \frac{45,000}{1,35,000} \times 100$ $= 33.33\%$
(ii) Break-even Point (BEP) (₹) $\frac{\text{Fixed Costs} \times 100}{\text{PVR}}$	$= 85,000$	$= 1,02,000$
(iii) Margin of Safety (₹) $= \text{Actual Sales} - \text{Break-even sales}$	$= 1,50,000 - 85,000$ $= 65,000$	$= 1,35,000 - 1,02,000$ $= 33,000$
(iv) Contribution Per Unit $\text{Contribution} \div \text{Units}$	$60,000 \div 15,000 = 4$	$45,000 \div 15,000 = 3$
(v) Break-even Point (BEP) (Units) $\text{BEP} \div \text{SP}$	$85,000 \div 10 = 8,500$	$1,02,000 \div 9 = 11,333$
(vi) Margin of Safety (Units) $\text{Actual Sales} - \text{Break-even Sales}$	$15,000 - 8,500 = 6,500$	$15,000 - 11,333 = 3,667$

Illustration 7: The following data have been extracted from the books of Alfa Ltd.

Year	Sales ₹	Profit ₹
2018	5,00,000	50,000
2019	7,50,000	1,00,000

You are required to calculate:

- (i) P/V Ratio
- (ii) Fixed Cost
- (iii) Break-even Sales
- (iv) Profit on Sales of ₹ 4,00,000
- (v) Sales to earn of profit of ₹ 1,25,000.

[IPCC Modified]

Solution:

1. P/V Ratio (PVR) $= \frac{\text{Change in Profit}}{\text{Change in Sales}}$
 $= \frac{₹ 1,00,000 - 50,000}{₹ 7,50,000 - 5,00,000} \times 100$
 $= \frac{50,000}{2,50,000} \times 100$
 $= 20\%$
2. Fixed Cost $= \text{Contribution} - \text{Profit}$
 $= \text{(a) } 1,00,000 - 50,000 = ₹ 50,000$
 $\text{(b) } 1,50,000 - 1,00,000 = ₹ 50,000$
- Contribution $= \text{Sales} \times \text{P/V Ratio}$
 $= 5,00,000 \times 20\% = ₹ 1,00,000 \text{ OR}$
 $= 7,50,000 \times 20\% = ₹ 1,50,000$

3. Break-even Sales = $\frac{\text{Fixed Cost}}{\text{P/V Ratio}} = 50,000 \times \frac{100}{20} = ₹ 2,50,000$
4. Profit on Sales of ₹ 4,00,000
 Contribution = Sales × P/V Ratio = 4,00,000 × 20% = ₹ 80,000
 Profit = Contribution – Fixed Cost = 80,000 – 50,000 = ₹ 30,000
5. Sales to earn profit of ₹ 1,25,000
 Required sales = $\frac{\text{Fixed Cost} + \text{Desired Profit}}{\text{P/V Ratio}}$
 = $\frac{50,000 + 1,25,000}{20/100}$
 = $1,75,000 \times \frac{100}{20}$
 = ₹ 8,75,000

Illustration 8: Z Ltd. produces and sells a single article at ₹10 each. The marginal cost of production is ₹ 6 each and fixed cost is ₹ 400 per annum.

Calculate:

1. P/V Ratio
2. The break-even sales (in ₹ and numbers)
3. The sales to earn profit of ₹ 500.
4. Profit at sales of ₹ 3000.
5. New break-even point if sales price is reduced by 10%.
6. Margin of safety at sales of ₹ 1,500.
7. Selling price per unit if the break-even point is reduced to 80 units.

[M.Com. & T.Y.BAF Modified]

Solution:

1. P/V Ratio = $\frac{\text{Contribution}}{\text{Sales}} \times 100 = \frac{4}{10} \times 100 = 40\%$
2. Break-even Sales
 (a) In ₹ = $\frac{\text{Fixed Cost}}{\text{P/V Ratio}} = \frac{400}{40\%} = 400 \times \frac{100}{40} = ₹ 1,000$
 (a) In Nos. = $\frac{\text{Fixed Cost}}{\text{Contribution Per Unit}} = \frac{400}{4} = 100 \text{ units}$
3. Sales to earn profit of ₹ 500 = $\frac{\text{Fixed Cost} + \text{Desired Profit}}{\text{P/V Ratio}}$
 = $\frac{400 + 500}{40\%} = \frac{900}{1} \times \frac{100}{40} = ₹ 2,250$

4. Profit on Sale of ₹ 3000

$$\text{Profit} = \text{Contribution} - \text{Fixed Cost} = 1,200 - 400 = ₹ 800$$

$$\text{Contribution} = 40\% \text{ of } ₹ 3,000 = ₹ 1,200$$

5. New Break-even Point if sales price is reduced by 10%

$$\text{Old Sales Price } ₹ 10$$

$$\text{New Sales Price } 10 - 10\% \text{ of } 10 = 10 - 1 = ₹ 9$$

$$\text{New Contribution} = S - VC = 9 - 6 = 3$$

$$\text{New P/V Ratio} = \frac{\text{Contribution}}{\text{Sales}} \times 100 = \frac{3}{9} \times 100 = 33.33\%$$

$$\text{New BEP (₹)} = \frac{\text{Fixed Cost}}{\text{P/V Ratio}} = \frac{400}{33.33\%} = ₹ 1,200$$

$$\text{New BEP (Units)} = \frac{\text{Fixed Cost}}{\text{Contribution Per Unit}} = \frac{400}{3} = 134(\text{r/o})$$

6. Margin of Safety at Sales ₹ 1,500

$$\begin{aligned} \text{(Old) Margin of Safety} &= \text{Actual Sales} - \text{BEP Sales} \\ &= 1,500 - 1,000 = ₹ 500, \text{ i.e., } 50 \text{ units } (500 \div 10) \end{aligned}$$

$$\text{(New) Margin of Safety} = 1,500 - 1,200 = ₹ 300, \text{ i.e., } 34 \text{ units } (300 \div 9; \text{ r/o})$$

7. Selling Price per unit if BEP is reduced to 80 units

$$\text{Break-even Point in units} = \frac{\text{Fixed Cost}}{\text{Contribution per unit}}$$

$$80 = \frac{400}{\text{Contribution per unit}}$$

$$\text{Contribution per unit} = \frac{400}{80} = ₹ 5$$

$$\begin{aligned} \text{Selling Price per unit} &= \text{Contribution Per Unit} + \text{Variable Cost per unit} \\ &= 5 + 6 = ₹ 11 \text{ per unit} \end{aligned}$$

Illustration 9: A product is sold at ₹ 80 per unit. Its variable cost is ₹ 60 and fixed cost is ₹ 6,00,000. Compute the following:

1. P/V Ratio
2. Break-even Point
3. Margin of safety at a sale of 50,000 units.
4. At what sale, the producer will earn profit at 15% on sales?

[M.Com. Modified]

Solution:

	₹
Sale	80.00
Variable Cost	60.00
Contribution	20.00

1. P/V Ratio = $\frac{\text{Contribution}}{\text{Sales}} \times 100 = \frac{20}{80} \times 100 = 25\%$
2. Break-even Point = $\frac{\text{Fixed Cost}}{\text{P/V Ratio}} = \frac{6,00,000}{25\%} = ₹ 24,00,000$
3. Margin of Safety (MOS) at a Sale of 50,000 Units
- BEP Units = $\frac{\text{BEP (₹)}}{\text{Sale Price}} = \frac{24,00,000}{80} = 30,000$
- MOS = Sale Units – BEP Units
= 50,000 – 30,000 = 20,000 Units
4. Sale to earn a profit of 15% on sale
- Sales = ₹ 80 per unit
- Variable Cost = ₹ 60 per unit
- Profit = $15 \times 80 \div 100 = 12$ per unit
- Fixed Cost = ₹ 6,00,000

Let units sold be x

Sale = $80 \times x$; since Sales = Variable Cost + Fixed Cost + Profit

$$\text{Therefore, } 80X = 60X + 6,00,000 + 12X$$

$$80X = 72X + 6,00,000$$

$$8X = 6,00,000$$

$$X = 6,00,000 \div 8$$

$$X = 75,000 \text{ units}$$

Illustration 10: From the following data, compute:

- P/V Ratio
- BEP in rupees and unit.
- Number of units to be sold to earn a profit of ₹ 7,50,000.

Sales Price	₹ 20 per unit
Direct Material	₹ 5 per unit
Direct Wages	₹ 6 per unit
Variable Administration Overheads	₹ 3 per unit
Fixed Factory Overheads	₹ 6,40,000 per year
Fixed Administration Overhead	₹ 1,52,000 per year

[M.Phil.Modified]

Solution:

Sale per Unit	= ₹ 20
Variable Cost Per Unit	= Direct Expenses + Variable Expenses = 5 + 6 + 3 = ₹ 14
Contribution Per Unit	= Sale – Variable Cost = 20 – 14 = ₹ 6

$$\begin{aligned} \text{Fixed Cost} &= \text{Factory Overhead} + \text{Administrative Overhead} \\ &= 6,40,000 + 1,52,000 = ₹ 7,92,000 \\ 1. \text{ Profit Volume Ratio (PVR)} &= \frac{\text{Contribution}}{\text{Sales}} \times 100 = \frac{6}{20} \times 100 = 30\% \\ 2. \text{ Break-even Point (BEP)} &= \frac{\text{Fixed cost}}{\text{Profit Volume Ratio}} = \frac{7,92,000}{30\%} = ₹ 26,40,000 \\ 3. \text{ BEP (Units)} &= \frac{\text{Break - even Point}}{\text{Sales Price}} = \frac{26,40,000}{20} = ₹ 1,32,000 \\ 4. \text{ Number of units to be sold to earn profit of ₹ 7,50,000} &= \frac{\text{Fixed Cost} + \text{Profit}}{\text{Contribution per unit}} \\ &= \frac{7,92,000 + 7,50,000}{6} = 2,57,000 \end{aligned}$$

Illustration 11: The XL Ltd. furnish the following information:

	Ist Period	IInd Period
Sales	20,00,000	30,00,000
Profit	2,00,000	4,00,000

You are required to calculate:

1. P/V Ratio
2. Fixed Expenses
3. BEP
4. Sales to earn profit ₹ 5,00,000
5. Profit when sales are ₹ 15,00,000

[IPCC Modified]

Solution:

$$\begin{aligned} 1. \text{ P/V Ratio} &= \frac{\text{Change in Profit}}{\text{Change in Sales}} \times 100 = \frac{2,00,000}{10,00,000} \times 100 = 20\% \\ 2. \text{ Fixed Expenses} &= \text{Contribution} - \text{Profit} = 4,00,000 - 2,00,000 = ₹ 2,00,000 \\ \text{Contribution} &= \text{Sales} \times \text{P/V Ratio} = 20,00,000 \times 20\% = 4,00,000 \\ 3. \text{ Break-even Point (in ₹)} &= \frac{\text{Fixed Cost}}{\text{P/V Ratio}} \times 100 = \frac{2,00,000}{20} \times 100 = ₹ 10,00,000 \end{aligned}$$

Sales to earn profit of ₹ 5,00,000

$$\begin{aligned} \text{Desired Contribution} &= \text{Fixed Cost} + \text{Required Profit} \\ &= 2,00,000 + 5,00,000 = ₹ 7,00,000 \end{aligned}$$

$$\text{Required Sales} = \frac{\text{Desired Contribution}}{\text{P/V Ratio}} \times 100 = \frac{7,00,000}{20} \times 100 = ₹ 35,00,000$$

4. Profit when sales are ₹ 15,00,000

$$\text{Desired Contribution} = \text{Sales} \times \text{P/V Ratio} = 15,00,000 \times 20\% = ₹ 3,00,000$$

$$\text{Desired Profit} = \text{Desired Contribution} - \text{Fixed Cost}$$

$$= 3,00,000 - 2,00,000$$

$$= ₹ 1,00,000$$

Illustration 12: Following particulars are available for A Ltd. and B Ltd.:

Particulars	A Ltd.	B Ltd.
Sales	₹ 6,00,000	₹ 6,00,000
P/V Ratio	25%	20%
Fixed Cost	₹ 90,000	₹ 80,000

Calculate for each company:

- (i) Break-even Point
- (ii) Margin of Safety
- (iii) Sales required to earn profit of ₹ 90,000

[CA Modified]

Solution:

Particulars	A Ltd.	B Ltd.
(a) Break-even Point = $\frac{\text{Fixed Cost}}{\text{P/V Ratio}}$	$\frac{90,000}{25\%}$ = ₹ 3,60,000	$\frac{80,000}{20\%}$ = ₹ 4,00,000
(b) Margin of Safety = Actual Sales – Break-even Sales	6,00,000 – 3,60,000 = ₹ 2,40,000	6,00,000 – 4,00,000 = ₹ 2,00,000
(c) Sales required to earn profit ₹ 90,000 = $\frac{\text{Fixed Cost} + \text{Desired Profit}}{\text{P/V Ratio}}$	$\frac{90,000 + 90,000}{25\%}$ = ₹ 7,20,000	$\frac{80,000 + 90,000}{20\%}$ = ₹ 8,50,000

Illustration 13: M/s EAR Enterprises furnishes the following information:

Year	Sales (₹)	Profit (₹)
2018	6,00,000	60,000
2019	8,00,000	1,00,000

From the above, calculate the following information:

- (i) P/V Ratio
- (ii) Fixed Cost
- (iii) Break-even Cost
- (iv) Sales to earn profit ₹ 2,00,000
- (v) Margin of Safety of 2019.

[T.Y.BAF Modified]

Solution:

$$\begin{aligned}
 1. \text{ P/V Ratio} &= \frac{\text{Change in Profit}}{\text{Change in Sales}} \times 100 \\
 &= \frac{1,00,000 - 60,000}{8,00,000 - 6,00,000} \times 100 \\
 &= 20\% \\
 2. \text{ Fixed Cost} &= \text{Contribution} - \text{Profit} \\
 &= (\text{P/V Ratio} \times \text{Sales}) - \text{Profit} \\
 &= (20\% \times 6,00,000) - 60,000 = ₹ 60,000 \\
 &= 20\% \times 8,00,000 - 1,00,000 = ₹ 60,000 \\
 3. \text{ Break-even Sales} &= \frac{\text{Fixed Cost}}{\text{P/V Ratio}} = \frac{₹ 60,000}{20\%} = ₹ 3,00,000 \\
 4. \text{ Sales to Earn Profit ₹ 2,00,000} &= \text{Desired Sales} = \frac{\text{Desired Contribution}}{\text{P/V Ratio}} \\
 \text{Desired Contribution} &= \text{Fixed Cost} + \text{Desired Profit} \\
 &= 60,000 + 2,00,000 = 2,60,000 \\
 \text{Desired Sales} &= \frac{2,60,000}{20\%} = ₹ 13,00,000 \\
 5. \text{ Margin of Safety for 2019} \\
 \text{MOS Sales} &= \text{Total Sales} - \text{Break-even Sales} \\
 &= 8,00,000 - 3,00,000 = ₹ 5,00,000 \\
 \text{MOS Margin} &= \frac{\text{MOS Sales}}{\text{Total Sales}} \times 100 \\
 &= \frac{5,00,000}{8,00,000} \times 100 \\
 &= 62.5\%
 \end{aligned}$$

Illustration 14: From the following particulars, you are required to calculate:

- (i) Fixed Cost
- (ii) Profit Volume Ratio
- (iii) Break-even Sales

Particulars	2018 (₹)	2019 (₹)
Total Cost	12,96,000	18,72,000
Sales	14,40,000	21,60,000

[M.Com. Modified]

Solution:

$$\text{Profit (1st Period)} = 14,40,000 - 12,96,000 = 1,44,000$$

$$\text{Profit (2nd Period)} = 21,60,000 - 18,72,000 = 2,88,000$$

$$\begin{aligned}
 \text{(a) P/V Ratio} &= \frac{\text{Change in Profit}}{\text{Change Sales}} \times 100 \\
 &= \frac{(2,88,000 - 1,44,000)}{(21,60,000 - 14,40,000)} \times 100 \\
 &= \frac{1,44,000}{7,20,000} \times 100 = 20\% \\
 \text{(b) Fixed Cost (2012)} &= \text{Contribution} - \text{Profit} \\
 &= (\text{P/V Ratio} \times \text{Sales}) - \text{Profit} \\
 &= (\text{₹ } 14,40,000 \times 20\%) - 1,44,000 \\
 &= \text{₹ } 2,88,000 - \text{₹ } 1,44,000 = \text{₹ } 1,44,000 \\
 \text{(c) Break-even Sales} &= \frac{\text{Fixed Cost}}{\text{PV Ratio}} = \frac{1,44,000}{20\%} = \text{₹ } 7,20,000
 \end{aligned}$$

Illustration 15: The following is the cost structure of a product Selling price ₹ 100 per unit.

Variable cost per unit:

Material	₹ 38
Labour	₹ 14
Direct Expenses	₹ 8

Fixed overheads for the year:

Factory Overheads	₹ 2,80,000
Office Overheads	₹ 2,20,000
No. of Units Produced and Sold	₹ 40,000

Calculate:

1. P/V Ratio
2. Break-even Point in units
3. Margin of Safety Amount
4. Break-even Point if fixed overheads increased by 20%.
5. Revised P/V Ratio when selling price increased by 20%.

[M.Com. & TYBAF Modified]

Solution:

Particulars	Total ₹	Per Unit ₹
(A) Sales	40,00,000	100
(B) Variable Cost		
– Material	15,20,000	38
– Labour	5,60,000	14
– Expenses	3,20,000	8
Subtotal	24,00,000	60

(C) Contribution (A – B)	16,00,000	40
(D) Fixed Cost			
Factory	2,80,000	
Office	2,20,000	
Subtotal	5,00,000	
(E) Profit (C – D)	11,00,000	

1. P/V Ratio = $\frac{\text{Contribution}}{\text{Sales}} = \frac{40}{100} = 40\%$
2. Break-even Point in Units = $\frac{\text{Fixed Cost}}{\text{Contribution per Unit}} = \frac{5,00,000}{40} = 12,500 \text{ Units}$
3. Margin of Safety Amount = Units = $40,000 - 12,500 = 27,500 \text{ Units}$
= Amount = $40,00,000 - 12,50,000 = 27,50,000$
4. Break-even Point is fixed overheads increased by 20%

Contribution	=	16,00,000
New Fixed Overheads	=	6,00,000
Profit	=	10,00,000
Break-even Point in Units	=	$\frac{\text{Fixed Cost}}{\text{Contribution per Unit}} = \frac{6,00,000}{40} = 15,000 \text{ units}$
Break-even Point in ₹	=	15,00,000
5. Selling Price increased by 20% = P/V Ratio = $\frac{\text{Sales} - \text{Variable Cost}}{\text{Sales}} = \frac{120 - 60}{120} = 50\%$

Illustration 16: A company produces and sells 1,500 units of a commodity at ₹ 20 each. The variable cost of the production is ₹ 12 per unit and fixed cost ₹ 8,000 per annum.

Calculate:

- (i) P/V Ratio
- (ii) Sales at break-even point
- (iii) Additional sales required to earn the same amount of profit if selling price is reduced by 10%.

[M.Phil. Modified]

Solution:

Particulars	Original (1500 units)		Working Revised	
	Sales per Unit [S]	20	30,000	20 – 10%
Variable Cost per Unit [V]	12	18,000	12	
Contribution per Unit [S – V]	8	12,000		6
Fixed Costs (FC)		8,000		8,000
Profit		4,000		

Equations:

$$(i) \text{ Profit Volume Ratio (PVR)} = \frac{\text{Contribution}}{\text{Sales}} \times 100 = \frac{C}{S} \times 100 = \frac{12,000}{30,000} \times 100 = 40\%$$

$$(ii) \text{ Break-even Point in Units} = \frac{\text{Fixed Cost}}{\text{Profit Volume Ratio}} = \frac{8,000}{40\%} = ₹ 20,000$$

$$\text{BEP (Units)} = \frac{\text{Break - even Point}}{\text{Sale Price}} = \frac{20,000}{20} = 1000 \text{ units}$$

$$(iii) \text{ Number of units to be sold to earn same profit of ₹ 4,000} = \frac{\text{Fixed cost} + \text{Profit}}{\text{Contribution per unit}}$$

$$= \frac{8,000 + 4,000}{6}$$

$$= 2,000$$

Units sold earlier = 1,500

Additional units to be sold = 2,000 – 1,500 = 500

Exercise

1. You are given the following information for the next year.

Sales (10,000 units)	₹ 1,20,000
Variable cost	₹ 48,000
Fixed cost	₹ 60,000

Find out the P/V ratio, Break-even point and the margin of safety.

Ans.: 60%, 1,00,000, 20,000

2. Products

Particulars	X	Y	Z
Units	10,000	15,000	20,000
Selling price	4	4	4
Variable cost	2.5	3	3.5
Fixed cost	12,000	9,000	7,500

Find Profit, Break-even point and Margin of safety of each product as well as that of the company.

Ans.:

	X	Y	Z
Profit	3,000	6,000	2,500
Break-even point	32,000	36,000	60,000
Margin of safety	8,000	24,000	20,000

3. KT & Co. has prepared the following budget estimated for the year 2018-19: sales 15,000 units, sales value ₹ 1,50,000, fixed expenses ₹ 34,000 and variable per unit ₹ 6/-.

You are required to find: (i) Profit Volume Ratio, (ii) Break-even Point and (iii) Margin of safety.

Also calculate revised Profit Volume Ratio, Break-even Point and Margin of Safety, if selling price per unit is reduced by 10%.

Ans.: Profit Volume Ratio 40% (Actual) and 33.33% (After Redemption),
Break-even point 85,000 (Actual) and 1,02,000 (After Redemption),
Margin of safety 65,000 (Actual) and 33,000 (After Redemption)

4.

Period	I	II
Sales (₹ lakhs)	150	200
Profit (₹ lakhs)	30	50

Find P/V Ratio, Fixed Cost, Break-even Point; Sales to earn profit of ₹ 90 lakhs and Profit at sales of ₹ 280 lakhs.

Ans.: Profit Volume Ratio 40%, Fixed Cost 30,00,000, Break-even point 1,20,00,000,
D.S 3,00,00,000, D. P 82,00,000

5. From the following particulars, you are required to calculate: (i) Profit volume ratio, (ii) Break-even point, (iii) Profit when sale is ₹ 2,00,000, (iv) Sales required to earn profit of ₹ 40,000 and (v) Margin of safety in the year 2nd year.

Year	Sales ₹	Profit ₹
I	2,40,000	18,000
II	2,80,000	26,000

Ans.: Profit Volume Ratio 20%, Break-even point 1,50,000, D.P 10,000, D.S 3,50,000,
MOS 1,30,000

6. EXE Ltd. manufactures and sells four types of products A, B, C and D. The sales mix in value comprises of $33\frac{1}{3}\%$, $41\frac{2}{3}\%$, $16\frac{2}{3}\%$ and $8\frac{1}{3}\%$ of products A, B, C and D respectively.

The total budgeted sales (100 per cent) are ₹ 60,000 per month.

Operations costs are:

Variable costs:

Product A	60% of selling price
Product B	68% of selling price
Product C	80% of selling price
Product D	40% of selling price
Fixed cost	₹ 14,700 of selling price

Calculate the break-even point for the products on an overall basis. It is proposed to change the sales mix as follows:

Product A	25%
Product B	40%
Product C	30%
Product D	5%

The total sales per month at ₹ 60,000. If this proposal is implemented, what will be the break-even point?

Ans.: ₹ 46,226

7. Jayashree Enterprises present the following information to you relating to the half year ended 30-6-2020:

Fixed Expenses	:	₹	45,000
Sales	:	₹	1,45,000
Profit	:	₹	30,000

During the second half year of 2020, the company had projected a loss of ₹ 10,000. You are required to calculate:

- The break-even point and margin of safety for the six months ended 30.6.2020.
- Expected sales in the second half year assuming that P/V ratio and fixed expenses remain constant in the second half year also.
- The break-even point and margin of safety for the whole of 2020.

Ans.: 87,000, 67,667, 1,74,000

8. A customer produces and sells 100 units of A per month at ₹ 20. Marginal cost per unit is ₹ 12.00 and fixed costs are ₹ 300 per month. It is proposed to reduce the selling price by 20%. Find the additional sales required to earn the same profit as before.

Ans.: 400

Objective Questions

I. Fill in the Blanks

- Elements of costs are classified into _____ and _____.
- Fixed Cost is treated as _____ and charged to P & L account
- _____ costs are treated as product cost.
- The _____ shows the relationship among unit sale price, variable cost, sales volume, sales mix and fixed cost.
- Fixed cost remains constant _____.
- Those activities that results in cost are known as _____.
- Variable cost is fixed _____ but varies in _____.
- Contribution is also known as contribution margin or _____.
- Fixed cost – Loss = _____.

[**Ans.:** 1. Variable cost, fixed cost, 2. Period cost, 3. Variable, 4. CVP analysis, 5. In total, 6. Cost drivers, 7. Per unit, total, 8. Gross margin, 9. Contribution.]



MANAGERIAL DECISION MAKING

The marginal costing helps the management in taking many policy decisions. The vital areas where these concepts are applied directly are as follows:

- 1. Level of activity planning:** Normally, the managements will consider different levels of production or selling activities to decide optimum level of activity. Such periodic exercise shall put the organisation in the right track to achieve its goal. Since the optimum level of activity results in the maximum contribution per unit, the planning can become a perfect execution tool.
- 2. Alternative methods of production:** With the help of marginal costing techniques, it is possible to undertake decision about the alternate methods of production. All the decisions should be focused at the greater contribution so that profit can be maintained at a balanced level.
- 3. Make or buy decision:** Depending upon the situational ambience, the management can have a blueprint on a vital decision. Management can think of outsourcing the production activities or to undertake it within its purview. Based on the comparative statement of cost of manufacture with the purchase price, decisions can be taken.
- 4. Fixation of selling price:** While pricing a product, the marginal costing techniques can come handy. While fixing a price for a product, it is prudent to take into account the recovery of marginal cost in addition to get a reasonable contribution to cover fixed overheads. Pricing will be at ease once the marginal cost and overall profitability of the concern are known.
- 5. Selection of optimum sales mix:** The product mix plays an important role when a firm produces more than one product. The main focus will on profit maximisation. With the help of marginal costing techniques, it is possible to decide the best product mix which will result in maximum profits to the firm.
- 6. New product introduction:** When a firm intends to diversify its activities or to expand its existing markets with the help of marginal costing techniques, by fixing the time horizon to recover the fixed costs and profit, decisions can be taken for the introduction of new products.
- 7. Balancing of profits:** As the economic trends gets changed on account of government fiscal policies and regulations, competition at the regional, national, and international levels, marginal costing techniques can aid to bring out facts with regard to maintaining a desired level of profits.
- 8. Final balancing decisions:** If the sales of the product were not encouraging to cover the fixed costs, it is quite natural that the firm may decide about its continuance. This may lead to dovetailing or completely closing down the operations. Marginal costing helps the management to take a sound decision.

Decision-making

Decision-making is the process of evaluating two or more alternatives leading to a final choice known as alternative choice decisions. Decision-making is closely associated with planning for the future and is directed towards a specific objective or goal. Decision model contains the following decision-making steps or elements:

1. Identify and define the problem.
2. Identify alternative as possible solutions to the problem.
3. Eliminate alternatives that are clearly not feasible.
4. Collect relevant data (costs and benefits) associated with each feasible alternative.
5. Identify cost and benefits as relevant or irrelevant and eliminate irrelevant costs and benefits from consideration.
6. Identify to the extent possible, non-financial advantages and disadvantages about each feasible alternative.
7. Total the relevant cost and benefits for each alternative.
8. Select the alternative with the greatest overall benefits to make a decision.
9. Implement or execute the decision.
10. Evaluate the results of the decision made.

Types of Costs

A decision involves selecting among various choices. Non-routine types of decisions are crucial and critical to the firm as it involves huge investments and involve much uncertainty. Short-term decision-making is based on relevant data obtained from accounting information.

Relevant cost are costs which would change as a result of the decision.

Opportunity costs are monetary benefits foregone for not pursuing the alternative course. When a decision to follow one course of action is made, the opportunity to pursue some other course is foregone.

Sunk costs are historical cost that cannot be recovered in a given situation. These costs are irrelevant in decision-making.

Avoidable costs are costs that can be avoided in future as a result of managerial choice. It is also known as discretionary costs. These costs are relevant in decision-making.

Incremental/differential costs are costs that include variable costs and additional fixed costs resulting from a particular decision. They are helpful in finding out the profitability of increased output and give a better measure than the average cost.

Types of Choices Decisions

The application of incremental/differential costs and revenues for decision-making is known as decision situations or types of choice decisions.

1. Make or buy decisions
2. Addition or discontinuance of a product line or process
3. Sells or process further, etc.

Make or Buy Decisions: Make or buy decisions arise when a company with unused production capacity consider the following alternatives:

- (a) To buy certain raw materials or subassemblies from outside suppliers.
- (b) To use available capacity to produce the items within the company.
- (c) The quality and type of item which affects the production schedule.
- (d) The space required for the production of item.
- (e) Any transportation involved due to the location of production facility.
- (f) Cost of acquiring special know-how required for the item.

Addition or Discontinuance of a Product Line or Process: The decision to add or eliminate an unprofitable product is a special case of product profitability evaluation. When a firm is divided into multiple sales outlets, product lines, divisions and departments, it may have to evaluate their individual performance to decide whether or not to continue operations of each of these segments.

Sells or Process Further: A firm is frequently faced with the problem of continuing with the existing policies or plans or change to new ones. Such change could be in the form of selling a partially processed product (semi-finished) or process further. While taking a decision about such matters, the management must keep in mind the long-term consequence and the interest of the firm.

Illustrations

(Determination of Profitable Sale Mix)

Illustration 1: From the following information, you are required to:

- (a) Calculate and present the marginal product costs and contribution per unit
- (b) State which of the alternative sales mixes you would recommend to management? Why?

Particulars	Per Unit (₹)
Selling Price:	
For X	250
For Y	200
Direct Materials:	
For X	80
For Y	60
Direct Wages:	
For X	60
For Y	40

Fixed overheads are 75,000 and variable overheads are 150% of direct wages. Alternative Sales Mix:

1. 2500 units of Product X and 2500 units of Product Y.
2. Nil units of Product X and 4000 units of Product Y.
3. 4000 units of Product X and 1000 units of Product Y.

[CS Modified]

Solution:**Statement Showing Marginal Cost and Contribution per unit**

Particulars	Product X		Product Y	
	₹	₹	₹	₹
Selling Price		250		200
<i>Less: Marginal Cost</i>				
Direct Materials	80		60	
Direct Wages	60		40	
Variable Overheads	90	230	60	160
Contribution		20		40

Statement Showing Profitability of Alternative Sales Mix

Particulars	X	Y	Total	X	Y	Total	X	Y	Total
Sales Mix (units)	2,500	2,500	5,000	Nil	4,000	4,000	4,000	1,000	5,000
Contribution	50,000	1,00,000	1,50,000		1,60,000	1,60,000	80,000	40,000	1,20,000
<i>Less: Fixed Overheads</i>			75,000			75,000			75,000
Profit			75,000			85,000			45,000

4,000 units of y should be sold as it gives higher profit.

Illustration 2: Following information has been made available from the cost records of the company manufacturing spare parts:

Direct Materials	Per Unit
A	₹ 8
B	₹ 6

Direct Wages	
A	4 hours at ₹ 2 per hour
B	6 hours at ₹ 2 per hour
Variable Overheads	150% of wages
Fixed Overheads	₹ 750
Selling Price of A	₹ 30
Selling Price of B	₹ 35

The directors want to be acquainted with the desirability of adopting any one of the following alternative sales mixes in the budget for the next period:

- 250 units of A and 250 units of B
- 400 units of B only.
- 400 units of A and 100 units of B
- 150 units of A and 350 units of B

State which of the alternative sales mixes you should recommend to the management.

[CS & Modified]

Solution:

Statement of Contribution (per unit)

Particulars	A	B
Selling Price	30	35
(-)Variable Expenses:		
Direct Material	8	6
Direct Wages	8	12
Variable Overheads	12	18
Contribution	2	(1)

Particulars	(a)	(b)	(c)	(d)
	250 units of A and 250 units of B (₹)	400 units of B only (₹)	400 units of A and 100 units of B (₹)	150 units of A and 350 units of B (₹)
Contribution of A	500	-	800	300
Contribution of B	-250	-400	-100	-350
Total Contribution	250	(400)	700	(50)
Less: Fixed Overhead	750	750	750	750
Profit/Loss	(500)	(1,150)	(50)	(800)

Conclusion: Alternative (C) with 400 units of A and 100 units of B is recommended to the management, as the loss is minimum.

Illustration 3: From the following data, you are required to present:

- (i) The marginal cost of product of X and Y and the contribution per unit.
- (ii) The total contribution and profit resulting from each of the suggested sales mixtures.

Particulars	Product	Per Unit ₹
Direct Materials	x	10.5
Direct Materials	y	8.5
Direct Wages	x	3
Direct Wages	y	2

Variable expenses 100% of direct wages per product.

Fixed Expenses (total) ₹ 800

Sales Price X ₹ 20.50

Y ₹ 14.50

Suggested Sales Mixes

Alternatives	No. of X	Results Y
A	100	200
B	150	150
C	200	100

[M.Com. & T.Y.BAF Modified]

Solution:**Evaluation of Sales Mix**

Particulars	Product X ₹	Product Y ₹
Direct Materials	10.5	8.5
Direct Wages	3	2
Variable Expenses (100% of Direct wages)	3	2
Marginal Cost per unit	16.5	12.5
Selling Price per unit	20.5	14.5
Less: Marginal Cost	16.5	12.5
Contribution per unit	4	2

Sales Mix A

Particulars	₹
Contribution from 100 units of Product X at ₹ 4	400
Contribution from 200 units of Product Y at ₹ 2	400
Total Contribution	800
Less: Fixed Expenses	800
Profit (₹)	Nil

Sales Mix B

Particulars	₹
Contribution from 150 products X at ₹ 4	600
Contribution from 150 Products Y at ₹ 2	300
Total Contribution	900
Less: Fixed Expenses	800
Profit	100

Sales Mix C

Particulars	₹
Contribution from 200 products X at ₹ 4	800
Contribution from 100 products Y at ₹ 2	200

Total Contribution	1,000
Less: Fixed Expenses	800
Profit	200

Advice: Mix C should be adopted because it gives maximum contribution and profit.

Illustration 4: The following information in respect of product X and Y of ABC Co. Ltd is obtained.

Particulars	Products	
	X	Y
Sale Price	1000	640
Direct Material	400	400
Direct Labour Hours (@ ₹ 5 per hour)	20 hours	40 hours
Variable Overheads	100% of Direct Wages	100% of Direct Wages

Fixed Overheads are ₹ 30,000.

You are required to:

- Calculate and present the marginal product costs and contribution per unit
- State which of the following alternative mixes you would recommend? Why?
- 100 units of Product X and 50 units of Product Y
- 50 units of Product X and 100 units of Product Y
- 150 units of Product X only
- 150 units of Product Y only

[M.Com. Modified]

Solution:

Marginal Cost Statement

Particulars	Products	
	X	Y
Sales Price (A)	1000	640
Variable Cost:		
Direct Material	400	400
Direct Labour at ₹ % per hour	100	200
Variable Overhead (100% of Wages)	100	200
Marginal Cost (B)	600	800
Marginal Contribution per Unit = (A) – (B)	400	(160)
Case 1: 100 Units of Product X and 50 of Product Y		40,000
Contribution from 100 Units of x = 100 × 400		
Cont. from 50 Units of Y = 50 × 160		(8,000)

Total Contribution	32,000
Less: Fixed Cost	30,000
Profit	2,000
Case 2: 50 Units of Product X and 100 of Product Y	
50 Units of X = 50×400	20,000
100 Units of Y = 100×160	(16,000)
Total Contribution	4,000
Less: Fixed Cost	30,000
Loss	(26,000)
Case 3: 150 Units of Product X only	
150 Units \times 400	60,000
Less: Fixed Cost	30,000
Profit	30,000
Case 4: 150 Units of Product Y only	
Contribution = $150 \text{ Units} \times 160$	(24,000)
Less: Fixed Cost	30,000
Loss	(54,000)

Hence, Case 3 is the most profitable case, i.e., 150 units of Product X only is suitable.

Illustration 5: Following information is available:

Particulars	Product A (Per Unit) (₹)	Product B (Per Unit) (₹)
Direct Materials	100	120
Direct Wages	120	80
Variable Overheads	180	120
Selling Price	500	400

Fixed Overheads ₹ 15,000.

From the following alternatives, which sales mixes will bring higher profits.

- 250 units of A and 250 units of B
- 400 units of A and 100 units of B
- 150 units of A and 350 units of B
- 400 units of B.

Support the answer with workings.

[M.Com. & T.Y.BAF Modified]

Solution:

Statement of Contribution per Unit

Particulars	Product A (₹)	Product B (₹)
Direct Materials	100	120
Direct Wages	120	80
Variable Overheads	180	120
Total Variable Cost (b)	400	320
Selling Price (a)	500	400
Contribution (a-b)	100	80

Particulars	Option (a) 250 of A and 250 of B	Option (b) 400 of A and 100 of B	Option (c) 150 of A and 350 of B	Option (d) 400 of B
Units Produced and Sold	(250 × 100) + (250 × 80)	(400 × 100) + (100 × 80)	(150 × 100) + (350 × 80)	(400 × 80)
Contribution	45,000	48,000	43,000	32,000
Less: Fixed Cost	15,000	15,000	15,000	15,000
Profit	30,000	33,000	28,000	17,000

Option (b) will result into higher profit.

(At Different Level of Production)

Illustration 6: A manufacturing company is operating at 75% of its full capacity. It is proposed to offer a price reduction of 5% to 10% depending upon volume desired. Given below are the relevant data:

Capacity	75	85	100
Output (Units)	75,000	85,000	1,00,00
Selling Price per Unit	₹ 96	5% off	10% off
Material Cost Per Unit	₹ 40	10% less	15% less
Wages Cost Per Unit	₹ 10	₹ 10	₹ 10

Fixed Overheads:

Production ₹ 14,00,000

Selling and Administration ₹ 5,00,000

Variable Overheads (at full capacity):

Selling and Administration 4,40,000

Production 14,00,000

- Prepare a statement showing variable cost, fixed cost, total cost and profit/loss in terms of ₹ and per unit at 75%, 85% and 100% capacity.
- Indicate which of the three levels is most profitable.

[IPCC Modified]

Solutions:

Capacity	75% 75,000		85% 85,000		100% 1,00,000	
		Amt		Amt		Amt
Sales	96	72,00,000	91.20	77,52,000	86.40	86,40,000
Less: Variable Costs:						
Material	40	30,00,000	36	30,60,000	34	34,00,000
Wages	10	7,50,000	10	8,50,000	10	10,00,000
Variable Production Overhead	14	10,50,000	14	11,90,000	14	14,00,000
Variable Selling and Administration Overhead	4.40	3,30,000	4.40	3,74,000	4.40	4,40,000
Total Variable Cost	68.4	51,30,000	64.4	54,74,000	62.40	62,40,000
Contribution	27.6	20,70,000	26.8	22,78,000	24.00	24,00,000
Fixed Overheads:						
Production	18.67	14,00,000	16.47	14,00,000	14	14,00,000
Selling and Administration	6.67	5,00,000	5.88	5,00,000	5	5,00,000
Profit	2.27	1,70,000	4.44	3,78,000	5	5,00,000

Recommendation: Operating at 100% i at full capacity is most profitable.

Illustration 7: A factory engaged in manufacturing plastic buckets is working at 40% capacity and produces 10000 buckets per month. The present cost break-up is as under:

Material	₹ 20
Labour	₹ 6
Overheads	₹ 10 (60% fixed)

The selling price is ₹ 40/- per bucket. If it is decided to work the factory at 50% capacity, the selling price falls by 3% and at 90% capacity by 5% accompanied by a similar fall in the price of materials.

You are required to prepare a statement showing the profit of 50% and 90% capacities and also determine the break-even point at each of these production levels.

[T.Y.BAF & M.Com. Modified]

Solution:**Statement Showing profit and BEP at Different Level of Capacity**

Particulars	Existing	50% capacity 12500 units		90% Capacity 22500 Units	
	P.U. ₹	P.U. ₹	Total ₹	P.U. ₹	Total ₹
Sales (A)	40	38.80	4,85,000	38.00	8,55,000
Less: Variable Cost:					
Materials	20	19.40	2,42,500	19.00	4,27,500
Labour	6	6.00	75,000	6.00	1,35,000
Overhead (Variance)	4	4.00	50,000	4.00	90,000
(B)	30	29.40	3,67,500	29.00	6,52,500

Contribution (A – B)	10.00	9.40	1,17,500	9.00	2,02,500
Less: Fixed Cost			60,000		60,000
			57,500		1,42,500

At 40% Fixed Cost = 6*10,000 = ₹ 60,000

At 50%	At 90%
BEP = Fixed Cost* Selling Price/Units/ Contribution/Units	BEP = Fixed Cost* Selling Price/Units/ Contribution/Units
= 60000 * 38.80/9.40	= 60000 * 38/9
= ₹ 2,47,660	= ₹ 2,53,333
Or	Or
= 6,383 buckets	= 6,667 buckets

(Determination of the Product to be Pushed)

Illustration 8: The following data are expected from the annual planning budget.

Particulars	Product A	Product B	Product C	Total
	(₹)	(₹)	(₹)	(₹)
Sales :				
5,000 units @ ₹ 2 each	10,000	–	–	–
10,000 units @ ₹ 6 each	–	60,000	–	1,50,000
20,000 units @ ₹ 4 each	–	–	80,000	–
Cost:				
Fixed	1,000	13,500	12,000	26,500
Variable	3,000	12,000	48,000	63,000
Total	4,000	25,500	60,000	89,500
Net Profit	6,000	34,500	20,000	60,500

You are required to compute break-even points for each product and the company’s break-even points assuming a constant sales mix quantity ratio of 1:2:4, based on the data given, what product should be pushed and why? Also compute the company’s break-even points assuming a constant sales mix as follows:

Case I: Product A 10,000 units and product B 10,000, Product C 15,000 units.

Case II: Product A 5,000 units and product B 15,000, Product C 10,000 units.

[M.Com. Modified]

Solution:

Contribution to Break-even Point

Particulars	Product A	Product B	Product C	Product D
Sales	10,000	60,000	80,000	1,50,000
Less: Variable Cost	3,000	12,000	48,000	63,000
Contribution	7,000	48,000	32,000	87,000

Less: Fixed Cost	1,000	13,500	12,000	26,500
Profit	6,000	34,500	20,000	60,500
P/V Ratio = C/S × 100	$\frac{7,000}{10,000} \times 100$	$\frac{48,000}{60,000} \times 100$	$\frac{32,000}{80,000} \times 100$	$\frac{87,000}{1,50,000} \times 100$
BEP = FC/P/V Ratio	$1,000/70\%$ = ₹ 1429	$13,500/80\%$ = ₹ 16875	$12,000/40\%$ = ₹ 30,000	$26,500/58\%$ = ₹ 45,690

∴ Company should push up product B as the P/V ratio is highest.

Case I (Product A 10,000, Product B 10,000 and Product C 15,000 units)

Particulars	A	B	C	Total
Sales	20,000	60,000	60,000	1,40,000
Less: Variable Cost	6,000	12,000	36,000	54,000
Contribution	14,000	48,000	24,000	86,000

$$\text{Company's P/V Ratio} = C/S \times 100 = \frac{86,000}{1,40,000} \times 100 = 61.43\%$$

$$\text{Company's BEP Ratio} = \frac{FC}{P/V \text{ ratio}} \times 100 = \frac{26,500}{61.43\%} \times 100 = ₹ 43,139$$

Case II (Product A 5,000, Product B 15,000 and Product C 10,000 units)

	A	B	C	Total
Sales	10,000	90,000	40,000	1,40,000
Less: Variable Cost	3,000	18,000	24,000	45,000
Contribution	7,000	72,000	16,000	95,000

$$\text{Company's P/V Ratio} = C/S \times 100 = \frac{95,000}{1,40,000} \times 100 = 67.86\%$$

$$\text{Company's BEP Ratio} = \frac{FC}{P/V \text{ ratio}} = \frac{26,500}{67.86\%} = ₹ 39,050$$

Illustration 9: The following is the data of M Ltd. relating to two types of machines:

Particulars	Existing Machines ₹	New Machines ₹
Output per annum (units)	2000	4000
Capital Cost	25,000	1,00,000
Marginal Cost	15	13
Selling Price	30	30
Fixed Expenses per annum	12,000	32,000
Life	10 years	10 years

The existing machines has completed five years of services and the present resale value is ₹ 10,000. Advice, on the basis of 'annual' comparative data analysis taking into account all aspects and assuming

15% p.a. as the rate of interest, whether the company should go for the new machine or not and also highlight subjective/qualitative factors for consideration of the management in regard thereto.

[M.Com. Modified]

Solution:

Statement of Profitability

Particulars	Existing Machine 2000 units ₹	New Machines 4000 units ₹
Sales		
Marginal Cost p.a.	30,000	52,000
Fixed Expenses p.a.	12,000	32,000
Interest on Additional Capital Required for New Machinery (1,00,000 – 10,000) 15%		13,500
Depreciation	2,500	10,000
Loss on Sale of old Machine over Ten Years (2,500/10)		250
Total Cost	44,500	1,07,750
Total Sales	60,000	1,20,000
Profit per annum	15,500	12,250
CPU	22.25	26.94
Profit per unit	7.75	3.06

Comments:

- (i) The above analysis shows that it will be better to continue with existing machine than replacing it by a new one.
- (ii) Qualitative features:
 - (a) New machine may be of better quality and the output may be doubled to 4,000 and there are chances to increase in the profit if we can raise the selling price of the product.
 - (b) Also there is a possibility of larger market share and hence we can capture the market as the output is doubled.

If we look at short-term point of view, we should go with the existing machine but if we look from long-term perspective, it is advisable to go for the new machine.

(Statement Showing Profits)

Illustration 10: Company makes and sells three products normally X, Y and Z. The unit cost and selling prices are as given below:

Particulars	X (₹)	Y (₹)	Z (₹)
Direct Material	30.00	60.00	80.00
Direct Labour	40.00	40.00	100.00
Variable Overheads	30.00	150.00	70.00
Selling Price	180.00	250.00	480.00

The fixed costs are ₹ 2,70,000

In the month of March and April, number of units sold were as under:

Month	x units	y units	z units
March	1,000	1,000	1,000
April	2,000	1,300	500

You are required to prepare the statement showing the sales and profits for the month of March and April and explain why the profits have fallen down in the month of April in spite of increased sales.

[T.Y. BAF Modified]

Solution:

Statement for Sale and Profit for March

Units Sold	X 1,000 (₹)	Y 1,000 (₹)	Z 1,000 (₹)	Total (₹)
Sales	1,80,000	2,50,000	4,80,000	9,10,000
Less: Direct Material	30,000	60,000	80,000	1,70,000
Less: Direct Labour	40,000	40,000	1,00,000	1,80,000
Less: Variable Overheads	30,000	1,50,000	70,000	2,50,000
Contribution	80,000	Nil	2,30,000	3,10,000
Less: Fixed Cost				2,70,000
Profit				40,000

Units Sold	X 2,000 (₹)	Y 1300 (₹)	Z 500 (₹)	Total (₹)
Sales	3,60,000	3,25,000	2,40,000	9,25,000
Less: Direct Material	60,000	78,000	40,000	1,78,000
Less: Direct Labour	80,000	52,000	50,000	1,82,000
Less: Variable Overheads	60,000	1,95,000	35,000	2,90,000
Contribution	1,60,000	Nil	1,15,000	2,75,000
Less: Fixed Cost				2,70,000
Profit				5,000

Conclusion: The profits have decreased from ₹ 40,000 in March to ₹ 5,000 in April. The contribution is highest for Product Z (i.e. ₹ 230 p.u.). However, in April month sales of Product Z have decreased by 50% and therefore, the profits have also decreased. The contribution in ₹ 80 p.u. for Product X and ₹ Nil p.u. for Product Y.

Illustration 11: A manufacturer of packing cases makes three main types of — Deluxe, Luxury and Economy, overheads are incurred on the basis of labour hours. Wages are paid at ₹ 1.00 per hour. Estimates for the cases show the following:

Particulars	Deluxe (₹)	Luxury (₹)	Economy (₹)
Materials	10	8	3
Wages	6	3	2
Overheads	12	6	4
	28	17	9

Net Profit/ Loss	(2)	3	3
Average Selling Price	26	20	12
Average Sales (Units)	10,000	20,000	5,000

The manufacturer felt that he would be well advised to discontinue producing the deluxe and economy cases even though it would mean that some of production facilities would remain unused. He cannot increase the sales of luxury cases. It has been ascertained that 60% of the overheads is fixed. You are required to advise the manufacturer.

[M.Com. Modified]

Solution:

Statement of Cost and Contribution of Various Products

Particulars	Deluxe (₹)	Luxury (₹)	Economy (₹)
Material	10	8	3
Wages	6	3	2
Variable Overheads 40%	4.8	2.4	1.6
Total Variable Cost	20.8	13.4	6.6
Selling Price	26	20	12
Contribution	5.2	6.6	5.4
Less: Fixed Cost (60%)	7.2	3.6	2.4
Net Profit/Loss	(2)	3	3
P/V Ratio = $C \times 100/SP$	$5.2 \times 100/26 = 20\%$	$6.6 \times 100/20 = 33\%$	$5.4 \times 100/12 = 45\%$

Conclusion: The above statement clearly explains that product Deluxe is incurring loss and also its P/V ratio is less as compared to other two products. Hence, it is recommended that the manufacturer should discontinue the product 'Deluxe' and increase the production of products 'Economy' and by somehow to also increase production of 'Luxury' possible.

Illustration 12: X Ltd. manufactured and sold 14,000 units in the first year and 18,000 units in the second year respectively. The selling price per unit was ₹ 100 in both the years. In the first year, it suffered a loss of ₹ 20,000 and in the second year earned a profit of ₹ 20,000/-. Variable cost is 90% of sales.

Calculate the following:

- The amount of fixed cost.
- The BEP in units and in sales value.
- Profit when 26,000 units are sold.
- The number of units to be sold to earn post-tax profit of ₹ 30,000. Tax rate is 40%.

X Ltd. estimates that its sale will be ₹ Nil in the next year. The competitors has made an offer that it would buy the products of X Ltd. At present, selling price less 10% with a condition that X Ltd. should purchase competitor's product equal to double of the units purchased by the competitors from X Ltd. The competitor's product selling price is ₹ 90 and fetches contribution ₹ 25 per unit. If the competitor's offer is purchased, calculate:

- (a) BEP in units purchased and sold by X Ltd.
 (b) Number of units to be purchased and sold to earn profit of ₹ 40,000.

[CA & CWA Modified]

Solution:

$$\begin{aligned}
 \text{Contribution per unit} &= \text{Change in Profit/Change in Sales (Quantity)} \\
 &= -20,000 - 20,000/14,000 - 18,000 \\
 &= -40,000/-4,000 \\
 &= ₹ 10/- \text{ unit}
 \end{aligned}$$

(a) Ascertainment of Fixed Cost

Particulars	1st Year	2nd Year
Sales	14,00,000	18,00,000
Less: Variable Cost (90%)	12,60,000	16,20,000
Contribution	1,40,000	1,80,000
Less: Fixed Cost	1,60,000	1,60,000
Profit (Loss)	20,000	20,000

(b) Break-even Point

$$\begin{aligned}
 \text{P/V Ratio} &= \text{Contribution/Sales} * 100 \\
 &= 10/100 * 100 \\
 &= 10\%
 \end{aligned}$$

- (i) BEP units = FC/Contribution per unit
 = 1,60,000/10
 = 16,000 units
- (ii) BEP Sales value = FC/P/V Ratio
 = 1,60,000/10%
 = ₹ 16,00,000

(c) Profit when 26,000 units are sold

$$\begin{aligned}
 \text{Margin of Safety} &= \text{Actual Sales} - \text{Break-even Sales} \\
 &= 26,000 - 16,000 \\
 &= 10,000
 \end{aligned}$$

$$\begin{aligned}
 \text{Profit} &= \text{MOS} * \text{Contribution per unit} \\
 &= 10,000 * 10 \\
 &= ₹ 1,00,000
 \end{aligned}$$

(d) No. of units to be sold to earn post-tax profit of ₹ 30,000

Tax rate is 40%

$$\begin{aligned}
 \text{Pre-tax profit} &= 30,000/(100 - 40)\% \\
 &= ₹ 50,000
 \end{aligned}$$

$$\begin{aligned}
 \text{Contribution required to earn pre-tax profit of ₹ 50,000} \\
 &= \text{Fixed Cost} + \text{Profit Required} \\
 &= 1,60,000 + 50,000
 \end{aligned}$$

$$= 2,10,000 \text{ units}$$

Hence, Number of units to be sold to earn post-tax profit of ₹ 30,000

$$= 2,10,000/\text{Contribution per unit}$$

$$= 2,10,000/10$$

$$= 21,000 \text{ units}$$

Received selling price as per competitor's offer

$$\text{Present Selling price} = 100 - 10$$

$$= ₹ 90$$

Revised (S - V)

$$\text{Contribution} = 90 - 90 = \text{Nil}$$

Contribution on sale of competitor's product = ₹ 25

Let X be the number of units sold by X to competitors

Number of competitor's units to be purchased would be 2x

Whereas fixed cost is ₹ 1,60,000

$$25*2x = 1,60,000$$

$$50x = 1,60,000$$

$$X = 3,200 \text{ units}$$

- (a) X Ltd. should purchase 6400 (double the units purchased by competitor's) and sell 3200 units for BEP

Contribution ₹

$$3,200*0 = \text{Nil}$$

$$\text{Contribution} = 6,400*25 = 1,60,000$$

$$\text{Total Contribution} = 1,60,000$$

- (b) Number of units to be purchased and sold to earn a profit of ₹ 40,000

$$\text{Desired Contribution} = \text{FC} + \text{Required Profit}$$

$$= 1,60,000 + 40,000 = ₹ 2,00,000$$

$$25*2x = 2,00,000$$

$$50x = 2,00,000$$

$$X = 4,000 \text{ units}$$

X Ltd. should purchase 8000 units from the competitors and sell 4000 units for earning a profit of ₹ 40,000.

[Make or Buy Decision]

Illustration 13: ABC Ltd. manufactures staplers. All parts of the staplers are manufactured by the company except its metal base plate which is bought from Metal Kings & Co. at a price of ₹ 300 per thousand plates. All sales are in units and these are expected to remain at the same level. Metal Kings & Co. have informed that they would be increasing the price of the plates to ₹ 400 per thousand plates. ABC Ltd. has also now received an offer for use of the unutilised plant space and capacity and is thinking to use the same for manufacture of as an alternative to buying from Metal Kings & Co. ABC Ltd. has also now received an offer use of same unutilised plant space at an annual rent of ₹ 5,000. The cost department of ABC Ltd. has the following relevant data for self-manufacture of the 1,00,000 plates:

Particulars	₹
Raw Materials	8,500
Direct Labour	8,000
Variable Overheads	10,500
General (Fixed) Overheads	14,000

You are required to advise ABC Ltd. giving detailed working and reasoning as to whether it should buy the plates or manufacture them.

[CMA Modified]

Solution:

Statement Showing the cost of Making/Buying and Consequential Effects on Cost 1,00,000 Units

Particulars	Annual Cost		Cost Increase or (Saving)
	Make Plates	Buy Plates	If Plates are Produced
Raw Materials	8,500	–	8,500
Direct Labour	8,000	–	8,000
Variable Overheads	10,500	–	10,500
Fixed Overheads	14,000	14,000	–
Purchase Plates	–	40,000	(–) 40,000
Rent Receivable (Opportunity Cost)	–	(–) 5,000	5,000
	41,000	49,000	(–) 8,000

Cost will reduce by ₹ 8,000 or profit will increase by ₹ 8,000 if the company makes the plates. (General overhead is irrelevant and it has no effect on the decision).

Illustration 14: Shantibai Sweet Softness has introduced a new product ‘Suyash’ consisting of square sweet bars which are wrapped in aluminium foil and packed in attractive cartoons containing 50 bars, which is considered as sales unit. Revenue statements for the last two quarters which are assumed to be representative of the efficiency expected in the next few quarters, reflect the following position assuming no closing stocks at each quarter end:

Particulars	First Quarter (₹)	Second Quarter (₹)
Sales:		
50,000 Cartoons @ ₹ 24	12,00,000	–
70,000 Cartoons @ ₹ 24	–	16,80,000
Cost of Goods Sold	7,00,000	8,80,000
Gross Margin	5,00,000	8,00,000
Selling and Administration Costs	6,50,000	6,90,000
Net Profit (Loss) before Taxes	(1,50,000)	1,10,000
Tax (Negative)	(60,000)	44,000
Net Profit (Loss)	(90,000)	66,000

The firm’s overall marginal and average income tax rate is 40% which has been used to estimate the tax liability arising from sweet operations:

Required:

1. The break-even point in terms of quarterly cartoon sales for the sweet (Suyash) both quantity and valuewise.
2. With quarterly cartoon, quantity sales and total revenue are required in each quarter to earn an after-tax return of 20% p.a. on an investment of ₹30 lakhs in this product line.
3. It is estimated that sales quantity will increase by 20% over the second quarter sales if the selling price is reduced by ₹ 1.50 per cartoon and ₹ 1,50,000 advertising incurred. Should the plan be implemented?

[CA & CS Modified]

Solution:

1. Break-even Point (Quantity and Value)

Calculation of Variable and Fixed Costs:

$$(a) \text{ Variable Cost of Goods Sold} = \frac{\text{Change in Cost}}{\text{Change in Output}} = \frac{\text{₹ } 1,80,000}{20,000} = \text{₹ } 9 \text{ per cartoon}$$

- (b) Fixed Cost of Goods Sold

$$\text{Total Cost} = \text{Fixed Cost} - \text{Variable Cost}$$

$$7,00,000 = \text{Fixed Cost} + (50,000 \times 9)$$

$$\text{Fixed Cost of Goods Sold} = \text{₹ } 2,50,000$$

- (c) Variable Selling and Administration Cost = $\frac{\text{Change in Cost}}{\text{Change in Output}} = \frac{40,000}{20,000} = \text{₹ } 2 \text{ per cartoon}$

- (d) Fixed Cost of Selling and Administration Cost

$$\text{Total Cost} = \text{Fixed Cost} + \text{Variable Cost}$$

$$6,50,000 = \text{Fixed Cost} + (50,000 \times 2)$$

$$\text{Fixed Cost of Selling and Administration Cost} = \text{₹ } 5,50,000$$

$$\text{Total Variable Cost} = 9 + 2 = \text{₹ } 11 \text{ per Cartoon}$$

$$\text{Total Fixed Cost} = 2,50,000 + 5,50,000 = \text{₹ } 8,00,000 \text{ per Quarter}$$

$$\text{BEP (Quantity)} = \frac{\text{Fixed Cost per Quarter}}{\text{Contribution per Quarter}} = \frac{8,00,000}{(24 - 11)} = \frac{8,00,000}{13} = 61,539 \text{ cartoons}$$

$$\text{P/V Ratio} = \frac{\text{Contribution}}{\text{Sales}} \times 100 = \frac{13}{24} \times 100 = 54.166\%$$

$$\text{BEP (Value)} = \frac{\text{Fixed Cost per Quarter}}{\text{P/V Ratio}} = \frac{8,00,000}{54.1666\%} = \text{₹ } 14,76,923$$

2. Annual after Tax Return = $30,00,000 \times 20/100 = \text{₹ } 6,00,000$

$$\text{Quarterly after Tax Return} = 6,00,000 \times 1/4 = \text{₹ } 1,50,000$$

$$\text{Profit} = \text{Contribution} - \text{Fixed Cost}$$

$$1,50,000 = (\text{Sales} \times \text{PV Ratio}) - 8,00,000$$

$$\therefore \text{Sales} = \frac{9,50,000}{54.1666\%} = \text{₹ } 17,53,846$$

$$\therefore \text{Sales (quantity)} = \frac{17,53,846}{24} = 73,077 \text{ cartoons}$$

3. Contribution in Second Quarter = 13 – 1.50 = 11.50 per cartoon
 Revised Fixed Cost = 8,00,000 + 1,50,000 = ₹ 9,50,000 per Quarter
 The Sales Quantity = 70,000 – 20% Increase = 84,000 cartoons
 Profit before Taxes = Contribution – Fixed Cost
 = (84,000 × 11.50) – 9,50,000
 = 9,66,000 – 9,50,000 = ₹ 16,000

The profit before tax is decreasing from ₹ 1,10,000 to ₹ 16,000 and hence the plan should not be implemented.

(Dropping of a Product)

Illustration 15: A manufacturing company makes two products – Luxury and Deluxe. The results for 2019 were as under.

Particulars	Luxury (₹)	Deluxe (₹)
Sales	2,00,000	1,60,000
Variable cost	1,20,000	1,32,000
Fixed Cost	40,000	32,000
Profit/Loss	40,000	(-) 4,000

The managing director has suggested that Deluxe should be dropped as it is making loss. It is estimated that ₹ 8,000 will be saved in fixed overheads as his suggestion is implemented. Should Deluxe be dropped, if:

1. His decision has no effect on sales of Luxury;
2. By using the vacant factory space, sales of Luxury could be increased by ₹ 1,00,000, the extra production would lead to increase in the total fixed cost to ₹ 76,000.

[M.Phil Modified]

Solution:

Particulars	Luxury ₹	Deluxe ₹
Sales	2,00,000	1,60,000
Less: Variable Cost	1,20,000	1,32,000
Contribution	80,000	28,000
Less: Fixed Cost	40,000	32,000
Net Profit/Loss	40,000	(-) 4,000
P/V Ratio = C × 100/SP	= 80,000 × 100/2,00,000 = 40%	= 28,000 × 100/1,60,000 = 17.50%

Advice: Since the P/v ratio of 'Deluxe' is less, it should be dropped and increase the production of Luxury.

Revived P/V Ratio:

Particulars	Luxury (₹)
Sales	3,00,000
Less: Variable Cost	1,20,000
Contribution	1,80,000
Less: Fixed Cost	76,000
Net Profit	1,04,000

$$P/V \text{ Ratio} = 1,80,000 \times 100/3,00,000 = 60\%$$

Since the P/V ratio of Luxury is more in both cases, it would be preferable to increase production of Luxury as the contribution is more.

(Acceptance or Rejection of Special Export Order)

Illustration 16: Silver Line Ltd. market two brands (A and B) of same product line. Relevant figures about its operations during the year 2019 were.

Particulars	A	B
Units Sold	80,000	60,000
Selling Price per unit (₹)	170	120
Materials Cost per unit (₹)	50	40
Direct Labour per unit (₹)	30	20
Production overhead (50% Fixed)	40	40

Marketing manager proposes two alternatives plans for the year 2020.

- Increase product A market by 40% (no growth for product B).
- Increase product B market by 100% (no growth for product A).

Company can manage either of the plans without any increase in the current level of fixed expenses. Further, selling and distribution expenses are 5% of sales realisation.

You are required to present the detailed calculations of costs and revenues of the alternate plans and advise the management – which one to accept?

[CS & CMA Modified]

Solution:**Calculation of Costs and Revenues of the Alternate Plans**

Product	A Per Unit	B Per Unit	CPU
A. Selling Price	170	120	
B. Variable Cost:			
Material	50	40	
Labour	30	20	
Variable Overheads	20	20	
Selling & Distribution Overheads	8.50	6	

Total VC	108.50	86	
C. Contribution (A – B)	61.50	34	
Units Sold	80,000	60,000	
Total Contribution	49,20,000	20,40,000	69,60,000
Less: Fixed Cost (20 * 80,000) + (20 * 60,000)			28,00,000
Profit			41,60,000

Plan A: Increase Product A market by 40%

Particulars	A	B	Total (₹)
Units	80,000 + 40% = 1,12,000	60,000	
Contribution per unit	61.50	34	
Total Contribution	68,88,000	20,40,000	89,28,000
Less: Fixed Cost			28,00,000
Profit			61,28,000

Plan B: Increase Product B market by 100%

Particulars	A	B	Total (₹)
Units	80,000	60,000 + 100% = 1,20,000	
Contribution p.u.	61.50	34	
Total Contribution	49,20,000	40,80,000	90,00,000
Less: Fixed Cost			28,00,000
Profit			62,00,000

Conclusion: Proposal B should be accepted, i.e., increase the Product B by 100%. It increase the profit to ₹ 62,00,000 as compared to the existing profit which is ₹ 41,60,000.

Illustration 17: The Jaya Snow Company manufactures and sells direct to consumers 5000 jars of snow per month at ₹ 25 per jar. The company's normal production capacity is 10000 jars per month. An analysis of cost for 5000 jars is given below:

Particulars	₹
Direct Material	20,000
Direct Labour	49,500
Power	2,800
Other Expenses	8,600
Cost of Jars	12,000
Fixed Expenses	1,59,100
	2,52,000

The company has received an offer for the export under a differential brand name of 60,000 jars of snow at 5,000 jars per month at ₹ 15 a year. Write a short report on the advisability or otherwise of accepting the offer.

[CA & CS Modified]

Solution:**Marginal Contribution Analysis of the Present and Proposed Position**

Particulars	Per Unit	Present Position Capacity 50%	Proposed Offer Capacity 50%	Total Capacity 100%
Sales (Units)		5,000	5,000	10,000
	₹	₹	₹	₹ (@ ₹ 15 per jar)
Sales (Value)	25	1,25,000	75,000	2,00,000
Less: Direct Materials	4	20,000	20,000	
Direct Labour	9.9	49,500	49,500	
Power	0.56	2,800	2,800	
Other Expenses	1.72	8,600	8,600	
Cost of Sales	2.4	12,000	12,000	
Variable Cost	18.58	92,900	92,900	1,85,800
Marginal Contribution	6.42	32,100	(-)17,900	14,200
Fixed Cost				1,59,100
Loss				1,44,900

The proposed offer at lower price will decrease the contribution to the extent of ₹ 17,900. The proposal should not be accepted since there is decrease in the total contribution. The following further points should be kept in view:

- (i) The extent of additional export costs to be incurred.
- (ii) Consideration of opportunity cost whether the additional capacity could be utilised for production of other more profitable products
- (iii) Whether there is any risk of dumping, i.e., re-export by the foreign customer so that the company will be faced with competition with itself.
- (iv) Long-term effect of the reduced export price on the home market.

Illustration 18: A manufacturer has planned his level of operation at 50% of his plant capacity of 30,000 units. His expenses are estimated as follows, if 50% of the plant capacity is utilised:

- (i) Direct Materials ₹ 8,280/-
- (ii) Direct Wages ₹ 11,160/-
- (iii) Variable and other manufacturing expenses ₹ 3,960/-
- (iv) Total Fixed Expenses irrespective of capacity utilisation ₹ 6,000/-

The expected selling price in the domestic market is ₹ 2/- per unit. Recently, the manufacturer has received a trade enquiry from an Overseas Organisation interested in purchasing 6000 units at a price of ₹ 1.45 per unit.

As a professional Management Accountant, what would be your suggestions regarding acceptance or rejection of the order?

[M.Com. & M.Phil Modified]

Solution:**Marginal Contribution Analysis Showing Present and Proposed Position**

Particulars	Per Unit ₹	Present Position 50%	Proposed Offer 20%	Total 70%
			15,000 Units	6,000 @1.45
Sales	2.000	30,000	8,700	38,700
<i>Less: Variable Cost:</i>				
Direct Material	0.552	8,280	3,312	11,592
Direct Labour	0.774	11,160	4,464	15,624
Variable & Other Manufacturing Overhead	0.264	3,960	1,584	5,544
Total Variable Cost	1.560	23,400	9,360	32,760
Contribution (S – V)	0.440	6,600	(660)	5,940
<i>Less: Fixed Cost</i>		6,000	—	(6,000)
Profit		600	(660)	(60)

The proposed offer at lower price, i.e., at ₹ 1.45 is lower than the Marginal Cost which comes out to be ₹ 1.56 per unit. If the proposal is accepted, there will be loss of ₹ 0.11 (1.56 – 1.45) per unit. Hence, the total contribution lost on 6000 units would be ₹ 660. Therefore, the proposal should not be accepted. The following factors should be kept in mind:

- (i) Additional export costs to be incurred.
- (ii) Opportunity cost.
- (iii) Risk of dumping, i.e., re-export by the foreign customer so that the company will be faced with competition with itself.
- (iv) Effect of the reduced export price on the home market.

Illustration 19: The cost sheet of product as follows:

Particulars	Per unit (₹)
Direct Materials	10.00
Direct Wages	05.00
Factory Overheads:	
Fixed	01.00
Variable	02.00
Administrative Expenses	1.5
Selling and Distribution Expenses:	
Fixed	00.50
Variable	01.00
Cost of Sales	21.00

The selling price per unit is ₹ 25.00. The above cost information is for an output of 50,000 units whereas the capacity of firm is 60,000 units. A foreign customer is desirous of buying 10,000 units at a price of ₹ 19.00 per unit. The extra cost of exporting the product is ₹ 0.50 per unit. You are required to advise the manufacturer whether the order should be accepted.

[M.Com. Modified]

Solution

Evaluation of Export Offer

Particulars	50,000 Units		60,000 Units	
	Amount ₹	Per Unit ₹	Amount ₹	Per Unit ₹
Sales (50,000 * 25)	12,50,000	.	12,50,000	
(10,000 * 19)	–		1,90,000	
Total Sales (A)	12,50,000	25	14,40,000	24
Variable Costs:				
Direct Materials	5,00,000	10	6,00,000	10
Direct Wages	2,50,000	5	3,00,000	5
Cost of Export	–	–	5000	0.50
Factory Overhead	1,00,000	2	1,20,000	2
Selling and Distribution	50,000	1	60,000	1
Total Variable Cost (B)	9,00,000	18	10,85,000	18.08
Contribution (C) = (A) – (B)	3,50,000	7	3,55,000	5.92
Fixed Assets:				
Factory Overhead	50,000	1	50,000	0.83
Administration Overhead	75,000	1.5	75,000	1.25
Selling and Distribution	25,000	0.5	25,000	0.42
Total Fixed Costs (D)	1,50,000	3	1,50,000	2.5
Profit = (C) – (D)	2,00,000	4	2,05,000	3.42

Conclusion: If the foreign order is accepted, profits of the manufacturer increases from ₹ 2,00,000 to ₹ 2,05,000 Profits increases by ₹ 5,000 and therefore, foreign order should be accepted by the manufacturer.

Illustration 20: A firm already in production gives to you its following detail:

Annual Capacity (Units)	Unit Cost ₹	Unit Price ₹
6,000	80	100
7,000	75	97
8,000	74	95
9,000	72	
10,000	71	

The firm is operating at 8,000 units capacity at present and cannot exceed, in any case, totally 15,000 units capacity level by any means. Under the circumstances, the firm receives two alternative additional order, only one of which it can accept:

- For 2,000 units from an export market at a price of ₹ 70 per unit.
- For 7,000 units from another export market at a price of ₹ 75 per unit and it is given that the firm has to increase its establishment for going from 10,000 units to 15,000 units which would result into additional fixed cost of ₹ 30,000 per annum in addition to the per unit cost of ₹ 71 at 10,000 units level which would remain the same even subsequently, i.e., at the level of 15,000 units.

Advise the firm as to whether any of the alternative additional export orders should be accepted or not, and if yes, which one?

[M.Com. & T.Y.BAF Modified]

Solution:

Operating at 8,000 units

Units	Cost	Sales revenue	Additional profit
(a) 2000	1,18,000	1,40,000	22,000 (₹11/unit)
	(7,10,000 – 5,92,000)	(2,000 * 70)	(70 – 59) * 2,000
8,000	5,92,000	7,60,000	1,68,000
10,000	7,10,000	9,00,000	1,90,000
		[7,60,000 + (2,000 * 70)]	
(b) Additional 7,000	5,03,000	5,25,000	
	[10,65,000 – 5,92,000 + 30,000 (FC)]	(7,000 × 75)	22,000
	10,95,000	12,85,000	19,000
(c) Total 15,000	10,65,000 + 30,000	[7,60,000 + 7,000 × 71]	

Additional Profit is ₹ 22,000

Advice: Any of the above two alternative export orders may be accepted, as both are equally profitable. However, (a) is more advisable in case of double as to stability of demand as fixed cost do not rise.

Conclusion: In both the cases, additional profit will be ₹ 1,90,000. Hence, any of the export order may be accepted.

However, 'a' is preferable as additional fixed cost is to incurred the case of 'b'.

Illustration 21: M/s Alok Industries has given the following details. Find the most profitability product mix and prepare a statement of the product mix.

Particulars	Product X	Product Y	Product Z
Units budgeted to be produced and sold	1,800	3,000	1,200
Selling price per unit (₹)	60	55	50
Requirements per unit:			
Direct materials	5 kg	3 kg	4 kg

Direct labour	4 hrs.	3 hrs	2 hrs
Variable overheads	₹ 7	₹ 13	₹ 8
Fixed overheads	₹ 10	₹ 10	₹ 10
Cost of direct material per kg	₹ 4	₹ 4	₹ 4
Direct labour hour rate	₹ 2	₹ 2	₹ 2
Maximum possible units of sales	4,000	5,000	1,500

All the above products are produced from the same direct materials using the same type of machines and labour. Direct labour, which is the key factor, is limited to 18,600 hours.

[CA Modified]

Solution:

M/s Alok Industries
Calculation of Contribution per Direct Labour Hours and Ranking

Particulars	Products		
	X	Y	Z
A. Selling Price per (₹)	60	55	50
Less: Variable Cost per unit (₹):			
Direct Materials	20	12	16
Direct Labour	8	6	4
Variable Overheads	7	13	8
B. Total Variable Cost per unit (₹)	35	31	28
Contribution (A – B) (₹)	25	24	22
Direct Labour Hours per unit	4	3	2
Contribution per Hour (C/DLH)	6.25	8	11
Ranking	III	II	I

Statement of Profitability

Particulars	Products			Total
	X	Y	Z	
Units Produced and Sold	150	5,000	1,500	–
Contribution per unit (₹)	25	24	22	–
Total Contribution	3,750	1,20,000	33,000	1,56,750
Less: Fixed Overheads @ ₹ 10 for Budgeted Units	18,000	30,000	12,000	(60,000)
				96,750

Working Note:

Profit

Allocation of Direct Labour Hours for Most Profitable Product Mix	
Total Direct Labour Hours Available	18,600
Less: Utilised for 1,500 Units of Product Z (1,500*2)	3,000
Balance hrs available	15,600
Less: Utilised for 5,000 units of Product Y (5,000*3)	15,000
Balance Utilised for 150 units of Product X (150 × 4)	600

Illustration 22: (Limiting Factor): Vishaka Ltd. produces three products furnishes you the following data for 2018-19

Particulars	Product		
	Delux	Super Delux	Premium
Selling Price Per Unit	200	150	100
Profit Volume Rate in %	10	30	40
Maximum Sales Potential	80,000	50,000	20,000
Raw Material as Percentage of Variable Cost in %	50	50	50

The fixed expenses are estimated at ₹ 27,20,000. The company uses a single raw material in all the three products.

Raw material is in short supply and the company has a quota for the supply of raw materials of the value ₹ 72,00,000 for the year for the manufacture of its product to meet its sales demand.

You are required to

- Set a sales mix which will give a maximum overall profit keeping in view the availability of raw materials in value.
- With the sale mix calculated above, compute the profit

Solution:

Product	Selling Price Per Unit	P/V Ratio	Variable Cost as % of Selling Price	Variable Cost Per Unit	Material Content @ 50% of variable cost	Contribution Per Unit (SP Less VC)	Contribution Based on Key Factor (Raw Material)	Rank
Delux	200	10%	90%	180	90	20	22.222	III
Super Delux	150	30%	70%	105	52.5	45	85.714	II
Premium	100	40%	60%	60	30	40	133.333	I

$$\text{Contribution Based on Key Factor} = \frac{\text{Contribution Per Unit}}{\text{Material Content @ 50\% of Variable Cost}} \times 100$$

		₹
Total Material Available		72,00,000
Utilised for Product Premium	20,000 Unit × 30	6,00,000
Balance		66,00,000
Utilised for Product Super Delux	50,000 × 52.5	26,25,000
Balance Available		39,75,000
Product Delux	44,166 × 90	39,75,000

After producing Premium and Super Delux the balance material available can be utilised for product Delux.

Computation of maximum profit

Product	Units	Contribution per unit	Total Contribution
Delux	44,166	20	8,83,320
Super Delux	50,000	45	22,50,000
Premium	20,000	40	8,00,000
Contribution			39,33,320
Fixed Cost			27,20,000
Profit			12,13,320

Illustration 23: (Profitable Product): Ajanta company earned profit of ₹ 20,00,000 after meeting cost of 28,00,000 selling price per unit is 100 and variable cost is ₹ 40 per unit

The sales manager has suggested three different alternatives as under:

Alternative	Reduce Present Selling Price Per Unit By	Increase sale Quantity Present Level by
P	5%	10%
Q	7%	20%
R	10%	25%

Prepare working of profitability under each alternative and recommend the most profitable alternative.

$$\begin{aligned}
 \text{Present Sales in Units} &= \frac{20,00,000 + 28,00,000}{100 - 40} \\
 &= \frac{48,00,000}{60} \\
 &= 80,000 \text{ Units}
 \end{aligned}$$

Particulars	Alternative P	Alternative Q	Alternative R
Sales in Units	88,000	96,000	1,00,000
Selling Price Per Unit	95	93	90
Variable Cost	40	40	40
Revised Contribution	55	53	50
Total Contribution	48,40,000	50,88,000	50,00,000
Less: Fixed Cost	28,00,000	28,00,000	28,00,000
Profit	20,40,000	22,88,000	22,00,000

Alternative Q is the most profitable.

Exercise

1. A company manufactures and sells two products and presents the following cost structure and selling:

Particulars	Product M	Product N
Direct Materials Per Unit	₹ 25	₹ 30
Direct Labour Hour Per Unit	10 hours	12 hours
Direct Labour Hour Rate	₹ 2 per hour	₹ 2 per hour
Variable Factory Overhead	100 of Direct Labour	100 of Direct Labour
Selling Price Per Unit	₹ 75	₹ 90

Fixed Cost ₹ 10,000.

The marketing manager has suggested the following sales options:

Option	Unit of M	Unit of N
I	800	600
II	1,600	-
III	-	1,300
IV	1,100	500

Prepare marginal cost statement of two products. Evaluate sales options and suggest best profitable sales mix. [M.Com Modified]

Ans. IV

2. Financial Accountant of PSC Ltd. has presented the following product for Performance Report for the year ended March, 2010:

Particulars	₹
Sales @ ₹ 10 per unit	10,00,000
Total Variable Cost	7,00,000
Fixed Cost	2,00,000
Profit	1,00,000

The Marketing Manager of the company has come up with a proposal that if the selling price of the product is reduced by 100% the quantity sold will go up by 25%. On the other hand, the Costing Department is of the opinion that as most of the competitors have higher prices, the selling price should be increased by 10%. The Marketing Manager has apprehension that if the selling price is increased by 10%, the quantity sold will fall by 20%. You are invited by the company to analyse the situation and advise the company to take a decision with reasons:

- The Selling Price should be increased or
- The Selling Price should be reduced or
- The Selling Price should be left unchanged.

[CS Modified]

Ans.: ₹ 1,20,000, ₹ 50,000, ₹ 1,00,000

3. The following relevant data of a firm is given:

Particulars	Activity Levels (Tonnes)			
	50,000 tonnes	60,000 tonnes	70,000 tonnes	80,000 tonnes
Variable cost (₹ in thousands)	5,000	6,000	7,000	8,000
Semi-variable cost (₹ in thousands)	1,500	1,600	1,650	1,700
Fixed cost (₹ in thousands)	2,500	2,500	3,000	3,000
Total cost (₹ in thousands)	9,000	10,100	11,650	12,700

The fixed costs follow step-graph pattern as is clear from the above and the semi-variable costs change at uniform rate between the above given activity level. Given that the firm operates at 55,000 tonnes level at present,

- (a) Calculate the additional/incremental costs if it manufactures: (a) 10,000 tonnes and (b) 15,000 tonnes.
- (b) Advice whether the firm should accept ‘any one’ of the following additional (special) export market offers and if yes ‘which one’ should it accept:
 - (i) For 10,000 tonnes at a selling price of ₹ 125/- per tonne
 - (ii) For 15,000 tonnes at a selling price of ₹ 150/- per tonne

Ans.: ₹ 1,75,000, ₹ 1,50,000

[CA Modified]

4. Diversity & Co. manufactures five different products Alpha, Beeta, Gama, Theeta and Delta from the same raw material which is in short supply, viz., available only to the extent 5,000 kgs. The following relevant data is available to you:

Particulars	Alpha	Beeta	Gama	Theeta	Delta
Maximum Sales (units)	1,500	2,500	1,600	2,000	2,200
Production per unit	2,000	3,000	1,500	2,000	2,000
Selling Price per unit (₹)	4	3.5	1.5	1	3
Marginal Cost per unit (₹)	3	2	1.25	0.75	2.5
Raw Material (kgs) per unit	2	8	3	5	2

You are required to:

- (a) Determine the most profitable production mix:
- (b) Given the mix derived in (a) above is being produced, determine which of the following two alternative proposals should the enterprise accept in order to increase its profit:
 - (i) Improve quality and sell at the same price to sell an additional quality of 500 units, the quality improvement costs increasing the marginal costs by ₹ 0.15 per unit;
 - (ii) Reduce the selling price by ₹ 0.05 per unit to sell an additional quantity of 400 units.

[CMA Modified]

5. Following data relates to a company which manufactures a single product:

Product Cost:	
Variable	₹ 2/- per unit
Fixed cost	₹ 80,000

Assets:	
Working Capital	₹ 1,00,000/-
Fixed Cost	₹ 2,00,000/-
	₹ 3,00,000/-

The desired rate of return on the capital employed by the company is 30% and the Divisional Manager has fixed the selling price of the product at ₹ 2.50 per unit.

- (i) Calculate the number of the units which the division should produce and sell to achieve the target return.
- (ii) The product is also unable as a raw material in another division of the same enterprise. It is supposed that out of the total units manufactured as per item (i) above 60,000 units be transferred to the other division. The transfer price under discussion. The transfer is insisting that the price be fixed at ₹ 2.30 per unit which is the price which it can be procured from the market. The transferee divisional manager states that if no transfer is made and production is curtailed accordingly, there will be reduction in the working capital, Fixed assets and fixed costs to the extent of ₹ 10,000/- each. You are required to give your comments regarding the proposed transfer price of ₹ 2.30 per unit.
- (iii) Suppose that it is agreed that the transfer to the other division be made at price of ₹ 2.30 per units, at what price should it transfer or sell the remaining units so as to maintain the desired return of 30%? Alternatively, how many more units it should produce assuming that this will not make any change in the fixed cost, the asset cost or the selling price.

[CA Modified]

Ans: (i) 3,40,000, (ii) Yes, (ii) 3,04,000 Units

6. Modern Chair Manufacturing Company received an offer to sell 25000 outdoor patro chairs to Easy Lift Corporation. Modern Chair Manufacturing Company produces 400000 chairs annually by operating at 80% full capacity. Regular selling price for this type of chairs is ₹ 33. The chairs required are similar to those currently being produced by Modern Chairs Manufacturing company. Budgeted annual production costs and other expenses are as follows:

Particulars	Per Unit ₹	Total ₹
Raw Material	4.25	1,70,0000
Direct Labour	5.75	2,30,0000
Variable Factory Overhead	7.75	31,00,000
Fixed Factory Overhead	—	25,00,000
Variable Selling Costs	—	5% of Sales Price
Fixed Selling and Administrative Overhead	—	14,50,000

The company wants to earn a minimum profit of rupee one per chair and no selling expenses will be incurred for special order transaction. Assume that normal operations will not be affected by the special order and that the regular sales volume for the year is 400000 chairs as initially planned you are required to:

- (a) Find out what should be the minimum price to be quoted by Modern Chair Manufacturing Company?

- (b) Prepare an income statement showing the position of the company without special order, for special order and with special order.

[M.Com. Modified]

Ans.: (a) ₹ 81,25,000, (b) ₹ 14,50,000

7. From the following data, which product would you recommend to be manufactured in a factory, time being the key factor?

Per Unit of Product	A (₹)	B (₹)
Direct Material	24	14
Direct Labour (₹ 1 per hr.)	2	13
Variable Overhead (₹ 2 per hr.)	4	6
Selling Price	100	110
Standard Time to Produce	2 hours	3 hours

[M.Com. Modified]

Ans.: Product A

8. Suyush Ltd. is considering launching a new monthly magazine at a selling price of ₹ 10 per copy. Sales of the magazine are expected to be 5,00,000 copies per month but it is possible that the actual sales could differ quite significantly from the estimate.

Two different methods of producing the magazines are being considered and neither would involve any additional capital expenditure. The estimated production cost for each of the two methods of manufacture, together with the additional marketing and distribution costs of selling the new magazine, are given below:

Particulars	Method A	Method B
Variable Costs	₹ 5.50 per Copy	₹ 5.00 per Copy
Specific Fixed Costs	₹ 8,00,000 p.m.	₹ 12,00,000 p.m.
Semi-variable Copies:		
For 3,50,000 Copies	₹ 5,50,000 p.m.	₹ 4,75,000 p.m.
For 4,50,000 Copies	₹ 6,50,000 p.m.	₹ 5,25,000 p.m.

- (i) It may be assumed that the fixed cost element of semi variable cost will remain constant throughout the range of activity shown.
- (ii) The company currently sells a magazine covering related topics to those that will be included in the new publication and consequently it is anticipated that sales of that existing magazine will be adversely affected.
- (iii) It is estimated that for every ten copies sold off the new publication, sale of the existing magazine are as follows:

Sales	2,20,000 Copies p.m.
Selling Price	₹ 8.50 per Copy
Variable Costs	₹ 3.50 per Copy
Specific Fixed Costs	₹ 8,00,000 p.m.

You are required to calculate for each production method:

- (i) The net increase in company profit which will result from the introduction of the new magazine, at each of the following levels of activity
- | | | | |
|----------|----------|----------|------------------|
| 5,00,000 | 4,00,000 | 6,00,000 | copies per month |
|----------|----------|----------|------------------|
- (ii) The amount by which sales volume of the now magazine could decline from the anticipated 5,00,000 copies p.m., before the company makes no additional profit from the introduction of the new publication.

And also briefly identify any conclusion which may be drawn from your calculations.

[CA Modified]

Ans.: If the copies sold (of new magazine) are below 5,00,000 copies then method A is better and if it is above 5,00,000 copies then method B is better

9. A pen manufacturer makes an average profit of ₹ 25,000 per pen on a selling price of ₹ 143 by producing and selling 60,000 pens or 60% of the potential capacity. His cost of sales is:

Direct Materials	₹ 35.00
Direct Wages	₹ 12.50
Works Overheads (50% Fixed)	₹ 62.50
Sales Overheads (25% Variable)	₹ 08.00

During the current year, he intends to produce the same number of pens but anticipates that his fixed charges will go up by 10% while rates of direct labour and direct material will increase by 8% and 6% respectively. But he has no option of increasing the selling price under the situation. He obtain offer for a further 20% of his capacity. What minimum price will you recommend for acceptance to ensure the manufacturer and overall profit of ₹ 16,73,000?

[CA Modified]

Ans.: ₹ 13550

10. Jay-Vijay Company is at present operating at 60% capacity producing at the rate of 10,000 units a months – a single product sells for ₹ 9.00 a unit for the year 2019, the results have been as follows:

Particulars	₹	₹
Sales: 1,20,000 Units at ₹ 9.00 per unit		10,80,000
Cost of Sales:		
Direct Materials	1,80,000	
Direct Labour	3,60,000	
Variable Overheads	90,000	
Fixed Manufacturing Overheads	1,35,000	
		7,65,000
Gross Profit		3,15,000
Selling Expenses:	50,000	
Fixed	36,000	
Variable		

Administrative Expenses:		
Fixed	22,000	
		1,08,000
Profits		2,07,000

Although the company is operating relatively at the high net profit at a plant capacity of 60%, it is a fact that the price per unit could be reduced by 20%, the value of sales would increase to 1,80,000 units per year with an increase in the fixed manufacturing overheads of ₹ 9,000 per year. If sales price could be reduced by 33%, the volume of sales could increase to full capacity (20,00,000) units with increase in expenses at 60% levels as follows:

- (a) Fixed manufacturing overheads – ₹ 11,000
- (b) Fixed selling expenses – ₹ 2000
- (c) Fixed administration expenses – ₹ 6,000

You are required to:

- (i) Prepare a comparative statement showing net income under the three alternative profit volume relationships and
- (ii) Compute the break-even sales point in each.

[CMA modified]

Objective Questions

I. Fill in the Blanks

1. Relevant Costs are costs which would _____ as a result of the decision.
2. _____ are historical cost that cannot be recovered in a given situation.
3. Opportunity costs are _____ for not pursuing the alternative course.
4. _____ is also known as discretionary cost.
5. Budgets are not actual but _____.
6. After setting up objectives in terms of plans, it becomes imperative to organise the factors of production to convert into a _____ and _____.
7. _____ signifies such systematic efforts which help the management to know whether actual performance is in line with predetermined goal, policy and plans.
8. Internal refinement, broad indexation of activities and concentrated details is the essential features in _____.

[Ans.: 1. Change, 2. Sunk cost, 3. Monetary benefits foregone, 4. Avoidable cost, 5. Estimates, 6. Reality and workable preposition, 7. Control 8. Planning.]



STANDARD COSTING AND VARIANCE ANALYSIS

Introduction

You know that management accounting is managing a business through accounting information. In this process, management accounting is facilitating managerial control. It can also be applied to your own daily/monthly expenses, if necessary. These measures should be applied correctly so that performance takes place according to plans. Planning is the first tool for making the control effective. The vital aspect of managerial control is cost control. Hence, it is very important to plan and control costs. Standard costing is a technique which helps you to control costs and business operations. It aims at eliminating wastes and increasing efficiency in performance through setting up standards or formulating cost plans.

Meaning of Standard

When you want to measure something, you must take some parameter or yardstick for measuring. We can call this as standard. What are your daily expenses? An average of ₹50! If you have been spending this much for so many days, then this is your daily standard expense.

The word standard means a benchmark or yardstick. The standard cost is a predetermined cost which determines in advance what each product or service should cost under given circumstances.

In the words of Backer and Jacobsen, “Standard cost is the amount the firm thinks a product or the operation of the process for a period of time should cost, based upon certain assumed conditions of efficiency, economic conditions and other factors.”

Definition

The CIMA, London has defined standard cost as “a predetermined cost which is calculated from management standards of efficient operations and the relevant necessary expenditure.” They are the predetermined costs on technical estimate of material labour and overheads for a selected period of time and for a prescribed set of working conditions. In other words, a standard cost is a planned cost for a unit of product or service rendered.

The technique of using standard costs for the purpose of cost control is known as standard costing. It is a system of cost accounting which is designed to find out how much should be the cost of a product under the existing conditions. The actual cost can be ascertained only when production is undertaken. The predetermined cost is compared to the actual cost and a variance between the two enables the management to take necessary corrective measures.

Advantages

Standard costing is a management control technique for every activity. It is not only useful for cost control purposes but is also helpful in production planning and policy formulation. It allows management by exception. In the light of various objectives of this system, some of the advantages of this tool are given below:

- 1. Efficiency measurement:** The comparison of actual costs with standard costs enables the management to evaluate performance of various cost centres. In the absence of standard costing system, actual costs of different period may be compared to measure efficiency. It is not proper to compare costs of different period because circumstance of both the periods may be different. Still, a decision about base period can be made with which actual performance can be compared.
- 2. Finding of variance:** The performance variances are determined by comparing actual costs with standard costs. Management is able to spot out the place of inefficiencies. It can fix responsibility for deviation in performance. It is possible to take corrective measures at the earliest. A regular check on various expenditures is also ensured by standard cost system.
- 3. Management by exception:** The targets of different individuals are fixed if the performance is according to predetermined standards. In this case, there is nothing to worry. The attention of the management is drawn only when actual performance is less than the budgeted performance. Management by exception means that everybody is given a target to be achieved and management need not supervise each and everything. The responsibilities are fixed and everybody tries to achieve his/her targets.
- 4. Cost control:** Every costing system aims at cost control and cost reduction. The standards are being constantly analysed and an effort is made to improve efficiency. Whenever a variance occurs, the reasons are studied and immediate corrective measures are undertaken. The action taken in spotting weak points enables cost control system.
- 5. Right decisions:** It enables and provides useful information to the management in taking important decisions. For example, the problem created by inflating, rising prices. It can also be used to provide incentive plans for employees, etc.
- 6. Eliminating inefficiencies:** The setting of standards for different elements of cost requires a detailed study of different aspects. The standards are set differently for manufacturing, administrative and selling expenses. Improved methods are used for setting these standards. The determination of manufacturing expenses will require time and motion study for labour and effective material control devices for materials. Similar studies will be needed for finding other expenses. All these studies will make it possible to eliminate inefficiencies at different steps.

Limitations of Standard Costing

1. It cannot be used in those organisations where non-standard products are produced. If the production is undertaken according to the customer specifications, then each job will involve different amount of expenditures.
2. The process of setting standard is a difficult task, as it requires technical skills. The time and motion study is required to be undertaken for this purpose. These studies require a lot of time and money.

3. There are no inset circumstances to be considered for fixing standards. The conditions under which standards are fixed do not remain static. With the change in circumstances, if the standards are not revised the same becomes impracticable.
4. The fixing of responsibility is not an easy task. The variances are to be classified into controllable and uncontrollable variances. Standard costing is applicable only for controllable variances.

For instance, if the industry changed the technology then the system will not be suitable. In that case, we will have to change or revise the standards. A frequent revision of standards will become costly.

Setting Standards

Normally, setting up standards is based on the past experience. The total standard cost includes direct materials, direct labour and overheads. Normally, all these are fixed to some extent. The standards should be set up in a systematic way so that they are used as a tool for cost control.

Various elements which Influence the Setting of Standards

Setting Standards for Direct Materials

There are several basic principles which ought to be appreciated in setting standards for direct materials. Generally, when you want to purchase some material what are the factors you consider. If material is used for a product, it is known as direct material. On the other hand, if the material cost cannot be assigned to the manufacturing of the product, it will be called indirect material. Therefore, it involves two things:

- Quality of material
- Price of the material

When you want to purchase material, the quality and size should be determined. The standard quality to be maintained should be decided. The quantity is determined by the production department. This department makes use of historical records, and an allowance for changing conditions will also be given for setting standards. A number of test runs may be undertaken on different days and under different situations, and an average of these results should be used for setting material quantity standards.

The second step in determining direct material cost will be a decision about the standard price. Material's cost will be decided in consultation with the purchase department. The cost of purchasing and store keeping of materials should also be taken into consideration. The procedure for purchase of materials, minimum and maximum levels for various materials, discount policy and means of transport are the other factors which have bearing on the materials cost price. It includes the following:

- Cost of materials
- Ordering cost
- Carrying cost

The purpose should be to increase efficiency in procuring and storekeeping of materials. The type of standard used – ideal standard or expected standard – also affects the choice of standard price.

Setting Direct Labour Cost

If you want to engage a labour force for manufacturing a product or a service for which you need to pay some amount, this is called wages. If the labour is engaged directly to produce the product, this is known as direct labour. The second largest amount of cost is of labour. The benefit derived from the workers can be assigned to a particular product or a process. If the wages paid to workers cannot be directly assigned to a particular product, these will be known as indirect wages. The time required for producing a product would be ascertained and labour should be properly graded. Different grades of workers will be paid different rates of wages. The times spent by different grades of workers for manufacturing a product should also be studied for deciding upon direct labour cost. The setting of standard for direct labour will be done basically on the following:

- Standard labour time for producing
- Labour rate per hour

Standard labour time indicates the time taken by different categories of labour force which are as under:

- Skilled labour
- Semi-skilled labour
- Unskilled labour

For setting a standard time for labour force, we normally take in to account previous experience, past performance records, test run result, work-study etc. The labour rate standard refers to the expected wage rates to be paid for different categories of workers. Past wage rates and demand and supply principle may not be a safe guide for determining standard labour rates. The anticipation of expected changes in labour rates will be an essential factor. In case there is an agreement with workers for payment of wages in the coming period, these rates should be used. If a premium or bonus scheme is in operation, then anticipated extra payments should also be included. Where a piece rate system is used, standard cost will be fixed per piece. The object of fixed standard labour time and labour rate is to device maximum efficiency in the use of labour.

Setting Standards of Overheads

The next important element comes under overheads. The very purpose of setting standard for overheads is to minimise the total cost. Standard overhead rates are computed by dividing overhead expenses by direct labour hours or units produced. The standard overhead cost is obtained by multiplying standard overhead rate by the labour hours spent or number of units produced. The determination of overhead rate involves three things:

- Determination of overheads
- Determination of labour hours or units manufactured
- Calculating overheads rate by dividing A by B

The overheads are classified into fixed overheads, variable overheads and semi-variable overheads. The fixed overheads remain the same irrespective of level of production, while variable overheads change in the proportion of production. The expenses increase or decrease with the increase or decrease in output. Semi-variable overheads are neither fixed nor variable. These overheads increase with the increase in production but the rate of increase will be less than the rate of increase in production. The division of overheads into fixed, variable and semi-variable categories will help in determining overheads.

Determination of Standard Costs

How should the ideal standards for better controlling be determined?

1. Determination of Cost Centre

According to J. Betty, "A cost centre is a department or part of a department or an item of equipment or machinery or a person or a group of persons in respect of which costs are accumulated, and one where control can be exercised." Cost centres are necessary for determining the costs. If the whole factory is engaged in manufacturing a product, the factory will be a cost centre. In fact, a cost center describes the product while cost is accumulated. Cost centres enable the determination of costs and fixation of responsibility. A cost centre relating to a person is called personnel cost centre, and a cost centre relating to products and equipment is called impersonal cost centre.

2. Current Standards

A current standard is a standard which is established for use over a short period of time and is related to current condition. It reflects the performance that should be attained during the current period. The period for current standard is normally one year. It is presumed that conditions of production will remain unchanged. In case there is any change in price or manufacturing condition, the standards are also revised. Current standard may be ideal standard and expected standard.

3. Ideal Standard

This is the standard which represents a high level of efficiency. Ideal standard is fixed on the assumption that favourable conditions will prevail and management will be at its best. The price paid for materials will be lowest and wastes etc., will be minimum possible. The labour time for making the production will be minimum and rates of wages will also be low. The overhead expenses are also set with maximum efficiency in mind. All the conditions, both internal and external, should be favourable and only then ideal standard will be achieved.

Ideal standard is fixed on the assumption of those conditions which may rarely exist. This standard is not practicable and may not be achieved. Though this standard may not be achieved, even then an effort is made. The deviation between targets and actual performance is ignorable. In practice, ideal standard has an adverse effect on the employees. They do not try to reach the standard because the standards are not considered realistic.

4. Basic Standards

A basic standard may be defined as a standard which is established for use for an indefinite period which may be a long period. Basic standard is established for a long period and is not adjusted to the Present conditions. The same standard remains in force for a long period. These standards are revised only on the changes in specification of material and technology productions. It is indeed just like a number against which subsequent process changes can be measured. Basic standard enables the measurement of changes in costs. For example, if the basic cost for material is ₹ 20 per unit and the current price is ₹ 25 per unit, it will show an increase of 25% in the cost of materials. The changes in manufacturing costs can be measured by taking basic standard, as a base standard cannot serve as a tool for cost control purpose because the standard is not revised for a long time. The deviation between standard cost and actual cost cannot be used as a yardstick for measuring efficiency.

5. Normal Standards

As per terminology, normal standard has been defined as a standard which, it is anticipated, can be attained over a future period of time, preferably long enough to cover one trade cycle. This standard is based on the conditions which will cover a future period of five years, concerning one trade cycle. If a normal cycle of ups and downs in sales and production is 10 years, then standard will be set on average sales and production which will cover all the years. The standard attempts to cover variance in the production from one time to another time. An average is taken from the periods of recession and depression. The normal standard concept is theoretical and cannot be used for cost control purpose. Normal standard can be properly applied for absorption of overhead cost over a long period of time.

6. Organisation for Standard Costing

The success of standard costing system will depend upon the setting up of proper standards. For the purpose of setting standards, a person or a committee should be given this job. In a big concern, a standard costing committee is formed for this purpose. The committee includes production manager, purchase manager, sales manager, personnel manager, chief engineer and cost accountant. The cost accountant acts as a co-coordinator of this committee.

7. Accounting System

Classification of accounts is necessary to meet the required purpose, i.e. function, asset or revenue item. Codes can be used to have a speedy collection of accounts. A standard is a pre-determined measure of material, labour and overheads. It may be expressed in quality and its monetary measurements in standard costs.

Revision of Standards

For effective use of this technique, sometimes we need to revise the standards which follow for better control. Even standards are also subjected to change like the production method, environment, raw material, and technology.

Standards may need to be changed to accommodate changes in the organisation or its environment. When there is a sudden change in economic circumstances, technology or production methods, the standard cost will no longer be accurate. Standards that are out of date will not act as effective feed forward or feedback control tools. They will not help us to predict the inputs required nor help us to evaluate the efficiency of a particular department. If standards are continually not being achieved and large deviations or variances from the standard are reported, they should be carefully reviewed. Also, changes in the physical productive capacity of the organisation or in material prices and wage rates may indicate that standards need to be revised. In practice, changing standards frequently is an expensive operation and can cause confusion. For this reason, standard cost revisions are usually made only once a year. At times of rapid price inflation, many managers have felt that the high level of inflation forced them to change price and wage rate standards continually. This, however, leads to reduction in value of the standard as a yardstick. At the other extreme is the adoption of basic standard which will remain unchanged for many years. They provide a constant base for comparison, but this is hardly satisfactory when there is technological change in working procedures and conditions.

Summary

Basically, standard costing is a management tool for control. In the process, we have taken standards as parameters for measuring the performance. Cost analysis and cost control is essential for any activity. Cost includes material labour and overheads. Sometimes, we need to revise the standards due to change in uses, raw material, technology, method of production etc. For a proper organisation, it is required to implement this under a committee for the activity. It is a continued activity for the optimum utilisation of resources.

Variance Analysis

A variance is the difference between an actual result and an expected result. The process by which the total difference between standard and actual results is analysed is known as variance analysis. When actual results are better than the expected results, we have a favourable variance (F). If, on the other hand, actual results are worse than expected results, we have an adverse (A).

I will use this example throughout this Exercise:

Standard cost of Product A	₹
Materials (5 kgs × ₹10 per kg)	50
Labour (4 hrs × ₹5 per hr)	20
Variable o/hds (4 hrs × ₹2 per hr)	8
Fixed o/hds (4 hrs × ₹6 per hr)	24
	102

Budgeted results

Production:	1,200 units
Sales:	1,000 units
Selling price:	₹ 150 per unit

ACTUAL Results

Production:	1,000 units
Sales:	900 units
Materials:	4,850 kgs, ₹ 46,075
Labour:	4,200 hrs, ₹ 21,210
Variable o/hds:	₹ 9,450
Fixed o/hds:	₹ 25,000
Selling price:	₹ 140 per unit

1. Variable Cost Variances

Direct Material Variances

The direct material total variance is the difference between what the output actually cost and what it should have cost, in terms of material.

From the example above the material total variance is given by:

1,000 units should have cost ($\times ₹ 50$)	50,000
But did cost	46,075
Direct material total variance	3,925 (F)

It can be divided into two sub-variances

The Direct Material Price Variance

This is the difference between what the actual quantity of material used did cost and what it should have cost.

	₹
4,850 kgs should have cost ($\times ₹10$)	48,500
But did cost	46,075
Direct material price variance	2,425 (F)

The Direct Material Usage Variance

This is the difference between how much material should have been used for the number of units actually produced and how much material was used, valued at standard cost

1,000 units should have used ($\times 5$ kgs)	5,000 kgs
But did use	4,850 kgs
Variance in kgs	150 kgs (F)
Valued at standard cost per kg	$\times ₹10$
Direct material usage variance in ₹	₹ 1,500 (F)

The direct material price variance is calculated on material purchases in the period if closing stocks of raw materials are valued at standard cost or material used if closing stocks of raw materials are valued at actual cost (FIFO).

Direct Labour Total Variance

The direct labour total variance is the difference between what the output should have cost and what it did cost, in terms of labour.

	₹
1,000 units should have cost ($\times ₹ 20$)	20,000
But did cost	21,210
Direct material price variance	1,210 (A)

Direct Labour Rate Variance

This is the difference between what the actual number of hours worked should have cost and what it did cost.

	₹
4,200 hrs should have cost (4,200 hrs $\times ₹ 5$)	21,000
But did cost	21,210
Direct labour rate variance	210 (A)

The Direct Labour Efficiency Variance

This is the difference between how many hours should have been worked for the number of units actually produced and how many hours were worked, valued at the standard rate per hour.

₹	
1,000 units should have taken (x 4 hrs)	4,000 hrs
But did take	4,200 hrs
Variance in hrs	200 hrs
Valued at standard rate per hour	× ₹ 5
Direct labour efficiency variance	₹ 1,000 (A)

When idle time occurs the efficiency variance is based on hours actually worked (not hours paid for) and an idle time variance (hours of idle time x standard rate per hour) is calculated.

2. Variable Production Overhead Total Variances

The variable production overhead total variance is the difference between what the output should have cost and what it did cost, in terms of variable production overhead.

₹	
1,000 units should have cost (× ₹8)	8,000
But did cost	9,450
Variable production o/hd expenditure variance	1,450 (A)

The Variable Production Overhead Expenditure Variance

This is the difference between what the variable production overhead did cost and what it should have cost

₹	
4,200 hrs should have cost (× ₹ 2)	8,400
But did cost	9,450
Variable production o/hd expenditure variance	1,050 (A)

The Variable Production Overhead Efficiency Variance

This is the same as the direct labour efficiency variance in hours, valued at the variable production overhead rate per hour.

Labour efficiency variance in hours	200 hrs (A)
Valued @ standard rate per hour	× ₹ 2
Variable production o/hd efficiency variance	₹ 400 (A)

3. Fixed Production Overhead Variances

The total fixed production variance is an attempt to explain the under or overabsorbed fixed production overhead.

$$\text{Remember that overhead absorption rate} = \frac{\text{Budgeted fixed production overhead}}{\text{Budgeted level of activity}}$$

If either the numerator or the denominator or both are incorrect then we will have under or over-absorbed production overhead.

- If actual expenditure \pm budgeted expenditure (numerator incorrect) » expenditure variance
- If actual production/hours of activity » budgeted production/hours of activity (denominator incorrect) » volume variance.
- The workforce may have been working at a more or less efficient rate than standard to produce a given output » volume efficiency variance (similar to the variable production overhead efficiency variance).
- Regardless of the level of efficiency, the total number of hours worked could have been more or less than was originally budgeted (employees may have worked a lot of overtime or there may have been a strike and so actual hours worked were less than budgeted) » volume capacity variance.

4. The Fixed Production Overhead Variances are Calculated as Follows:

Fixed production overhead variance

This is the difference between fixed production overhead incurred and fixed production overhead absorbed (= the under or overabsorbed fixed production overhead):

	₹
Overhead incurred	25,000
Overhead absorbed (1,000 units \times ₹24)	24,000
Overhead variance	1,000 (F)

Fixed Production Overhead Expenditure Variance

This is the difference between the budgeted fixed production overhead expenditure and actual fixed production overhead expenditure

	₹
Budgeted overhead (1,200 \times ₹24)	28,800
Actual overhead	25,000
Expenditure variance	3,800 (F)

Fixed Production Overhead Volume Variance

This is the difference between actual and budgeted production volume multiplied by the standard absorption rate per unit.

	₹
Actual production at std. rate (1,000 \times ₹ 24)	24,000
Budgeted production at std. rate (1,200 \times ₹ 24)	28,800
	4,800 (A)

Fixed Production Overhead Volume Efficiency Variance

This is the difference between the number of hours that actual production should have taken, and the number of hours actually worked (usually the labour efficiency variance), multiplied by the standard absorption rate per hour.

Labour efficiency variance in hours	200 hrs (A)
Valued @ standard rate per hour	× ₹ 6
Volume efficiency variance	₹ 1,200 (A)

Fixed Production Overhead Volume Capacity Variance

This is the difference between budgeted hours of work and the actual hours worked, multiplied by the standard absorption rate per hour

Budgeted hours (1,200 x 4)	4,800 hrs
Actual hours	4,200 hrs
Variance in hrs	600 hrs (F)
x standard rate per hour	× ₹ 6
	₹ 3,600 (A)

KEY

The fixed overhead volume capacity variance is unlike the other variances in that an excess of actual hours over budgeted hours results in a favourable variance and not an adverse variance as it does when considering labour efficiency, variable overhead efficiency and fixed overhead volume efficiency. Working more hours than budgeted produces an overabsorption of fixed overheads, which is a favourable variance.

Sales Variances**5. Selling Price Variance**

The selling price variance is a measure of the effect on expected profit of a different selling price to standard selling price. It is calculated as the difference between what the sales revenue should have been for the actual quantity sold, and what it was.

	₹
Revenue from 900 units should have been (× ₹150)	135,000
But was (x ₹140)	126,000
Selling price variance	9,000 (F)

Sales Volume Variance

The sales volume variance is the difference between the actual units sold and the budgeted quantity, valued at the standard profit per unit. In other words it measures the increase or decrease in standard profit as a result of the sales volume being higher or lower than budgeted.

Budgeted sales volume	1,000 units
Actual sales volume	900 units

Variance in units	100 units (F)
x standard margin per unit (x ₹ (150 – 102))	× ₹ 48
Sales volume variance	₹ 4,800 (F)

KEY

Don't forget to value the sales volume variance at standard contribution marginal costing is in use.

Operating Statement

The most common presentation of the reconciliation between budgeted and actual profit is as follows.

	₹	₹
Budgeted profit before sales and admin costs	X	
Sales variances – price		X
– volume	X	X
Actual sales minus standard cost of sales		X
Cost variances	₹	₹
	(F)	(A)
Material price	X	
Material usage etc.	X	X
	X	X
Sales and administration costs	X	
Actual profit	X	

Variances in a Standard Marginal Costing System

- No fixed overhead volume variance
- Sales volume variances are valued at standard contribution margin (not standard profit margin)

Reasons, Interdependence and Significance**6. Reasons for Variances****Material Price**

- (F) unforeseen discounts received, greater care taken in purchasing, change in material standard.
 (A) price increase, careless purchasing, change in material standard.

Material Usage

- (F) material used of higher quality than standard, more effective use made of material.
 (A) defective material, excessive waste, theft, stricter quality control.

Labour Rate

- (F) use of workers at rate of pay lower than standard.
- (A) wage rate increase.

Idle Time

Machine breakdown, non-availability of material, illness.

Labour Efficiency

- (F) output produced more quickly than expected because of work motivation, better quality of equipment or materials.
- (A) lost time in excess of standard allowed, output lower than standard set because of deliberate restriction, lack of training, substandard material used.

Overhead Expenditure

- (F) savings in cost incurred, more economical use of services.
- (A) increase in cost of services used, excessive use of services, change in type of services used

Overhead Volume

- (F) production greater than budgeted
- (A) production less than budgeted

7. Interdependence between Variances

The cause of one (adverse) variance may be wholly or partly explained by the cause of another (favourable) variance.

- Material price or material usage and labour efficiency
- Labour rate and material usage
- Sales price and sales volume

8. The Significance of Variances

The decision as to whether or not a variance is so significant that it should be investigated should take a number of factors into account.

- The type of standard being used
- Interdependence between variances
- Controllability
- Materiality

9. Materials Mix and Yield Variances

The materials usage variance can be subdivided into a materials mix variance and a materials yield variance if the proportion of materials in a mix is changeable and controllable.

The mix variance indicates the effect on costs of changing the mix of material inputs.

The yield variance indicates the effect on costs of material inputs yielding more or less than expected.

Standard input to produce 1 unit of product X:

		₹
Material A	20 kgs × ₹ 10	200
Material B	30 kgs × ₹ 5	150
		<u>350</u>

In period 3, 13 units of product X were produced from 250 kgs of material A and 350 kgs of material B.

Solution 1: individual prices per kg as variance valuation cases

Mix Variance

		Kgs
Standard mix of actual use:	A: $2/5 \times (250+350)$	240
	B: $3/5 \times (250+350)$	360
		<u>600</u>
	A	B
Mix should have been	240 kgs	360 kgs
But was	250 kgs	350 kgs
Mix variance in kgs	10 kgs (A)	10 kgs (F)
x standard cost per kg	x ₹10	x ₹5
Mix variance in ₹	<u>₹100 (A)</u>	<u>₹50 (F)</u>
	50 (A)	

Total mix variance in quantity is always zero.

Yield variance

	A	B
13 units of product X should have used	260 kgs	390 kgs
but actual input in standard mix was	240 kgs	360 kgs
Yield variance in kgs	20 kgs (F)	30 kgs (F)
x standard cost per kg	× ₹ 10	× ₹ 5
	<u>₹ 200 (F)</u>	<u>₹ 150 (F)</u>
	<u>₹ 350 (F)</u>	

Solution 2: Budgeted weighted average price per unit of input as variance valuation base.

Therefore, Budgeted weighted average price = ₹ 350/50 = ₹ 7 per kg

Mix variance

	A	B
13 units of product X should have used	260 kgs	390 kgs
but did use	250 kgs	350 kgs
Usage variance in kgs	10 kgs (F)	40 kgs (F)

x individual price per kg – budgeted		
weighted average price per kg		
₹ (10 – 7)	× ₹ 3	
₹ (5 – 7)		× (₹ 2)
	<u>₹ 30 (F)</u>	<u>₹ 80 (A)</u>
	<u>₹ 50 (A)</u>	
Yield variance		
	A	B
Usage variance in kgs	10 kg (F)	40 kg (F)
x budgeted weighted average		
Price per kg	₹ 7	× ₹ 7
	<u>₹ 70 (F)</u>	<u>₹ 280 (F)</u>
	<u>₹ 350 (F)</u>	

1. Verification tree for sales variance

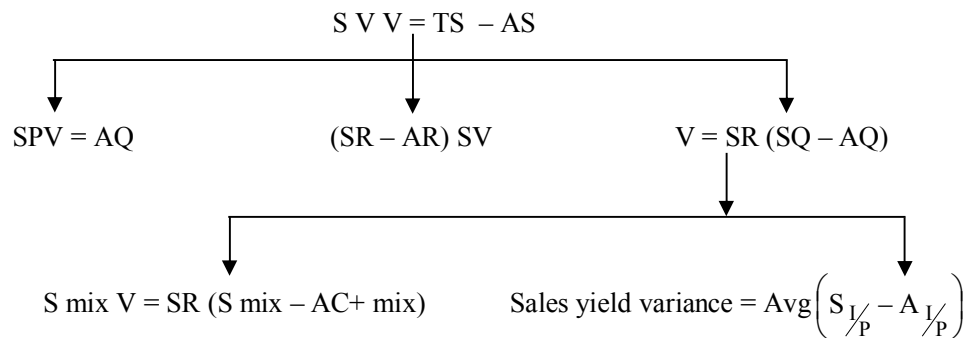

2. Verification tree for material variance

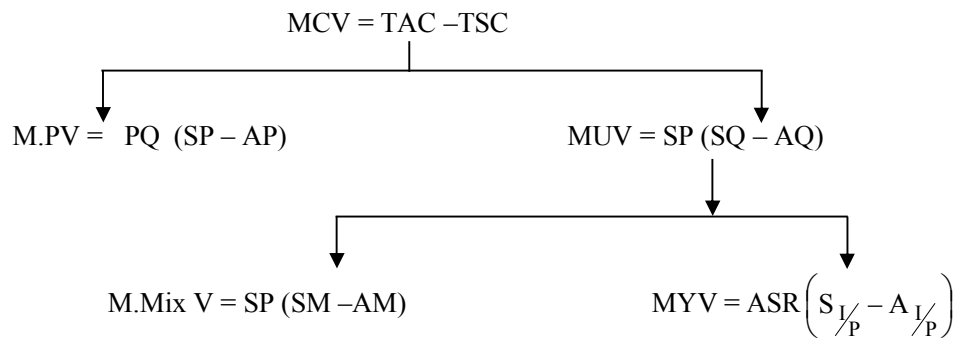

Same as material variance even Labour variance can be verified.

10. Sales Mix and Quantity Variances

The sales volume variance can be subdivided into a mix variance if the proportions of products sold are controllable.

Sales Mix Variance

This variance indicates the effect on profit of changing the mix of actual sales from the standard mix.

It can be calculated in one of two ways.

The difference between the actual total quantity sold in the standard mix and the actual quantities sold, valued at the standard margin per unit.

The difference between actual sales and budgeted sales, valued at (standard profit per unit – budgeted weighted average profit per unit).

Sales Quantity Variance

This variance indicates the effect on profit of selling a different total quantity from the budgeted total quantity.

It can be calculated in one of two ways.

- The difference between actual sales volume in the standard mix and budgeted sales valued at the standard margin per unit.
- The difference between actual sales volume and budgeted sales valued at the budgeted weighted average profit per unit.

KEY

With all variance calculations, from the most basic (such as variable cost variances) to the more complex (such as mix and yield/mix and quantity variances), it is vital that you do not simply learn formulae. You must understand what your calculations are supposed to show.

Illustrations

Illustration 1: 'X' Ltd. has budgeted the following sales for the month of August, 2012.

Product	No. of units	Selling Price per Unit (₹)
A	15,000	15.00
B	9,000	20.00
C	12,000	12.00

The Actual sales for the month of August 2012 were as follows:

Product	No. of units	Selling Price per Unit (₹)
A	16,500	14.00
B	10,000	19.50
C	12,300	11.90

You are required to calculate:

- Sales value variance
- Sales price variance
- Sales volume variance

- (d) Sales mix variance
 (e) Sales quantity variance

[CA, CWA Modified]

Solution:**Budgeted Sales**

Product	No. of units	S.P. per Unit (₹)	₹
A	15,000	15.00	2,25,000
B	9,000	20.00	1,80,000
C	12,000	12.00	1,44,000
	36,000		5,49,000

Actual Sales

Product	No. of units	S.P. per Unit (₹)	₹
A	16,500	14.00	2,31,000
B	10,000	19.50	1,95,000
C	12,300	11.90	1,46,370
	38,800		5,72,370

$$\text{Revised Std. Qty.} = \frac{\text{Total Budget Qty.}}{\text{Total Actual Qty.}} \times \text{Budget Qty.}$$

$$A = \frac{36,000}{38,800} \times 15,000 = 13,917$$

$$B = \frac{36,000}{38,800} \times 9,000 = 8,350$$

$$C = \frac{36,000}{38,800} \times 12,000 = 11,134$$

Revised sales as are follows:

Product	Revised Qty.	Budget Price	Revised Sales
A	13,917	15.00	2,08,755
B	8,350	20.00	1,67,000
C	11,134	12.00	1,33,608
	33,401		5,09,363

Applied sales as are follows:

Product	Actual Qty.	Budget Price	Applied Sales
A	16,500	15.00	2,47,500
B	10,000	20.00	2,00,000

C	12,300	12.00	1,47,600
	38,800		5,95,100

(a) Sales Value variance

= Budget Sales – Actual Sales

= 5,49,000 – 5,72,370

= ₹ 23,370 (F)

(b) Sales Price variance

= Applied Sales – Actual Sales

= 5,95,100 – 5,72,370

= ₹ 22,730 (A)

(c) Sales Volume variance

= Budget Sales – Actual Sales

= 5,49,000 – 5,95,100

= ₹ 46,100 (F)

(d) Sales Mix variance

= Revised Sales – Actual Sales

= 5,09,363 – 5,95,100

= ₹ 85,737 (F)

(e) Sales Quantity variance

= Budgeted Sales – Revised Sales

= 5,49,000 – 5,09,363

= ₹ 39,637 (A)

Illustration 2: The Following particulars are available in respect of the working of a company for a particular period:

Product	Budgeted Sales			Actual Sales		
	Quantity (Units)	Price (₹)	Amt (₹)	Quantity (Units)	Price (₹)	Amt (₹)
A	1,000	2	2,000	1,800	2.50	4,500
B	3,000	3	9,000	4,200	2.75	11,550
Total	4,000		11,000	6,000		16,050

You are required to calculate:

- (1) Total Sales volume Variance
- (2) Sales Price variance
- (3) Sales Mix Variance and
- (4) Sales Quantity Variance

[M.Com. Modified]

Solution:

- (1) Sales price Variance = ASQ (ASP – BSP)
 A: 1,800 (2.5 – 2) = 900 F
 B: 4,200 (2.75 – 3) = 1,050 A
 Total = 150 A
- (2) Sales Volume Variance = BSP (ASQ – BSQ)
 A: 2 (1,800 – 1,000) = 1,600 F

$$\begin{aligned}
 & \text{B: } 3(4,200 - 3,000) &= & 3,600 \text{ F} \\
 & \text{Total} &= & 5,200 \text{ F} \\
 (3) \text{ Sales Quantity Variance} &= & \text{BSP (RSSQ - BSQ)} \\
 & \text{A: } \left(2 \times \left[\frac{1000}{4000} \times 6000 \right] - 2000 \right) &= & 1,000 \text{ F} \\
 & \text{B: } \left(3 \times \left[\frac{3000}{4000} \times 6000 \right] - 9000 \right) &= & 4,500 \text{ F} \\
 & \text{Total} &= & 5,500 \text{ F} \\
 (4) \text{ Sales Mix Variance} &= & \text{BSP (ASQ - RSSQ)} \\
 & \text{A: } \left(2 \times 1800 - \left[\frac{1,000}{4,000} \times 6,000 \right] \right) &= & 600 \text{ F} \\
 & \text{B: } \left(3 \times 4200 - \left[\frac{3,000}{4,000} \times 6,000 \right] \right) &= & 900 \text{ A} \\
 & \text{Total} &= & 300 \text{ A}
 \end{aligned}$$

Illustration 3: Following data is available of Devansh:

Budgeted Sales:

X 500 units @ ₹ 5 per unit

Y 700 units @ ₹ 8 per unit

Actual Sales:

X 635 @ ₹ 5.4 per unit

Y 865 @ ₹ 8.2 per unit

Calculate all Sales Variances:

[CS Modified]

Solution:

Products	SQ	SR	SC	AQ	AR	AC	RSQ
X	500	5	2,500	635	5.4	3,429	$\frac{500}{1200} \times 1500 = 625$
Y	700	8	5,600	865	8.2	7,093	$\frac{700}{1200} \times 1500 = 875$
Total	1,200	-	8,100	1,500	-	10,522	1,500

$$\begin{aligned}
 (1) \text{ Sales Value Variances} &= (\text{AR X AQ}) - (\text{SR X SQ}) \\
 &= 10,522 - 8,100 = 2,422 \text{ A} \\
 (2) \text{ Sales Price Variance} &= \text{AQ}(\text{ASP} - \text{BSP}) \\
 & \quad \text{X} &= 635(5.4 - 5) = 254 \text{ F} \\
 & \quad \text{Y} &= 865(8.2 - 8) = 173 \text{ A}
 \end{aligned}$$

	=	427 A
(3) Sales Volume Variance	=	BSP(AQ – BQ)
X	=	5(635 – 500) = 675 A
Y	=	8(865 – 700) = 1320 A
	=	1995A
(4) Sales Mix Variance	=	BSP(AQ – RSQ)
X	=	5(635 – 625) = 50 A
Y	=	8(865 – 875) = 80 F
	=	30 F
(5) Sales Quantity Variance	=	BSP(RSQ – BQ)
X	=	5(625 – 500) = 625 A
Y	=	8(875 – 700) = 1400 A
	=	2025 A

Illustration 4: Compute the Missing Data indicated by question marks from the following:

Particulars	Product R	Product S
Sales Quantity (Std.)	?	400
Actual (Units)	500	?
Price/Unit Std.	12	15
Price/Unit – Actual	15	20
Sales price Variance	?	?
Sales Volume Variance	1200 F	?
Sales Value Variance	?	?

Sales Mix Variance for both the products together is ₹ 450 (F)

[CMA & CS Modified]

Solution:

Product	Standard Quality	Standard price	Actual Quantity	Actual Price	RSQ
R	400	12	500	15	$\frac{400}{800} \times 1300 = 650$
S	400	15	800	20	
	800		1300		$\frac{400}{800} \times 1300 = 650$
					1300

(1) Sales Revenue variance ASR – BSR

R: $(500 \times 15) - (400 \times 12)$

7500 – 4800 = 2,700 F

S: $(800 \times 20) - (400 \times 15)$

16,000 – 6,000 = 10,000 F

= 12,700 F

- (2) Sales Price Variance = ASQ (ASP – SSP)
 R: 500 (15 – 12) = 1,500 F
 S: 800 (20 – 15) = 4,000 F
 = 5,500 F
- (3) Sales Volume Variance = SSP (ASQ – SSQ)
 R: 12 (500 – 400) = 1,200 F
 S: 15 (800 – 400) = 6,000 F
 = 7,200 F
- (4) Sales Mix Variance = SSP (ASQ – RSQ)
 R: 12 (500 – 650) = 1,800 A
 S: 15 (800 – 650) = 2,250 F
 450 F
- (5) Sales Quantity Variance = (RSSQ – SSQ) SSP
 R: (650 – 400) 12 = 3,000 F
 S: (650 – 400) 15 = 3,750 F
 = 6,750 F
- (6) R: 12 [500 – (250 + 0.5x)] =
 S: 15 [x – (250 + 0.5X)] =
 [12 (500 – 250 – 0.5x)] + [15 (x – 250 – 0.5x)] = 450
 [12 (250 – 0.5x)] + [15(0.5x – 250)] = 450
 [3,000 – 6x] + [7.5x – 3,750] = 450
 3,000 – 3,750 – 6x + 7.5x = 450
 –750 + 1.5x = 450
 1.5 x = 450 + 750
 X = 800

Illustration 5: Vinay Ltd. produces an article by blending three basic raw materials. It operates a standard costing system and the following standards have been set for materials.

Materials	Standard Mix (%)	Standard Price per kg ₹
A	25	8.80
B	35	10.60
C	40	12.90

The standard loss in processing is 20%

During the month of August, 2012, Company produced 12,000 kgs. of finished output.

The actual consumption of materials is as under:

Materials	Quantity (kgs.)	Actual Price per kg ₹
A	3600	8.70
B	5200	10.80
C	5900	13.10

You are required to calculate:

- (a) Material Cost variance
- (b) Material Price variance
- (c) Material Usage variance
- (d) Material Mix variance
- (e) Material Yield variance

[M. Phil Modified]

Solution:

(a) Material price variance

	= Actual Qty used (Std price – Actual price)	
Material A	= 3600 (8.80 – 8.70)	
	= 3600 (0.10)	= ₹ 360 (F)
Material B	= 5200 (10.60 – 10.80)	
	= 5200 (0.20)	= ₹ 1040 (A)
Material C	= 5900 (12.90 – 13.10)	
	= 5900 (0.20)	= ₹ 1180 (A)

(b) Material cost variance

	= (Std. Price × Std. Qty) – (Actual Price × Actual Qty)	
Material A	= (8.80 × 3000) – (8.70 × 3600)	
	= 26,400 – 31,320	= ₹ 4920 (A)
Material B	= (10.60 × 4200) – (10.80 × 5200)	
	= 44,520 – 56,160	= ₹ 11,640 (A)
Material C	= (12.90 × 4800) – (13.10 × 5900)	
	= 61,920 – 77,290	= ₹ 15,370 (A)

Revised Std. Qty.

Material A	= $\frac{25}{100} \times 14700$	= 3675
Material B	= $\frac{35}{100} \times 14700$	= 5145
Material C	= $\frac{40}{100} \times 14700$	= 5880

(c) Material Mix variance

	= Std price (Revised Std. Qty. – Actual Qty.)	
Material A	= 8.80 (3675 – 3600)	
	= 8.80 (75)	= ₹ 660 (F)

Material B	= 10.60 (5145 – 5200)	
	= 10.60 (55)	= ₹ 583 (A)
Material C	= 12.90 (5880 – 5900)	
	= 12.90 (20)	= ₹ 258 (A)

(d) Material Usage variance

= Std. Price (S.Q. for actual output – Actual qty. used)

A	= $\frac{25}{100} \times 12000$	= 3000
B	= $\frac{35}{100} \times 12000$	= 4200
C	= $\frac{40}{100} \times 12000$	= 4800
Material A	= 8.80 (3000 – 3600)	
	= 8.80 (600)	= ₹ 5280 (A)
Material B	= 10.60 (4200 – 5200)	
	= 10.60 (1000)	= ₹ 10,600 (A)
Material C	= 12.90 (4800 – 5900)	
	= 12.90 (1100)	= ₹ 14,190 (A)

(e) Material Yield variance

= Std. cost per unit of output (Std. yield for actual material – Actual yield)

$$A = 8.80 (3,000 - 3,675) = 5,940 \text{ (A)}$$

$$B = 10.60 (4,200 - 5,145) = 10,017 \text{ (A)}$$

$$C = 12.90 (4,800 - 5,880) = 13,932 \text{ (A)}$$

Illustration 6: The Standard material cost for a normal mix of one tonne of Chemical X is based on:

Chemical:	X	Y	Z
Usage (Kg.):	240	400	640
Price per (Kg.) (₹):	6	12	10

During a month, 6.25 tonnes of X were purchased from.

Chemical:	X	Y	Z
Consumption (Tonnes):	1.6	2.4	4.5
Cost (₹):	11,200	30,000	47,250

Calculate the material variances

[M.Com. & M.Phil Modified]

Solution:

Chemical	SQ	SP	AQ	*AP		RSQ
X	1,500	6	1,600	<u>11,200</u>	7	$\frac{1,500}{8,000} \times 8,500 = 1,593.75$
Y	2,500	12	2,400	<u>30,000</u>	12.5	$\frac{2,500}{8,000} \times 8,500 = 2,656.25$
Z	4,000	10	4,500	<u>47,250</u>	10.5	$\frac{4,000}{8,000} \times 8,500 = 4,250.00$
				<u>4,500</u>		
Total	8,000	-	8,500	-	-	8,500

Actual Output

Note: 1,000 kgs = 1 tonne

- *Actual Price (AP) = Actual Cost/Actual Quantity {(/) Divide}
- (a) Material Cost Variance = (SQ × SP) – (AQ × AP)
- X: (1,500 × 6) – 11,200
 9,000 – 11,200 = 2,200 A
- Y: (2,500 × 12) – 30,000
 30,000 – 30,000 = Zero
- Z: (4,000 × 10) – 47,250
 40,000 – 47,250 = 7,250 A
- Total** = **9,450 A**
- (b) Material Price Variance = AQ (SP – AP)
- X: 1,600 (6 – 7) = 1,600 A
- Y: 2,400 (12 – 12.5) = 1,200 A
- Z: 4,500 (10 – 10.5) = 2,250 A
- Total** = **5,050 A**
- (c) Material Usage Variance = SP (SQ – AQ)
- X: 6 (1,500 – 1,600) = 600 A
- Y: 12 (2,500 – 2,400) = 1,200 F
- Z: 10 (4,000 – 4,500) = 5,000 A
- Total** = **4,400 A**
- (d) Material Mix Variance = SP (RSQ – AQ)
- 6 (1593.75 – 1600) = 37.5 A
- 12 (2656.25 – 2400) = 3075 F
- Z: 10 (4,250 – 4,500) = 2,500.00 A
- Total** = **537.50 F**
- (e) Material yield Variance = SP (SQ – RSQ)
- X: 6 (1,500 – 1,593.75) = 562.50 A

Y: 12 (2,500 – 2,656.25)	=	1,875.00 A
Z: 10 (4,000 – 4,250)	=	<u>2,500.00 A</u>
Total	=	<u>4,937.50 A</u>

Illustration 7: A gang of workers normally consists of 30 men, 15 women and 10 boys. They are paid at Standard rates per hour as, Men ₹ 80.00 women ₹ 60.00 and Boy ₹ 40.00. In a normal working of a week of 40 hours, the Gang is expected to produce 2000 units of output.

During the week ended 31st December, 2011, the gang consisted of 40 men, 10 women and 05 boys. The actual wages paid per hour were Men ₹ 70.00, Women ₹ 65.00 and Boy ₹ 30.00. Actual units produced by the gang 1600 units.

Calculate:

- (i) Labour Cost Variance
- (ii) Labour Rate Variance
- (iii) Labour Efficiency Variance
- (iv) Labour Mix Variance
- (v) Labour Yield Variance

[M. Com & T.Y. BAF Modified]

Solution:

(i) Labour Cost Variance

(Std. Rate × Std. time for actual output) – (Actual Rate × Actual Time)

Men	=	(80 × 960) – (70 × 1600)	
	=	(76,800 – 1,12,000)	= ₹ 35,200 (A)
Women	=	(60 × 480) – (65 × 400)	
	=	(28,800 – 26,000)	= ₹ 2,800 (F)
Boys	=	(40 × 320) – (30 × 200)	
	=	(12,800 – 6,000)	= ₹ 6,800 (F)
Labour Cost Variance			₹ 25,600 (A)

(ii) Labour Rate Variance

Actual time (SR – AR)

Men	=	1600 (80 – 70)	= ₹ 16,000 (F)
Women	=	400 (60 – 65)	= ₹ 2,000 (A)
Boys	=	200 (40 – 30)	= ₹ 2,000 (F)
Labour Rate Variance			₹ 16,000 (F)

(iii) Labour Efficiency Variance

= Std. price (Std. time for actual output – actual time)

Men	=	80 (960 – 1600)	
	=	80 (640)	= ₹ 51,200 (A)
Women	=	60 (480 – 400)	

	=	60 (80)	=	₹ 4,800 (F)
Boys	=	40 (320 – 200)		
	=	40 (120)	=	₹ 4,800 (F)
		Labour Efficiency Variance		₹ 41,600 (A)

(iv) Labour Mix Variance

	=	Std. Rate (Std. Time – Actual Time Worked)		
Men	=	80 (1200 – 1600)		
	=	80 (400)	=	₹ 32,000 (A)
Women	=	60 (600 – 400)		
	=	60 (200)	=	₹ 12,000 (F)
Boys	=	40 (400 – 200)		
	=	40 (200)	=	₹ 8,000 (F)
		Labour Mix Variance		₹ 12,000 (A)

(v) Labour Yield Variance

	=	Std. labour cost per unit of output × (Std. Output for Actual Time – Actual output)		
	=	74 (2000 – 1600)		
	=	74 (400)	=	₹ 29,600 (F)

Working Notes:**1. Actual time**

Men	=	40 × 40	=	1600
Women	=	10 × 40	=	400
Boys	=	05 × 40	=	200
				2200 hrs.

2. Std. time for actual output

Men	=	$\frac{1600}{2000} \times (30 \times 40)$	=	960 hrs.
Women	=	$\frac{1600}{2000} \times (15 \times 40)$	=	480 hrs.
Boys	=	$\frac{1600}{2000} \times (10 \times 40)$	=	320 hrs.

3. Std. time

Men	=	(30 × 40)	=	1200 hrs.
Women	=	(15 × 40)	=	600 hrs.
Boys	=	(10 × 40)	=	400 hrs.

4. Std. labour cost permit of output:

Std. output given = 2000 units

Std. Cost given

Men	=	30 × 40 × 80	=	96000
Women	=	15 × 40 × 60	=	36000
Boys	=	10 × 40 × 40	=	16000
				1,48,000

So, labour cost permit of output

$$= \frac{1,48,000}{2000} = ₹ 74/-$$

Std. output for actual time worked for 2200 hours of total.

Std. output = 2000 units

for 1760 hrs. of actual time worked

$$= 2000 \times \frac{1760}{2200} = 1600 \text{ units}$$

Illustration 8: The Devansh Ltd. manufactures a particular product, the standard direct labour cost of which is ₹ 120 and which is arrived as follows:

Grade of Workers	Hours per unit of Output	Rate per hour (₹)	Amount (₹)
X	30	2	60
Y	20	3	60
Total	50		120

In a particular period, 100 units of the product were produced, the actual cost of which was as follows:

Grade of Workers	Hours	Rate (₹)	Amount (₹)
X	3,200	1.50	4,800
Y	1,900	4.00	7,600
Total	5,100		12,400

You are required to calculate the:

- (1) Total Labour cost variance
- (2) Labour rate variance
- (3) Labour mix variance and
- (4) Labour efficiency variance

Solution: Standard Input for Actual Output

[CMA & CS Modified]

Grade of Workers	SH	SR	AH	AR	RSH
X	3,000	2	3,200	1.5	$\frac{3,000}{5,000} \times 5,100 = 3,060$
Y	2,000	3	1,900	4	$\frac{2,000}{5,000} \times 5,100 = 2,040$
Total	5,000	-	5,100	-	5,100

Grade of Workers	Per Unit	For 100 Units
A	30	3,000
B	20	2,000
Total	50	5,000

Labour Cost variance = $(SH \times SR) - (AH \times AR)$

A: $(3,000 \times 2) - 4,800$

$6,000 - 4,800 = 1,200$ F

B: $(2,000 \times 3) - 7,600$

$6,000 - 7,600 = 1,600$ A

Total = 400 A

Labour Rate Variance = $AH (SR - AR)$

A: $3,200 (2 - 1.5) = 1,600$ F

B: $1,900 (3 - 4) = 1,900$ A

Total = 300 A

Labour Efficiency variance = $SR (SH - AH)$

A: $2 (3,000 - 3,200) = 400$ A

B: $3 (2,000 - 1,900) = 300$ F

Total = 100 A

Labour Mix variance = $SR (RSH - AH)$

A: $2 (3,060 - 3,200) = 280$ A

B: $3 (2,040 - 1,900) = 420$

Total = 140 F

Illustration 9: Following Data is available from the records of a manufacturing company:

Standard (Per Unit)

Materials: 6 kg @ ₹ 4 per Kg

Labour: 4 Hours @ ₹ 4 per hour

Standard Production For the Month: 12,000 units

Actual Production For the Month:	12,500 units
Actual Material price per kg.	₹ 4.50
Material Consumed during the month:	7,800 Kg
Direct labour hours worked:	48,000 hours
Actual Wage rate per hour:	₹ 3.50

Calculate:

- (1) Material Cost Variance
- (2) Material price Variance
- (3) Material Usage Variance
- (4) Labour Cost Variance
- (5) Labour Rate Variance
- (6) Labour Efficiency Variance

[M.Com. & M. Phil Modified]

Solution:

- (1) Material Cost variance = (SR X SQ) – (AR X AQ)
 Standard Cost – Actual Cost
 $(24 \times 12,000) - (7,800 \times 4.50)$
 $2,88,000 - 35,100$
 $= 2,52,900 \text{ F}$
 $SR = 6 \times 4 = ₹ 24$
- (2) Material Price Variance = AQ (SP – AP)
 $7,800 (4 - 4.50)$
 $= 3,900 \text{ A}$
- (3) Material Usage Variance SP (SQ – AQ)
 $4 (72,000 - 7,800)$
 $= 2,56,800 \text{ F}$
- (4) Labour Cost Variance = (SR x SH) – (AR x AH)
 Standard Labour Cost = Actual Labour Cost
 $(4 \times 4 \times 12,000) = (48,000 \times 3.50)$
 $= 1,92,000 - 1,68,000$
 $= 24,000 \text{ F}$
- (5) Labour Rate Variance AH (SR – AR)
 $48,000 (4 - 3.50)$
 $= 24,000 \text{ F}$
- (6) Labour Efficiency Variance = SR (SH – AH)
 $4 ([4 \times 12,000] - 48,000)$
 $4 (48,000 - 48,000)$
 $= \text{Zero}$

Illustration 10: The Following details relating to a product are made available to you:

Standard Cost per unit:

Materials: 50 Kg @ ₹ 40 per kg.

Labour: 400 hours @ Re. 1 per hour.

Actual Cost: (For an output of 10 units)

Material: 590 Kg @ ₹ 42 per kg

Labour: 3,960 hours @ ₹ 1.10 per unit

Calculate the Following Variances:

- (1) Material Cost Variance
- (2) Material Usage Variance
- (3) Material Price Variance
- (4) Labour Cost Variance
- (5) Labour Efficiency Variance
- (6) Labour rate Variance

[M.Com. & Modified]

Solution:

- (1) Material Cost Variance = $(SR \times SQ) - (AR \times AQ)$
 Standard Cost – Actual Cost
 $(40 \times 50 \times 10) - (42 \times 590)$
 $20,000 - 24,780$
 $= 4,780 \text{ A}$
- (2) Material Usage Variance = $SR (SQ - AQ)$
 $40 (50 \times 10 - 590)$
 $40 (500 - 590)$
 $= 3,600 \text{ A}$
- (3) Material Price Variance = $AQ (SR - AR)$
 $590 (40 - 42)$
 $= 1,180 \text{ A}$
- (4) Labour Cost Variance = $(SR \times SH) - (AR \times AH)$
 $(1 \times 400 \times 10) - (1.10 \times 3,960)$
 $4,000 - 4,356$
 $= 356 \text{ A}$
- (5) Labour Efficiency Variance = $SR (SH - AH)$
 $1 (400 \times 10 - 3,960)$
 $= 40 \text{ F}$
- (6) Labour rate Variance = $AH (SR - AR)$
 $3,960 (1 - 1.1)$
 $= 396 \text{ A}$

Illustration 11: The Following Standards have been set to manufacture a product.

Particulars	₹	₹
Direct materials:		
4 units of X @ ₹ 4 per unit	16	
6 units of Y @ ₹ 3 per unit	18	
Standard Material Cost		34
Direct Labour:		
3 Hours @ ₹ 2 per unit		6
Standard Cost per Unit		40

The Company manufactured and sold 6,000 units of the product during the year, details of direct material and labour cost being:

	₹	₹
Direct materials		
25,000 units of X @ ₹ 4.20 per unit	1,05,000	
36,000 units of Y @ ₹ 2.7 per unit	97,200	2,02,200
Direct labour:		
17,000 hours per @ 2.20 per hour		37,400
Total ₹		2,39,600

Calculate the Following Variances:

- (1) Material Cost Variance
- (2) Material usage Variance
- (3) Material Price Variance
- (4) Labour Cost Variance
- (5) Labour Efficiency Variance
- (6) Labour Rate Variance

[T.Y.BAF & M.Com. Modified]

Solution:

Basic calculations:

(1) Material:

Material	S	Q	SP	SC	AQ	AP	AC	RSQ
X	24,000		4	96,000	25,000	4.2	1,05,000	$\frac{24,000}{60,000} \times 61,000 = 24,400$
Y	36,000		3	1,08,000	36,000	2.7	97,200	$\frac{36,000}{60,000} \times 61,200 = 36,600$
Total	60,000		-	2,04,000	61,000	-	2,02,200	61,000

Actual Output 6,000 unitsX $4 \times 6,000 = 24,000$ unitsY $6 \times 6,000 = \underline{36,000}$ units
60,000 units**(2) Labour:**

SH	SR	SC	AH	AR	AC
18,000	2	36,000	17,000	2.2	37,400

- (1) Material Cost Variance = Standard Cost – Actual Cost
= SC – AC
X = $96,000 - 1,05,000 = 9,000$ A
Y = $1,08,000 - 97,200 = 10,800$ F
= 1,800 F
- (2) Material Usage Variance = SR (SO – AQ)
X = 4 (24,000 – 25,000) = 4,000 A
Y = 3 (36,000 – 36,000) = 0
= 4,000 A
- (3) Material Price Variance = AQ(SR – AR)
X = $25,000(4 - 4.2) = 5,000$ A
Y = $36,000(3 - 2.7) = 10,800$ F
= 5,800 F
- (4) Labour Cost Variance = $(SR \times SH) - (AR \times SH)$
= SC – AC
= $36,000 - 37,400 = 1,400$ A
- (5) Labour Efficiency Variance = SR (SH – AH)
= $2(18,000 - 17,000) = 2,000$ F
- (6) Labour Rate Variance = AH (SR – AR)
= $17,000(2 - 2.2) = 3,400$ A

Illustration 12: The Standard Cost of the product 'SLR' reveals:**Standard materials:**

	₹
2 kg of A @ ₹ 2 per kg	400
1 kg of B @ ₹ 6 per kg	600
Direct Labour (3 hours @ ₹ 6 per hour)	18.00

Actual Data:

	₹
Direct Materials	
19,000 kg of A @ 2.20 per kg	41,800
10,000 kg of B @ 5.60 per kg	56,000
Direct labour:	
(28,500 hours @ ₹ 6.40 per hour)	1,82,400

Actual Production was 9,000 units.

Calculate:

- (1) Material Price Variance
- (2) Material usage Variance
- (3) Material Cost Variance
- (4) Labour rate Variance
- (5) Labour Efficiency Variance.

[M.Com. & M.Phil Modified]

Solution:**(a) Material**

Standard Quantity for Actual output

Kgs.

$$A \ 2\text{kg} \times 9,000 = 18,000$$

$$B \ 1\text{kg} \times 9,000 = 9,000$$

$$= 27,000$$

Material	SR	SQ	SP	AR	AQ	AP	RSQ
A	2	18,000	36,000	2.2	19,000	41,800	19,333
B	6	9,000	54,000	5.6	10,000	56,000	9,667
Total	-	27,000	90,000	-	29,000	97,800	29,000

- (1) Material Cost variance = (SR X SQ) – (AR X AQ)
 - A = 36,000 – 41,000 = 5,800 A
 - B = 54,000 – 56,000 = 2,000 A
 - = 7,800 A
- (2) Material Price Variance = AQ (SR – AR)
 - A = 19,000 (2-2.2) = 3,800 A
 - B = 10,000 (6-5.6) = 4,000 F
 - = 200 F
- (3) Material Usage Variance = SR (SR – AR)
 - A = 2(18,000 – 19,000) = 2,000 A
 - B = 6(9,000 – 10,000) = 6,000 A
 - = 8,000 A

$$\begin{aligned}
 (4) \text{ Labour Rate Variance} &= AH (SR - AR) \\
 &= 28,500 (6-6.4) \\
 &= 11,400 \text{ A} \\
 (5) \text{ Labour Efficiency Variance} &= SR (SH - AH) \\
 &= 6(27,000 - 28,500) \\
 &= 9,000 \text{ A}
 \end{aligned}$$

(b) Labour:

SH	SR	SC	AH	AR	AC
27,000	6	1,62,000	28,500	6.4	1,82,400

Illustration 13: In Order to produce 20 kgs. Of finished goods, raw materials of 50 kgs are required at ₹ 2.10 per unit. During an accounting period 20 units are manufactured by employing 57 kgs of raw materials at the rate of ₹ 1.80.

Calculate material variances

[CS Modified]

Solution:

$$\begin{aligned}
 (1) \text{ Material Cost Variance} &= (SR \times SQ) - (AR \times AQ) \\
 &= (2.10 \times 50) - (1.80 \times 57) \\
 &= 105 - 102.6 \\
 &= 2.4 \text{ F} \\
 (2) \text{ Material Price Variance} &= AQ (SR - AR) \\
 &= 57(2.10 - 1.80) \\
 &= 17.1 \text{ F} \\
 (3) \text{ Material Usage Variance} &= SR(SQ - AQ) \\
 &= 2.10(50 - 57) \\
 &= 14.7 \text{ A}
 \end{aligned}$$

Illustration 14: Following data pertains to Mahi Ltd.

Materials	Standard Quantity	Standard Rate (₹)	Actual Quantity	Actual Rate (₹)
X	40	50	50	45
Y	60	40	60	55

Calculate Material Variances

[T.Y.B.Com. Modified]

Solution:

Materials	SQ	SR	AQ	AR	RSQ
X	40	50	50	45	$\frac{40}{110} \times 110 = 44$
Y	60	40	60	55	$\frac{60}{110} \times 110 = 66$
Total	100	-	110	-	110

(1) Material Cost Variance	=	(SR X SQ) – (AR X AQ)
P	=	(50 × 40) – (45 × 50)
	=	2,000 – 2250 = 250 A
Q	=	(40 × 60) – (55 × 60)
	=	2400 – 3300 = 900 A
	=	1150 A
(2) Material Price Variance	=	AQ (SR – AR)
P	=	50(50 -45) = 250 F
Q	=	60(40 – 55) = 900 A
	=	650 A
(3) Material Usage Variance	=	SR(SQ – AQ)
P	=	50(40 – 50) = 500 A
Q	=	40(60 – 60) = 0
	=	500 A
(4) Material Mix Variance	=	SR (RSQ – AQ)
P	=	50(44 – 50) = 300 A
Q	=	40(66 – 60) = 240 F = 60 A
(5) Material Yield Variance	=	SR (SQ – RSQ)
P	=	50(40 – 44) = 200 A
Q	=	40 (60 – 66) = 240 A
	=	440 A

Illustration 15: Following data is given for 10 units of finished goods “A” 50 units at ₹ 2 per unit, “B” 80 units at ₹ 4 per unit and “Z” 70 units at ₹ 3 per units. During the particular accounting period 65 units of finished Goods are manufactured and actual data is:

A 350 units at ₹ 1.95;

B 500 units at ₹ 3.95;

C 450 units at ₹ 3.35;

Calculate Material Variances.

[TYB.Com. Modified]

Solution:

Material	Standard (65 units)		Actual (65 units)		RSQ
	SQ	SR	AQ	AR	
A	325	2	350	1.95	$\frac{325}{1300} \times 1300 = 325$
B	520	4	500	3.95	
C	455	3	450	3.35	
Total	1300	-	1300		$\frac{520}{1300} \times 1300 = 520$ $\frac{455}{1300} \times 1300 = 455$ 1300

$$\begin{aligned}
 (1) \text{ Material Cost Variance} &= (\text{SR} \times \text{SQ}) - (\text{AR} \times \text{AQ}) \\
 \text{A} &= (2 \times 325) - (1.95 \times 350) \\
 &= 650 - 682.5 = 32.5 \text{ A} \\
 \text{B} &= (4 \times 520) - (3.95 \times 500) \\
 &= 2080 - 1975 = 105 \text{ F} \\
 \text{C} &= (3 \times 455) - (3.35 \times 450) \\
 &= 1365 - 1507.5 = 142.5 \text{ A} \\
 &= 70 \text{ A} \\
 (2) \text{ Material Price Variance} &= \text{AQ}(\text{SR} - \text{AR}) \\
 \text{A} &= 350(2 - 1.95) = 17.5 \text{ F} \\
 \text{B} &= 500(4 - 3.95) = 25 \text{ F} \\
 \text{C} &= 450(3 - 3.35) = 157.5 \text{ A} \\
 &= 115 \text{ A} \\
 (3) \text{ Material usage Variance} &= \text{SR}(\text{SQ} - \text{AQ}) \\
 \text{A} &= 2(325 - 350) = 50 \text{ A} \\
 \text{B} &= 4(520 - 500) = 80 \text{ F} \\
 \text{C} &= 3(455 - 450) = 15 \text{ F} \\
 &= 45 \text{ F} \\
 (4) \text{ Material Mix variance} &= \text{SR}(\text{RSQ} - \text{AQ}) \\
 \text{A} &= 2(325 - 350) = 50 \text{ A} \\
 \text{B} &= 4(520 - 500) = 80 \text{ F} \\
 \text{C} &= 3(455 - 450) = 15 \text{ F} \\
 &= 45 \text{ F} \\
 (5) \text{ Material Yield Variance} &= \text{SR}(\text{SQ} - \text{RSQ}) \\
 \text{A} &= 2(325 - 325) = 0 \\
 \text{B} &= 4(520 - 520) = 0 \\
 \text{C} &= 3(455 - 455) = 0 \\
 &= \text{Zero}
 \end{aligned}$$

Illustration 16: Following information pertains to Salman Ltd.

Standard: 182 units				Actual: 182 units			
Materials	Units	Rate	Amt	Materials	Units	Rate	Amt
	SQ	SR	SC		AQ	AR	AC
A	121	10	1,210.0	A	140	9.5	1,330
B	81	8.5	688.5	B	60	9	540
	202		1,898.5		200		1,870
Less: Loss	20			Less: Loss	18		
	182				182		

Calculate all Material Variances.

[T.Y.BAF Modified]

Solution:

$$\begin{aligned}
 (1) \text{ Material Cost Variance} &= (\text{SR} \times \text{SQ}) - (\text{AR} \times \text{AQ}) \\
 &= 1,898.5 - 1870 \\
 &= 28.5 \text{ F} \\
 (2) \text{ Material Price Variance} &= \text{AQ}(\text{SR} - \text{AR}) \\
 \text{A} &= 140(10 - 9.5) = 70 \text{ F} \\
 \text{B} &= 60(8.5 - 9) = 30 \text{ A} \\
 &= 40\text{F} \\
 (3) \text{ Material Usage Variance} &= \text{SR}(\text{SQ} - \text{AQ}) \\
 \text{A} &= 10(121 - 140) = 190.0 \text{ A} \\
 \text{B} &= 8.5(81 - 60) = 178.5\text{F} \\
 &= 11.5 \text{ A} \\
 (4) \text{ Material Mix Variance} &= \text{SR}(\text{RSQ} - \text{AQ}) \\
 \text{A} &= 10(120 - 140) = 200 \text{ A} \\
 \text{B} &= 8.5(80 - 60) = 170 \text{ F} \\
 &= 30 \text{ A} \\
 (5) \text{ Material Yield Variance} &= \text{SR}(\text{SQ} - \text{RSQ}) \\
 \text{A} &= 10(121 - 120) = 10.0 \text{ F} \\
 \text{B} &= 8.5(81 - 80) = 8.5\text{F} \\
 &= 18.5 \text{ F}
 \end{aligned}$$

RSQ:

$$A = \frac{121}{202} \times 200 = 120$$

$$B = \frac{81}{202} \times 200 = 80$$

Illustration 17: Calculate Variable Overheads

- (1) Cost Variance
- (2) Expenditure Variance
- (3) Efficiency Variance

From the following information:

Particulars	Budget ₹	Actual ₹
Variable Overheads (₹)	10,000	8,910
Hours	10,000	9,900
Output	5,000	4,500

[CS Modified]

Solution:

$$(1) \text{ Variable Overhead Cost Variance} = (\text{Actual Output} \times \text{Variable Overhead rate p.u.})$$

– Actual Variable Overhead Cost

$$\left(4,500 \times \frac{10,000}{5,000} \right) - 8,910$$

$$(4,500 \times 2) - 8,910$$

$$9,000 - 8,910$$

$$= 90 \text{ F}$$

$$(2) \text{ Variable Overhead Expenditure Variance} = [(\text{AQ} \times \text{SR}) - \text{Actual Variable Cost}]$$

$$[(4,500 \times 2) - 8,910]$$

$$9,000 - 8,910$$

$$= 90 \text{ F}$$

$$(3) \text{ Variable Overheads Efficiency Variance} = \text{SR} (\text{Actual Production} - \text{Standard Production})$$

$$2(4,500 - 5,000)$$

$$2 \times 500$$

$$= 1,000 \text{ A}$$

Illustration 18: The Following data is given

Particulars	Budgeted	Actual
Production in units	400	360
Man-hours to produce above	8,000	7,000
Variable Overheads (₹)	10,000	9,150

The Standard time to produce one unit of the product is 20 hours.

Calculate:

- (1) Variable Overhead efficiency variance
- (2) Variable overhead expenditure variance
- (3) Variable overhead cost variance

[CS Modified]

Solution:**Workings:**

$$\begin{aligned}
 (a) \text{ Standard Hours (SH) for Actual Output} &= 20 \times 360 \\
 &= 7,200 \text{ hours} \\
 (b) \text{ Standard Rate (SR)} &= \frac{\text{Budgeted Overheads}}{\text{Budgeted Hours}} \\
 &= \frac{\text{₹ } 10,000}{8,000 \text{ hours}} \\
 &= \text{₹ } 1.25 \text{ per hour}
 \end{aligned}$$

$$\begin{aligned}
 \text{(c) Actual Rate (AR)} &= \frac{\text{Actual Overheads}}{\text{Actual hours}} \\
 &= \frac{\text{₹ 9,150}}{7,000 \text{ hours}} \\
 &= \text{₹ 1.307 per hour} \\
 \text{(1) Variable Overheads Variance (VOV)} &= (\text{SH X SR}) - (\text{AH X AR}) \\
 &= (7,200 \times 1.25) - 9,150 \\
 &= 9,000 - 9,150 \\
 &= 150 \text{ A} \\
 \text{(2) Variable Overheads Efficiency Variance (VEFV)} &= (\text{SH} - \text{AH}) \times \text{SR} \\
 &= (7,200 - 7,000) \times 1.25 \\
 &= 250 \text{ F} \\
 \text{(3) Variable Overheads Expenditure Variance (VEXV)} &= (\text{SR} - \text{AR}) \times \text{AH} \\
 &= (1.25 - 1.307) \times 7,000 \\
 &= 400 \text{ A}
 \end{aligned}$$

Illustration 19: The Fixed Production overhead of producing one unit of an item was ₹ 35. Fixed production overheads were absorbed on the expected annual output of 13,200 units.

The actual production of one month was 1,000 units

The Actual fixed overhead for that month were ₹ 39,000

Calculate:

- (1) Fixed Overhead Cost Variance
- (2) Fixed Overhead Volume Variance
- (3) Fixed Overhead Expenditure Variance

[CA Modified]

Solution:

$$\begin{aligned}
 \text{(1) Fixed Overhead Cost Variance} &= (\text{SH X SR}) - \text{Actual Overheads} \\
 &= (12,000 \times 35) - 4,68,000 \\
 &= 4,20,000 - 4,68,000 \\
 &= 48,000 \text{ A} \\
 \text{(2) Fixed Overhead Volume Variance} &= \text{Standard FO} - \text{Budgeted FO} \\
 &= 4,20,000 - (35 \times 13,200) \\
 &= 4,20,000 - 4,62,000 \\
 &= 42,000 \text{ A} \\
 \text{(3) Fixed Overhead Expenditure Variance} &= (\text{BQ X SR}) - \text{Actual FO} \\
 &= (13,200 \times 35) - (39,000 \times 12) \\
 &= 4,62,000 - 4,68,000 \\
 &= 6,000 \text{ A}
 \end{aligned}$$

Illustration 20: The Following information is available from the record of the factory:

Particulars	Budget	Actual
Fixed Overheads For June (₹)	10,000	12,000
Production in June (Units)	2,000	2,100
Standard Time per unit (Hours)	10	-
Actual hours Worked in June	-	22,000

Calculate:

- (1) Fixed Overheads Cost Variance
- (2) Fixed Overheads expenditure Variance
- (3) Fixed Overheads Volume Variance

[CMA Modified]

Solution:

- (1) Fixed Overhead Cost Variance = $[(AQ \times SR) - \text{Actual Fixed Overheads}]$

$$\left(\left[2,100 \times \frac{10,000}{2,000} \right] - 12,000 \right)$$

$$[(2,100 \times 5) - 12,000]$$

$$10,500 - 12,000$$

$$= 1,500 \text{ A}$$

- (2) Fixed Overhead Expenditure Variance = Budgeted Fixed Overheads – Actual Fixed O/h

$$10,000 - 12,000$$

$$= 2,000 \text{ A}$$

- (3) Fixed Overhead Volume Variance = $(AQ \times SR) - \text{Budgeted Fixed Overheads}$

$$= \left(2,100 \times \frac{10,000}{2,000} \right) - 10,000$$

$$= (2,100 \times 5) - 10,000$$

$$= 10,500 - 10,000$$

$$= 500 \text{ F}$$

Illustration 21: Shruti Ltd. has furnished the following information for the month of May, 2002

	Budget	Actual
Output (Units)	400	425
Hours	8,000	8,600
Fixed Overheads	₹ 40,000	₹ 47,300
Variable Overhead	₹ 64,000	₹ 73,100

Calculate the following Variances:

- (a) Fixed Overhead Variance
- (b) Fixed Overhead Volume Variance

- (c) Fixed Overhead Expenditure Variance
 (d) Variable Overhead Variance
 (e) Variable Overhead Expenditure Variance

[CMA & CS Modified]

Solution:

- (a) Fixed Overhead Variance = [Standard FO for Actual Output] – [Actual FO incurred]

$$= \left(\frac{40,000}{400} \times 425 \right) - 47,300$$

$$= 42,500 - 47,300$$

$$= 4,800 \text{ A}$$
- (b) Fixed Overhead Volume Variance = [Fixed Overhead recovery on Actual Output at standard rate] – [Budgeted Fixed Overhead Expenses]

$$= \left(\frac{40,000}{400} \times 425 \right) - 40,000$$

$$= 42,500 - 40,000$$

$$= 2,500 \text{ F}$$
- (c) Fixed Overhead Expenditure Variance = Budgeted FO – Actual FO

$$= 40,000 - 47,300$$

$$= 7,300 \text{ A}$$
- (d) Variable Overhead Variance = (Standard Variable CPU x Actual Output units) – Actual Variable Overhead Expenses

$$= \left(\frac{64,000}{400} \times 425 \right) - 73,100$$

$$= 68,000 - 73,100$$

$$= 5,100 \text{ A}$$
- (e) Variable Overhead Expenditure Variance = [Standard Variable overhead expense per hour x Actual Hours worked] – Actual Variable OH expenses incurred.

$$= \left(\frac{64,000}{8,000} \times 8,600 \right) - 73,100$$

$$= 68,800 - 73,100$$

$$= 4,300 \text{ A}$$

Illustration 22: ABC Ltd. has furnished the following information:

Particulars	Budget	Actual
Output (units)	15,000	16,000
No. of Working Days	25	28
Fixed Overheads (₹)	30,000	30,500
Variable Overheads (₹)	45,000	47,000

Calculate:

- (1) Fixed Overheads cost variance
- (2) Fixed Overhead expenditure Variance
- (3) Fixed Overhead Volume Variance
- (4) Variable Overhead Cost Variance
- (5) Total overhead cost variance

[CS Modified]

Solution:

- (1) Total Overhead Cost Variance = (Actual units x SR) – Actual Overhead Cost

$$\left(16,000 \times \frac{30,000 + 45,000}{15,000} \right) - 30,500 + 47,000$$

$$(16,000 \times 5) - 77,500$$

$$= 80,000 - 77,500$$

$$= 2,500 \text{ F}$$

- (2) Variable Overhead Cost Variance = [(AQ × SR) – Actual Variable Overheads]

$$\left(\left[16,000 \times \frac{45,000}{15,000} \right] - 47,000 \right)$$

$$[(16,000 \times 3) - 47,000]$$

$$48,000 - 47,000$$

$$= 1,000 \text{ F}$$

- (3) Fixed Overhead Cost Variance = [(AQ × SR) – Actual Fixed overheads]

$$\left(\left[16,000 \times \frac{30,000}{15,000} \right] - 30,500 \right)$$

$$[(16,000 \times 2) - 30,500]$$

$$= 32,000 - 30,500$$

$$= 1,500 \text{ F}$$

- (4) Fixed overhead Volume Variance = (AQ X SR) – Budgeted Fixed Overheads

$$(16,000 \times 2) - 30,000$$

$$= 32,000 - 30,000$$

$$= 2,000 \text{ F}$$

- (5) Fixed overhead Expenditure Variance = Budgeted Fixed Overheads – Actual Fixed O/h

$$30,000 - 30,500$$

$$= 500 \text{ A}$$

Illustration 23: Vivek Ltd. has furnished you the following for the month of August 2006:

	Budget	Actual
Output (Units)	30,000	32,500
Hours	30,000	33,000
Fixed Overhead (₹)	45,000	50,000
Variable Overhead (₹)	60,000	68,000
Working Days	25	26

[CA & CMA Modified]

Calculate the Variance

Solution:

(1) Variable Overhead Variance

$$\begin{aligned}
 &= \left(\frac{\text{Standard Variable Cost per unit}}{\text{Budget Output}} \times \text{Actual outputs units} \right) - \left(\frac{\text{Actual Variable Overhead Expenses}}{\text{Actual Output}} \right) \\
 &= \left(\frac{60,000}{30,000} \times 32,500 \right) - 68,000 \\
 &= 65,000 - 68,000 \\
 &= 3,000 \text{ A}
 \end{aligned}$$

(2) Variable Overhead Expenditure variance

$$\begin{aligned}
 &= \left(\frac{\text{Standard Variable Overhead Expenses Per hour}}{\text{Budget Hours}} \times \text{Actual Hours worked} \right) - \left(\frac{\text{Actual Variable Overhead expenses Incurred}}{\text{Actual Output}} \right) \\
 &= \left(\frac{60,000}{30,000} \times 33,000 \right) - 68,000 \\
 &= 66,000 - 68,000 \\
 &= 2,000 \text{ A}
 \end{aligned}$$

(3) Variable Overhead Efficiency Variance

$$\begin{aligned}
 &= \left(\frac{\text{Actual Output}}{\text{Actual Hours}} \times \text{Standard hour's per unit time} - \text{Actual Hours} \right) \times \text{Standard variable Overhead Expenses per hour} \\
 &= [(32,500 \times 1) - 33,000] \times 2 \\
 &= [32,500 - 33,000] \times 2 \\
 &= -500 \times 2 \\
 &= 1,000 \text{ A}
 \end{aligned}$$

(4) Fixed Overhead Cost Variance

$$= \left(\frac{\text{Standard fixed Overhead}}{\text{For Actual output}} \right) - \left(\frac{\text{Actual Fixed Overhead Incurred}}{\text{Actual Output}} \right)$$

$$= \left(\frac{45,000}{30,000} \times 32,500 \right) - 50,000$$

$$= 48,750 - 50,000$$

$$= 1,250 \text{ A}$$

- (5) Fixed overhead Expenditure Variance

$$= \text{Budgeted fixed overhead} - \text{Actual Fixed overhead}$$

$$= 45,000 - 50,000$$

$$= 5,000 \text{ A}$$

- (6) Fixed Overhead Expenditure Variance

$$= \left(\frac{\text{Fixed Overhead Expenses Recovered}}{\text{On Actual Output at Standard rate}} \right) - \left(\frac{\text{Budgeted Fixed}}{\text{Overhead Expenses}} \right)$$

$$= \left(\frac{45,000}{30,000} \times 32,500 \right) - 45,000$$

$$= 48,750 - 45,000$$

$$= 3,750 \text{ F}$$

- (7) Fixed Overhead Efficiency Variance

$$= \text{Standard Rate SH for Actual Output} - \text{AH}$$

$$= \frac{-45,000}{30,000} \left(\frac{30,000}{30,000} \times 32,500 \right) - 33,000$$

$$= 1.5 [32,500 - 33,000]$$

$$= 750 \text{ A}$$

- (8) Fixed Overhead with Calendar Variance

$$= \left(\frac{\text{Standard Fixed}}{\text{Overhead Recovery rate per unit}} \times \frac{\text{Standard Output for}}{\text{actual hours}} \times \frac{\text{Standard output for}}{\text{Actual Working Days}} \right)$$

$$= \frac{45,000}{30,000} \left(\frac{30,000}{30,000} \times 33,000 \right) - \left(\frac{30,000}{25} \times 26 \right)$$

$$= 1.5 (33,000 - 31,200)$$

$$= 2,700 \text{ F}$$

- (9) Fixed Overhead Calendar variance

$$= (\text{Standard Fixed Overhead recovery rate per day}) \times (\text{No. of Excess Days worked})$$

$$= \frac{45,000}{25} \times 26 - 25$$

$$= ₹ 1,800 \text{ F}$$

Illustration 24: Calculate the overhead variance from the following data:

	Budget	Actual
Number of Working days	20	22
Man hours per Day	8,000	8,400

Output per man hours in units	1.0	0.9
Fixed overhead cost (₹)	1,60,000	1,68,000

[CA Modified]

Solution

- (1) Fixed overhead cost Variance

$$= (\text{SR per hour} \times \text{Actual Output}) - \text{Actual Fixed overhead}$$

$$= \left(\left[\frac{1,60,000}{20 \times 8,000 \times 1} \right] \times [22 \times 8,400 \times 0.9] \right) - 1,68,000$$

$$= (1 \times 1,66,320) - 1,68,000$$

$$= 1,66,320 - 1,68,000$$

$$= 1,680 \text{ A}$$

- (2) Fixed overhead expenditure Variance

$$= \text{standard Recovery rate}$$

$$= (\text{Standard Recovery rate} \times \text{Budgeted output}) - \text{Actual Fixed Overhead}$$

$$= \left(1 \times \left[20 \times \frac{8,000}{1} \right] \right) - 1,68,000$$

$$= 1,60,000 - 1,68,000$$

$$= 8,000 \text{ A}$$

- (3) Fixed overhead Volume Variance

$$= \left(\frac{\text{Fixed overhead Expenses recovered}}{\text{On actual output at Standard rate}} \right) - \left(\frac{\text{Budgeted fixed}}{\text{overhead expenses}} \right)$$

$$= \left[\frac{1,60,000}{1 \times 20 \times 8000} \right] \times 1,66,320 - 1,60,000$$

$$= (1 \times 1,66,320) - 1,60,000$$

$$= 6,320 \text{ F}$$

- (4) Fixed overhead Efficiency variance

$$= \left(\frac{\text{Standard Fixed overhead}}{\text{Recovery rate per hour}} \right) - \left(\frac{\text{Standard Hours for}}{\text{Actual Report}} - \text{Actual Report} \right)$$

$$= \left[\frac{1,60,000}{1,60,000} \times (1,66,320 - 1,84,800) \right]$$

$$= 1 \times -18,480$$

$$= 18,480 \text{ A}$$

- (5) Fixed Overhead Capacity Variance

- (a) With Calendar Variance

$$= \left(\frac{\text{Standard Recovery}}{\text{Rate per hour}} \right) - \left(\frac{\text{Standard output}}{\text{Actual Hours}} - \frac{\text{Standard output for}}{\text{Actual working days}} \right)$$

$$= 1 \times [1 \times (22 \times 8,400) - (1 \times 8,000 \times 22)]$$

$$= 1 \times [1,84,800 - 1,76,000]$$

$$= 8,800 \text{ F}$$

(b) Fixed overhead calendar Variance

$$= \left(\frac{\text{Standard Fixed Overhead}}{\text{Recovery rate per day}} \right) - \left(\frac{\text{Number of excess}}{\text{days of work}} \right)$$

$$= \frac{1,60,000}{20} \times (22-20)$$

$$= 8,000 \times 2$$

$$= 16,000 \text{ F}$$

Exercise

1. S.V Ltd. manufactures a single product, the standard mix which is:

Material X 60 % at ₹ 20 per kg

Material Y 40% at ₹ 10 per kg

Normal Loss in production is 30% of input. Due to shortage of Material X the standard mix was changed.

Actual results for March 2006 were;

Material X 105 kg. At ₹ 20 per kg

Material Y 95 kg. At 9 per kg

Input 200 kg

Loss 35 kg

Output 165 kg

Calculate:

(a) Material Price Variance

(b) Material Usage Variance

(c) Material Mix Variance

(d) Material Yield Variance

[Ans.: (a) Material Price Variance: A Nil; B 95 F; Total 95 F

(b) Material Usage Variance: A 300 F; B150 A; Total 150 F

(c) Material Mix Variance: A 300 F; B 150 A; Total 150 F

(d) Material Yield Variance: Total 100 F]

2. The Standard Cost of certain chemical mixture is:

35%Material X at ₹ 25 per kg

65% Material Y at ₹ 36 per kg

A Standard loss at 5% is expected in production.

During a period there is used:

125 Kg of material X at ₹ 27 per kg

275 Kg of material Y at ₹ 34 per kg

The actual output was 365 kg.

Calculate:

- (a) Material Cost Variance
- (b) Material Price Variance
- (c) Material Mix Variance
- (d) Material Yield Variance

- [Ans.: (a) Material Cost Variance: 373 A
 (b) Material Price Variance: X 250 A; Y 550 F; Total 300 F
 (c) Material Mix Variance: X 375 F; Y 540 A; Total 165 A
 (d) Material Yield Variance: 508 A]

3. From the following data prepare a unit cost statement showing the prime cost of products A and B together with analysis of variances:

	Product A	Product B
Material: Standard	600 kg @ ₹ 5.00	90 Kg ₹ 3.00
Actual	580 Kg @ ₹ 5.50	100 Kg @ ₹ 2.80
Labour: Standard	80 Hrs. @ ₹ 2.00	16 Hrs. @ ₹ 2.80
Actual	92 Hrs. @ ₹ 1.75	14 Hrs. @ ₹ 2.00

- [Ans.: 1. Standard Prime Cost: A 3,160; B 314.80
 2. Actual Prime Cost: A 3,351; B 316.40
 3. Prime Cost Variance: A 191 A; b 20 F
 4. Material Price Variance: A 290 F; B 20 A
 5. Material Usage Variance: A 100 F; B 30 A
 6. Material Cost Variance: A 190 A; B 10 A
 7. Labour rate Variance: A 23 F; B 2.8 F
 8. Labour Efficiency Variance: A 24 A; B 5.6 F
 9. Labour Cost Variance: A 24 A; B 8.4 F]
4. The following information is gathered from the labour records of SRK Co.
1. Payroll allocations for direct labour ₹ 20,000
 2. Time card analysis shows that 8,000 hours were worked on production lines.
 3. Production reports for the period shows that 4,000 units have been completed each having standard labour time of 1 1/2 hours and standard labour rate ₹ 2 per hour.

Calculate:

- (a) Labour Rate Variance
 - (b) Labour Efficiency Variance
 - (c) Labour Cost Variance
5. The Standard material cost for 200 units of output is:

Materials	Kg	Rate per Kg
A	50	12
B	100	9
C	100	10

The Actual cost for 8,000 units is as follows:

Materials	Kg	Total Cost
A	2100	28,350
B	3750	30,750
C	4150	46,480

Calculate Material Cost Variance, Material Price Variance and Material Usage Variance.

6. The standard output of production 'EXE' is 25 units per hour in manufacturing department of a company employing 100 workers. The hourly wage rate per labour hour is ₹ 6.

In a 42- hour week, the department produced 1,040 units 'EXE' despite 5% of the time paid were lost due to an abnormal reason. The hourly wage rate actually paid were ₹ 6.60, ₹ 6 and 5.70 respectively to 10, 30 and 60 of the workers.

Compute Relevant Variances.

- [Ans.: 1. Labour Cost Variance 432 F
 2. Labour Rate Variance
 84 A; Nil; 756 F; Total 672 F
 3. Labour Efficiency Variance 1,020 F
 4. Labour Idle Time Variance 1,260 A]

7. The following information was obtained from the records of a manufacturing unit using standard costing system:

	Standard	Actual
Production	4,00 units	3,800 units
Working Days	20	21
Fixed Overhead (₹)	40,000	39,000
Variable Overhead (₹)	12,000	12,000

You are required to calculate the following overhead variances:

- (a) Variable Overhead Variance.
 (b) Fixed Overhead Variance.
 1. Expenditure Variance
 2. Volume Variance
 3. Efficiency Variance
 4. Calendar Variance
 (c) Also prepare a reconciliation statement for the standard fixed expenses worked out at standard fixed overhead rate and the actual fixed overhead.

- [Ans.: 1. Variable Overhead Cost Variance 600 A
 2. Fixed Overhead Variance 1,000 A
 3. Fixed Overhead Expenditure Variance 1,000 A
 4. Fixed Overhead Volume Variance 2,000 A
 5. Fixed Overhead Efficiency Variance 4,000 A
 6. Fixed Overhead Calendar Variance 2,000 F]

8. From the following information about sales, calculate:

- Total Sales Variance
- Sales Price Variance
- Sales Volume Variance
- Sales Mix Variance
- Sales Quantity Variance.

Product	Product No.	Standard rate in ₹ per unit	₹	Product nos.	Actual rate in ₹ per unit	₹
A	5,000	5	25,000	6,000	6	36,000
B	4,000	6	24,000	5,000	5	25,000
C	3,000	7	21,000	4,000	8	32,000
	12,000		70,000	15,000		93,000

- [Ans.: 1. Total Sales Variance 23,000 F
 2. Sales Price Variance: A 6,000 F; B 5,000 A; C 4,000 F; Total 5,000F
 3. Sales Volume Variance: A 5,000 F; B 6,000 F; C 7,000 F; Total 18,000 F
 4. Sales Mix Variance 500 F
 5. Sales Quantity Variance 17,500 F]

9. From the following information of Kautsa Corporation, compute:

- Price Variance
- Usage Variance and
- Mix Variances

	Quantity Kgs.	Unit Price	Total	Quantity Kgs.	Unit Price	Total
Material A	20	4	80	10	6	60
Material B	40	6	240	20	12	240
Material C	40	12	480	30	10	300
	100		800	60		600

- [Ans.: 80 (A)
 280 (F)
 40 (A)]

10. The Standard material cost for a normal mix of one ton of a chemical X is based on the following:

Chemical	Usage in Kg.	Price Per kg. (₹)
A	240	6
B	400	12
C	640	10

During a month 6.25 tons of Chemical X were produced from the following:

Chemicals	Usage in tons	Cost (₹)
A	1.6	11,200
B	2.4	30,000
C	4.5	47,250

Analyse all Variances.

11. The Standard cost of a certain chemical mixture is:
 40% material X at ₹ 200 per ton
 60% material Y at ₹ 300 per ton
 A Standard loss of 103 is expected in production.
 During a period there is used
 90% tons of Material X at the cost of ₹ 180 per ton
 110 tons Material Y at the cost of ₹ 340 per ton.
 The weight produced is 182 tons of good production.
 Calculate and present:
- Material Price Variance
 - Material Usage Variance
 - Material Mix Variance
 - Material Yield Variance.
12. The Devansh Badani Co. Ltd. manufactures a single product, the standard mix Material A 60% @ ₹ 20 per kg., material B 40% @ ₹ 10 per kg. Normal loss in production is 20% of input. Due to shortage of material A the standard mix was changed.
 Actuals are:
- | | | |
|------------|---------------|-------|
| Material A | 210 Kg @ ₹ 20 | 4,200 |
| Material B | 190 kg @ ₹ 9 | 1,710 |
| Input | 400 Kg | 5,910 |
| Loss | 60 Kg | - |
| Output | 340 Kg | 5,910 |
- Calculate material price, mixture yields and usage variances.
13. From the following data, calculate:
- Material Cost Variance
 - Material Price Variance
 - Material Usage Variance

Name of Material	Standard		Actual	
	Kg.	Rate (₹)	Kg.	Rate (₹)
X	8,000	1.05	7500	1.25
Y	3,000	2.15	3300	2.30
Z	2,000	3.30	2400	3.50

[Ans.: 3,915 (A)
2,475 (F)
1,440 (A)]

14. Using the following information for Department X,
Calculate all possible labour variances.
- | | |
|--------------------------------|-------|
| Actual Wages rate per hour (₹) | 3.5 |
| Standard hours for production | 8,640 |
| Standard rate per Hour (₹) | 3 |
| Actual hours worked | 8,200 |
15. From the following particulars in respect of a product 'X' in which raw materials 'A' and 'B' are used. Calculate:
1. Material Cost Variance
 2. Material Price Variance
 3. Material Mix Variance
 4. Material Yield Variance

Materials (Input)	Standard		Actual	
	Tons	Rate (₹)	Tons	Rate (₹)
A	120	10.00	140	9.50
B	80	7.50	60	9.00
	200		200	
Loss	20		18	

Objective Questions

I. Fill in the Blanks

1. The difference between total actual cost incurred and total standard cost applied is referred to as _____.
2. The difference between what was paid for inputs and what should have been paid for inputs is referred to as a _____.
3. The difference between standard quantity allowed and quantity used for a unit of output is known as an _____.
4. The difference between actual variable overhead and budgeted variable overhead based upon actual hours is referred to as the _____.
5. The difference between actual and budgeted fixed factory overhead is referred to as a _____.
6. When multiple materials are used, the effect of substituting a non-standard mix of materials during the production process is referred to as a _____ variance.
7. When multiple labour categories are used, the financial effect of using a different mix of workers in a production process is referred to as a _____ variance.

[Ans.: 1. Total Variance, 2. Price Variance, 3. Efficiency Variance, 4. Variable Overhead Spending Variance, 5. Fixed Overhead Spending Variance, 6. Material Mix, 7. Labour Mix

II. True or False

1. Specifications for materials are compiled on a bill of materials.
2. An operations flow document shows all processes necessary to manufacture one unit of a product.
3. A standard cost card is prepared before developing manufacturing standards for direct materials, direct labour, and factory overhead.
4. The total variance can provide useful information about the source of cost differences.
5. The formula for price/rate variance is $(AP - SP) \times SQ$
6. The price variance reflects the difference between the quantity of inputs used and the standard quantity allowed for the output of a period.
7. The usage variance reflects the difference between the price paid for inputs and the standard price for those inputs.
8. The formula for usage variance is $(AQ - SQ) \times SP$
9. The point of purchase model calculates the materials price variance using the quantity of materials purchased.
10. The difference between the actual wages paid to employees and the standard wages for all hours worked is the labor rate variance.
11. The difference between the standard hours worked for a specific level of production and the actual hours worked is the labor rate variance.
12. A flexible budget is an effective tool for budgeting factory overhead.

[Ans.: 1. True, 2. True, 3. False, 4. False, 5. False, 6. False, 7. False, 8. True, 9. True, 10. True, 11. False, 12. True]

III. Multiple Choice. Write the Letter Only for your Best Answer.

1. A primary purpose of using a standard cost system is
 - (a) to make things easier for managers in the production facility.
 - (b) to provide a distinct measure of cost control.
 - (c) to minimize the cost per unit of production.
 - (d) b and c are correct.
2. The standard cost card contains quantities and costs for
 - (a) direct material only
 - (b) direct labor only.
 - (c) direct material and direct labor only
 - (d) direct material, direct labor, and overhead.
3. Which of the following statements regarding standard cost systems is **true**?
 - (a) Favorable variances are not necessarily good variances.
 - (b) Managers will investigate all variances from standard
 - (c) The production supervisor is generally responsible for material price variances.
 - (d) Standard costs cannot be used for planning purposes since costs normally change in the future.

4. In a standard cost system, Work in Process Inventory is ordinarily debited with
 - (a) actual costs of material and labor and a predetermined overhead cost for overhead
 - (b) standard costs based on the level of input activity (such as direct labor hours worked).
 - (c) standard costs based on production output.
 - (d) actual costs of material, labor, and overhead.
5. A standard cost system may be used in
 - (a) job order costing, but not process costing
 - (b) process costing, but not job order costing.
 - (c) either job order costing or process costing.
 - (d) neither job order costing nor process costing.
6. Standard costs may be used for
 - (a) product costing.
 - (b) planning.
 - (c) controlling.
 - (d) all of the above.
7. A purpose of standard costing is to
 - (a) replace budgets and budgeting
 - (b) simplify costing procedures.
 - (c) eliminate the need for actual costing for external reporting purposes.
 - (d) eliminate the need to account for year-end under-applied or over-applied manufacturing overhead.
8. Standard costs
 - (a) are estimates of costs attainable only under the most ideal conditions.
 - (b) are difficult to use with a process costing system
 - (c) can, if properly used, help motivate employees.
 - (d) require that significant unfavourable variances be investigated, but do not require that significant favorable variances be investigated.
9. A bill of material does **not** include
 - (a) quantity of component inputs.
 - (b) price of component inputs
 - (c) quality of component inputs.
 - (d) type of product output.
10. An operations flow document
 - (a) tracks the cost and quantity of material through an operation.
 - (b) tracks the network of control points from receipt of a customer's order through the delivery of the finished product.
 - (c) specifies tasks to make a unit and the times allowed for each task.
 - (d) charts the shortest path by which to arrange machines for completing products.

11. A total variance is best defined as the difference between total
- (a) actual cost and total cost applied for the standard output of the period.
 - (b) standard cost and total cost applied to production.
 - (c) actual cost and total standard cost of the actual input of the period.
 - (d) actual cost and total cost applied for the actual output of the period.

[Ans.: 1. (b), 2. (d), 3. (a), 4. (c), 5. (c), 6. (d), 7. (b), 8. (c), 9. (b), 10. (c), 11. (d)]



UNIVERSITY PROBLEMS AND SOLUTIONS

Q.1. Following relevant data of a firm is given

Particulars	Activity Levels (tons)			
	50,000 tons	60,000 tons	70,000 tons	80,000 tons
Variable Cost (₹ in thousands)	5,000	6,000	7,000	8,000
Semi-variable cost (₹ in thousands)	1,500	1,600	1,650	1,700
Fixed cost (₹ in thousands)	2,500	2,500	2,500	3,000
Total Cost (₹ in thousands)	9,000	10,100	10,100	12,700

The fixed costs follow step-grap pattern as is clear from the above and the semi-variable costs change at uniform rate between the above given activity levels. Given that the firm operates at 55,000 tons level at present.

- (A) Calculate the additional/incremental costs if it manufactures additional (a) 10,000 tons (b) 15,000 tons and
- (B) Advise whether the firm should accept 'any one' of the following additional (special) export market offers and if Yes, 'which one' should it accept:
- (i) for 10,000 tons at a selling price of ₹ 125/- per ton.
- (ii) for 15,000 tons at a selling price of ₹ 150/- per ton.

Solution:

Pressure level = 55,000 tons

(I) Calculation of Additional / Incremental Cost

Particulars	10,000 tons (₹ in '000)	15,000 tons (₹ in '000)
Variable Cost	1,000	1,500
Semi-variable cost	75*	100
Fixed cost	–	500
Additional/Incremental cost (A)	1,075	2,100
2. Incremental Revenue:	(₹ in 000)	(₹ in 000)
(B) (i)	1,250	2,250 (ii)
Incremental profit (B– A)	175	150

Advice: Since the firm is getting an incremental profit of ₹ 175 (000) and ₹ 150 (000) in additional activity of 10,000 tons and 15,000 tons respectively. Hence, lower level offer should be accepted.

Q.2. A manufacturing company uses the following standard mix of their compound in one batch of 100 kgs. of its production time:

50 kgs of material X at the standard price of ₹ 2.

30 kgs of material Y at the standard price of ₹ 3.
 20 kgs of material Z at the standard price of ₹ 4.
 The Actual mix for a batch of 120 kgs was as follows:
 60 kgs of material X at the price of ₹ 3.
 40 kgs of material Y at the price of ₹ 2.5.
 10 kgs of material Z at the price of ₹ 3.
 Calculate the different materials variances.

Solution:

Manufacturing Co.

Products	Standard			Actual		
	Kg.	Rate	Amount	Kg.	Rate	Amount
X	50	2	100	60	3	180
Y	30	3	90	40	2.5	100
Z	20	4	80	10	3	30
	100		270	110		310
Loss	–		–	10		–
	100		270	120		310

$$\begin{aligned}
 (1) \text{ Material Cost Variance} &= \text{Std. Coat} - \text{Actual Cost} \\
 &= 270 - 310 \\
 &= 40 \text{ (A)}
 \end{aligned}$$

$$\begin{aligned}
 (2) \text{ Material Price Variance (MPV)} \\
 &= \text{Actual Quantity (SP} - \text{AP)} \\
 \text{X: } &60 (2-3) = 60 \text{ (A)} \\
 \text{Y: } &40 (3-2.5) = 20 \text{ (F)} \\
 \text{Z: } &10 (4-3) = 10 \text{ (F)} \\
 &\underline{30 \text{ (A)}}
 \end{aligned}$$

$$\begin{aligned}
 (3) \text{ Material Usage Variance:} \\
 &\text{SP (SQ} - \text{AQ)} \\
 \text{X: } &2 (50 - 60) = 20 \text{ (A)} \\
 \text{Y: } &3 (30 - 40) = 30 \text{ (A)} \\
 \text{Z: } &4 (20 - 10) = 40 \text{ (F)} \\
 &\underline{10 \text{ (A)}}
 \end{aligned}$$

$$\begin{aligned}
 \text{MCV} &= \text{MPV} + \text{MUV} \\
 &= 30 \text{ (A)} + 10 \text{ (A)} \\
 &= 40 \text{ (A)}
 \end{aligned}$$

$$\begin{aligned}
 \text{Revised Standard Quantity} \\
 \text{X} &= \frac{50}{100} \times 110 = 55 \\
 \text{Y} &= \frac{30}{100} \times 110 = 33
 \end{aligned}$$

$$Z = \frac{20}{100} \times 110 = 22$$

(4) Material Mix Variance

$$= (\text{Revised Quantity} - \text{Actual Quantity}) \times \text{SP}$$

$$X = (55 - 60) \times 2 = 10 \text{ (A)}$$

$$Y = (33 - 40) \times 3 = 21 \text{ (A)}$$

$$Z = (22 - 10) \times 4 = 32 \text{ (F)}$$

1 (F)

(5) Material yield Variance

$$= (\text{Revised Quantity} - \text{Std. Quantity}) \times \text{SP}$$

$$X = (55 - 50) \times 2 = 10 \text{ (F)}$$

$$Y = (33 - 30) \times 3 = 9 \text{ (F)}$$

$$Z = (22 - 20) \times 4 = 8 \text{ (F)}$$

27 (F)

Final Recalculation:

$$\begin{aligned} \text{MCV} &= \text{MPV} + \text{MMV} + \text{MYV} \\ &= 30 \text{ (A)} + 1 \text{ (F)} + 27 \text{ (F)} \\ \text{MCV} &= 2 \text{ (A)} \end{aligned}$$

Q.3. The following information relates to the productive activities of Delta Ltd. for 3 months ending on 31st March 2008:

Particulars	₹
Variables Expenses: (at 50% capacity)	
— Materials	6,00,000
— Labour	6,40,000
— Salesmen's Commission	<u>95,000</u>
	13,35,000
Semi-variable Expenses : (at 50% capacity)	
— Plant maintance	62,500
— Indirect Labour	2,47,500
— Salesmen's salaries	72,500
— Sundry	<u>65,000</u>
	4,47,500
Fixed Expenses:	
— Managements salaries	2,10,000
— Rent and taxes	1,40,000
— Depreciation of Machinery	1,75,000
— Sundry office Expenses	<u>2,22,500</u>
	<u>7,47,500</u>

It is further noted that semi-variable expenses remain constant between 40% and 70% capacity, increase by 10% of the above figures between 70% and 85% capacity and increased by 15% of the above figures between 85% and 100% capacity.

Fixed expenses remain constant whatever the level of activity may be. Sales at 60% capacity are ₹ 25,50,000, at 80% capacity are ₹ 34,00,000 and at 100% capacity are ₹ 42,50,000.

Assuming that all items produced are sold, you are required to prepare a flexible budget at 60%, 80% and 100% capacity.

Solution:

**In the Books of Delta Ltd.
Flexible Budget for 3 months ending 31.03.2008**

Capacity	60%	80%	100%
A. Fixed Expenses:			
Management Salaries	2,10,000	2,10,000	2,10,000
Rent and Taxes	1,40,000	1,40,000	1,40,000
Depreciation on Machinery	1,75,000	1,75,000	1,75,000
Sundry office Exp.	2,22,500	2,22,500	2,22,500
Total (A)	7,47,500	7,47,500	7,47,500
B. Semi-variable Expenses:			
Plant Maintenance	62,500	68,750	71,875
Indirect Labour	2,47,500	2,72,250	2,84,625
Salesmen Salaries	72,500	79,750	83,375
Sundry	65,000	71,500	74,750
Total (B)	4,47,500	4,92,250	5,14,625
C. Variable Expenses:			
Materials	7,20,000	9,60,000	12,00,000
Labour	7,68,000	10,24,000	12,80,000
Salesman Commission	1,14,000	1,52,000	1,90,000
Total (C)	16,02,000	21,36,000	26,70,000
D. Total Exp. (A+B+C)	27,97,000	33,75,750	39,32,125
E. Sales	25,50,000	34,00,000	42,50,000
F. Profit/Loss	(2,47,000)	24,250	3,17,875

Q.4. (b) You are given the following information for the next year:

Particulars	₹
Sales (10,000 units)	1,20,000
Variables Cost (10,000 units)	48,000
Fixed Cost	60,000

1. Find out the P.V. ratio and Break-even point.
2. Evaluate the effect of following on P.V. ratio and Break-even point.
 - (a) 10% decrease in variable cost
 - (b) 10% decrease in Fixed cost
 - (c) 10% increase in physical sales volume
 - (d) 5% increase in selling price.

Solution:

Calculation of PV ratio and BEP

Contribution = Sales – Variable Cost

$$72,000 = 1,20,000 - 48,000$$

Case	PV Ratio	B.E.P.
		$\frac{FC}{P/V \text{ Ratio}}$
(1)	Existing $\frac{72,000}{1,20,000} \times 100 = 60\%$	$\frac{60,000}{60\%} = 1,00,000$
(2)	(a) 10% decrease in variable cost contribution = $1,20,000 - [48,000 - 10\%]$ = 76,800 $\frac{76,800}{1,20,000} \times 100 = 64\%$	$\frac{60,000}{64\%}$ = 93,750
	(b) 10% decrease in $\frac{\text{Fixed Cost}}{\text{No change}} = 60\%$	FC = $60,000 - 6,000$ = 54,000 $\frac{54,000}{60\%} = 90,000$
	(c) 10% increase in sale volume New sale = $1,20,000 \times 10\%$ of 1,20,000 = 1,32,000 C = $1,32,000 - 48,000 = 84,000$ $\frac{84,000}{1,32,000} \times 100 = 63.63\%$	$\frac{60,000}{63.63\%}$ = 94,295
	(d) 5% increase in selling price SP/unit = $\frac{1,20,000}{10,000} = 12$ 5% increase $\frac{0.60}{12}$ Revised S. P. $\frac{12.60}{12}$ Contribution = $12.60 - 4.80$ = 7.80 $\frac{7.80}{12.60} \times 100 = 61.90\%$	$\frac{60,000}{61.90\%}$ = 96,930

Q.5. Write short notes on (any four):-

- Inter-link of Budgetary control and variance analysis;
- Utility of Standard Costing;
- Different types of budgets useful for a typical business enterprise;
- Implications of the angle of incidence;
- Special features of Operating costing;
- Importance of marginal costing in decision making function.

Solution:**(a) Inter-link of Budgetary Control and Variance Analysis**

The word 'budget' is derived from the french term "Budget" which denotes a leather pouch in which funds are appropriated for meeting anticipated expenses. A budget is quantitative expression of plan of action. It is a plan of the target to be achieved within a specified period. It is final and approved forecast. When the forecasts are approved by the management as a tentative plan for the future they become budget.

Budgetary Control is a mean of control in which the actual state of affairs is compared with that planned for so that appropriate action may be taken of with regard to any deviations before it is too late.

According to the Institute of Cost & Management Accountants, England "Budgetary Control is the establishment of budget relating to the responsibilities of the executives to the requirements of a policy and the continuous comparison of actual with the budgeted results either to secured by individual action, the objective of the policy or to provide the basis for its revision."

Thus Budgetary Control Involves: (a) Establishment of budget, (b) Continuous Comparisons of the actual with the budgeted performance to fix responsibility of persons for failure to achieve the targets, and (c) Revision of the budgets in the light of changed circumstances.

There are two steps in the process of budgetary control — Preparation of budget and implementation of the budget programme. Each sectional manager prepare budget for his section and submit the same to the sectional managers who prepares a consolidated budget for the department. The different budgets from different departments are consolidated and into the master budget by a budget committee under the chairmanship of an executive powerful enough to ensure prompt action and co-operation.

Preliminaries Required for Adoption of a System of Budgetary Control:

- 1. Budget Centres:** Budget Centre is a section of an organisation of a undertaking for the purpose of budgetary control. Budget centres or departments should be established for each of which budget will be set with the help of the head of the department concerned.
- 2. Accounting Records:** A prerequisite to the establishment of budgetary control system is that accounting system should be able to record and analyse accounting information.
- 3. Organisation Chart:** Organisation Chart defines the functions and responsibilities of each members of the management and ensure that each one knows his position in the organisation and his relationship to other members.
- 4. Budget Committee:** A budget Committee Consists of several members of the top management group. This committee will set the general guideline that the organisation is to follow and co-ordinate the separate budgets prepared by various organisational units.
- 5. Budget Manual:** Budget manual is a document which sets out the responsibilities of the persons engaged in the organisation. It is usually in printed form and form index is provided so that information can be quickly located.
- 6. Fixation of Budget Period:** Budget period is the period for which the budget is prepared and employed. There is no right period for every budget. It may vary

between short term and long term. Long term budgeting may be considerably affected by the unforeseen conditions.

7. **Key Factors:** Key factor is the factor the extent of whose influence must be assessed in order to ensure that functional budgets are reasonably capable of fulfilment Key factor is also known as "limiting" or "governing" or "principal budget" factors. Sale is the most often the key factor in an industry.

Variance Analysis: There is no uniformity of opinion as to the proper disposition of variances. Some cost accountants argue that variances of all types should be transferred to Costing Profit and Loss A/c. A second group of cost accountants are of opinion that the variances at the end of the year should be properly distributed over closing stock and cost of sales, so that both these times are shown at actual cost in financial statements. Although these two methods are easy to apply and may be used for practical purposes, the variances are not disposed of in accordance with the best accounting practice. According to the strict principles of cost accounting each variance should be carefully analysed so that causes of the same be ascertained. Then each variance should be disposed of in accordance with the underlying reasons for its existence. All variances which are the result of controllable operation should be transferred to Costing Profit and Loss A/c. On the other hand, these variances which are the result of uncontrollable conditions like changes in material prices, wage rate changes, etc. should be apportioned to inventories and cost of goods sold on some equitable basis.

(b) Utility of Standard Costing

Standard costing is defined as the preparation and use of standard costs, their, comparison with actual costs and the measurement and analysis of variances to their causes and points of incidence. Standard cost a predetermined cost is calculated from the management's standard of efficient operation and the relevant necessary expenditure. Standard costing play an important role in cost control and cost reduction.

1. **As a Measuring Yardstick of Performance:** Standard costing system establishes yardsticks against which the efficiency or inefficiency of actual performance are measured. Standard may be set in respect of the prices and quantity of materials, labour time and wage rates, production etc. These standards are used to measure the performance e.g. standards quantity of material specified for a particular job can be taken as a basis (standard) to control the actual usage of material. By calculating variance analysis the management can study the reason for deviation.
2. **As a Basis of Inventory Valuation:** Under standard costing valuation of inventory become simple. The valuation of inventory is made at standard costs and any difference between the actual costs and standards may be transferred to variance account. Thus, standard costing enables to maintain uniform pricing of raw material, work in progress and finished goods.
3. **As an Aid in Preparing Earning Budget:** Estimation of standard cost for each and every element of cost helps the management in estimating the earning too. Under the system of standard costing the output is valued at costs and the estimated earnings are also based on standard selling price of output is valued at costs and the estimated earnings to be realised during a given period can be calculated on the basis of difference between the standard costs and standard selling price. This is useful in preparation of earning subject.

4. As a Guide in Fixing Selling Price: Standard costing is very useful to the management in formulation of pricing policy for the products. The normal procedure is to add a certain margin of profit to the standard costs of the product. However, depending upon the marketing conditions this margin may vary from time to time. Normally the market price is influenced by the forces of demand and supply. Pricing policies may be formulated in advance before production starts. This helps in prompt decision making.

(c) Different Types of Budgets Useful for a Typical Business Enterprise

A functional budget is one which relates to any of the function or activities of an organisation. The function determine the scope of activities of various departments. Each department has to prepare its own budget. Functional budget is "a Budget of income or expenditure appropriate to, or the responsibility of a particular function (CIMA). All the functional budgets are summarised into what is known as "master budget. These functional budgets are thus subsidiary budgets of the "master budget".

There are several types of functional budgets depending upon the structure of organisation and need of control in each case. However, generally the following types of budgets are prepared:

- (i) Sales Budget:** This budget is prepared by sales manager. Preparation of sales budget is the most difficult job since it is very difficult to estimate future demands of a product. This is probably the most important budget as all other budgets depend on the sales budget.
- (ii) Production Budget:** The budget is prepared by production manager. It shows the quantity of products to be manufactured.
- (iii) Production Cost Budget:** This budget is also known as manufacturing budget. It is the quantity of goods to be manufactured expressed in terms of cost.
This budget consists of three subsidiary budgets:
 - (a) Materials budget
 - (b) Labour cost budget
 - (c) Manufacturing overhead budgets.
- (iv) Purchase Budget:** This budget lays down the quantity of materials to be purchased from month to month to ensure smooth production.
- (v) Cash Budget:** This represents the cash receipt and cash payments and estimated cash balance for each month of the period for which budget is prepared. Cash budget is a device for controlling and coordinating the financial side of a business.
- (vi) Capital Expenditure Budget:** It shows the planned outlay on fixed assets to be acquired during the budget period. Every care must be taken before preparing this budget.
- (vii) Selling and Distribution Cost Budget:** This budget is a forecast of selling and distribution expenses for the company's products during the budget period. This budget is closely connected with sales budget as selling and distribution expenses will be in proportion to sales.
- (viii) Research and Development Cost Budget:** Research cost means the cost of searching for a new or improved products, new applications of materials, or new or improved method.

Development cost is the cost of the process which begins with the implementation of the decision to produce a new or improved product or to employ a new or improved method.

(d) Implications of the Angle of Incidence

It is formed by the intersection of sales line and total cost line at the Break Even Point. It shows the rate at which the organisation is earning profit once the BEP is reached. This angle provides useful information about the rate at which profits are being made. The larger the angle the higher the rate of profit and vice-versa. The angle of incidence can be studied in conjunction with margin of safety. A large angle of incidence together with a high margin of safety indicates an extremely favourable situation. This can be shown by plotting a Break-Even Chart.

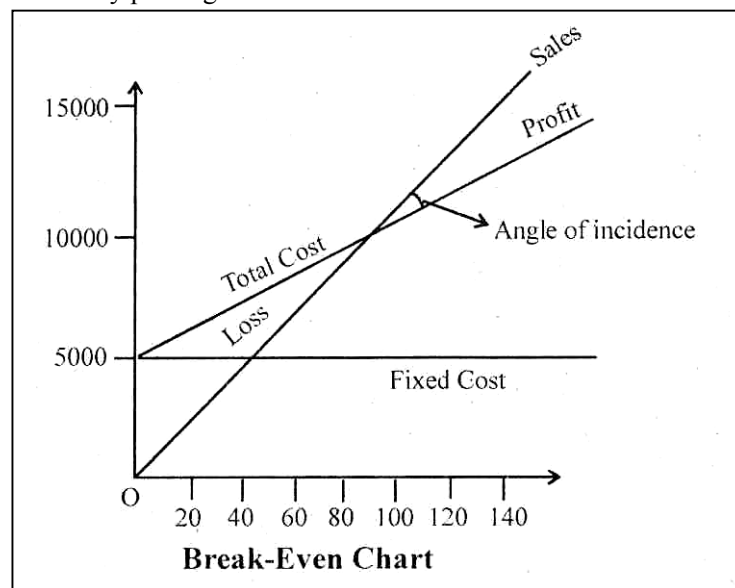

(f) Importance of Marginal Costing in Decision Making Function

In marginal costing, it is presumed that variable costs are related to output and Fixed costs are related to the period. Fixed costs are charged off to the P&L A/c.

Marginal costing necessitates the analysis of costs into fixed and variable. These types of costs behave differently with changes in the volume of output. The variable cost varies directly in proportion to change in the volume of output, which means that variable cost per unit remains constant regardless of the levels of output. Fixed costs, on the other hand, remain fixed at the same level regardless of changes in the volume of output, and vary per unit inversely with the change in total with time rather than with the level of output. For this reason fixed costs are also known as time or period costs because they accrue with the passage of time irrespective of the volume of output. Fixed cost is also called by other names like standby cost, constant cost, capacity cost, etc. Variable costs are also known as product costs as these are related to volume of output. Variable cost is also termed as direct cost, marginal cost, activity cost, volume cost, or out-of-pocket cost. Semi-variable cost is one which is partly fixed and partly variable. The fixed part of this cost is segregated and merged into the variable cost.

Marginal costing is basically concerned with the determination of product cost which consists of the total costs less the fixed costs i.e. direct materials, direct labour, direct

expenses and variable overhead. Thus, marginal cost is the variable cost (which forms part of product cost) and does not include fixed cost. Fixed costs are not included in the cost of production because the former bear relation to certain period of time and also vary per unit of production.

The technique of marginal costing is a valuable aid to management for decision making in many key areas such as the following:

- (a) The price at which a product should be sold.
- (b) Determination of volume of output.
- (c) Utilisation of surplus capacity.
- (d) Submission of tenders and quotations.
- (e) Acceptance of special order e.g. export order.
- (f) Make or buy a component.
- (g) Economic feasibility of major (capital) projects.
- (h) Replacement of a machinery.
- (i) Determining optimum product or sales mix.
- (u) Operate the plant or shut it down, etc.
- (k) Suspension or permanent closing down of a business.

Q.6. The following particulars are taken from the records of the company engaged in manufacturing two products, A and B, from a certain material:

Particulars	Product A (per unit)	Product B (per unit)
Sales	2,500	5,000
Material cost (₹ 50 per kg)	500	1,250
Direct labour (30 per hour)	750	1,500
Variable overheads	250	500

Total fixed overheads: ₹ 10,00,000

- (a) Comment on the profitability of each product when:
 - (i) Total sales in value is limited.
 - (ii) Raw materials is in short supply.
 - (iii) Production capacity (labour) is the limiting factor.
- (b) When total availability of raw materials is 20,000 kg and maximum sales potential of each product is 1,000 units, find the product mix to yield maximum profits.

Solution:

Statement of Evaluation product A & B

Particulars	Product A		Product B	
	₹	₹	₹	₹
Sales		2,500		5,000
(-) Variable Costs:				
Materials Cost	500		1,250	
Direct labour	750		1,500	
Variable overhead	250	1,500	500	3,250
Contribution/unit		1,000		1,750

	Product A	Product B
1. P/V ratio = $\frac{C}{S} \times 100$	$= \frac{1,000}{2,500} \times 100$ = 40%	$= \frac{1,750}{5,000} \times 100$ = 35%
2. Material (Kg)/Unit	$= \frac{500}{50}$ = 10 kg	$= \frac{1,250}{50}$ = 25 kg
3. Contribution/kg of material	$= \frac{1,000}{10}$ = ₹ 100	$= \frac{1,750}{25}$ = ₹ 70
4. Labour Hrs./Unit	$= \frac{750}{30}$ = 25 hrs.	$= \frac{1,500}{30}$ = 50 Hrs.
5. Contribution/Labour Hr.	$= \frac{1,000}{25}$ = ₹ 40	$= \frac{1,750}{50}$ = ₹ 35

- (a) (i) Comment of the profitability of each product when total sales value is limited:
Product A has a higher P/V ratio than Product B, hence product A is more profitable.
- (ii) Comment on profitability of each product when raw material is in short supply:-
Product A has a higher contribution per kg raw materials than product B. Hence product A is more profitable.
- (iii) Comment on the profitability of each product when production capacity (labour) is the limiting factor:
Product A has a higher contribution per labour Hours than Product B. Hence product A is more profitable.
- (b) When raw materials and sales quantity both are limiting factors:

Statement of product Mix to yield maximum profits
(Availability of Raw Materials is limited to 20000 kg)

Products	Product A	Product B
Units to be made	1000	400
Raw material consumption	10,000 (1,000 units × 10 kg)	10,000 (400 units × 25 kg)
Contribution per Unit	₹ 1000	₹ 1,750
Total Contribution	₹ 10,00,000	₹ 7,00,000
Total contribution (A + B)	₹ 17,00,000	
(-) fixed Cost	₹ 10,00,000	
Profit	7,00,000	

Q.7. In a factory the standard mix consists of 60 kgs of X and 40 kgs of Y. The standard loss of production is 30%. The standard price of X is ₹ 5 per kg. and of Y ₹ 10 per kg.

The actual mixture and yield were as follows;

X :- 80 kgs at ₹ 4.50 per kg. Y :- 70 kgs at ₹ 8 per kg. Actual yield :- 115 kgs.

Calculate:

- Material Cost Variance
- Material Price Variance
- Material Revised Usage Variance
- Material Mix Variance, and
- Material Yield Variance.

Solution:

Materials	Standard			Actual			Std. Cost of Actual Mix		
	Kg	Rate	Total	Kg	Rate	Total	Kg	Rate	Total
X	90	5	450	80	4.50	360	80	5	400
Y	60	10	600	70	8.00	560	70	10	700
	150		1050	150		920			1100
Loss	45			35		–			
Output	105			115		920			1100

$$\text{Std. Rate of Std. Mix} = \frac{1050}{150} = ₹ 7 \text{ kg}$$

$$\text{Std. Rate of Actual Mix} = \frac{1100}{150} = 7.33$$

$$\text{Std. Cost of Std. Mix in terms of Actual yield} = \frac{1050}{105} \times 115 = 1150$$

Computation of Variances:

(a) Material Cost Variance

$$= \text{Actual Cost of Actual Mix} - \text{Std. Cost of Std. Mix in terms of actual mix}$$

$$= 920 - 1150 = 230 \text{ (F)}$$

(b) Materials price variance = AQ (SR – AR)

$$X = 80 (5 - 4.50) = 40 \text{ (F)}$$

$$Y = 70 (10 - 8.00) = 140 \text{ (F)}$$

$$180 \text{ (F)}$$

(c) Material revised Usage Variance

$$= \text{Actual Quantity} \times \text{Std. Rate of Actual Mix} = 1100$$

$$(-) \text{ Std. Cost of Std. Mix in terms of Actual yield} = \underline{1150}$$

$$50 \text{ (F)}$$

(d) Material Mix Variance =

$$\text{Actual Quantity} \times \text{Std. Rate of Actual Mix} = 1100$$

$$(-) \text{ Actual Quantity} \times \text{Std. Rate of Std. Mix} = \underline{1050}$$

$$50 \text{ (A)}$$

$$\begin{aligned}
 \text{(e) Material Yield Variance} &= \\
 \text{Actual Quantity} \times \text{Std. Rate of Std. Mix} &= 1050 \\
 \text{(-) Std. Cost of Std. Mix in terms of Actual yield} &= \underline{1150} \\
 &100 \text{ (F)}
 \end{aligned}$$

Reconciliation:

$$\begin{aligned}
 \text{MCV} &= \text{MPV} + \text{MMV} + \text{MYV} \\
 &= 180 \text{ (F)} + 50 \text{ (A)} + 100 \text{ (F)} \\
 &= 230 \text{ (F)}
 \end{aligned}$$

Q.8. V.N. Ltd. operates on a standard cost system to produce an article mixing two raw materials and following are the standards:-

40% of Material A at ₹ 4 per kg., 60% of Material B at ₹ 3 per kg.

A standard loss of 15% is expected in production.

The following actual cost data is given for March, 2010 (Production: 1700 kg of finished product):-

	Stock on 1.3.2010	Stock on 31.3.2010	Purchase for March, 2010	
			Kgs.	₹
Materials A	35 Kgs. (no. Variance)	5 kgs.	800	3,400
Materials B	40 Kgs. (no. Variance)	50 kgs.	1,200	3,000

Calculate the following variances in respect of the purchase during the month that are consumed :-

- Material Price Variance
- Material Mix Variance
- Material Yield Variance
- Material Cost Variance
- Material Usage Variance.

Solution:

Types of Materials	Standard			Actual		
	Qty	Rate	Amount	Qty	Rate	Amount
A	800	4	3,200	35	4.00	140.00
				795	4.25	3,378.75
B	1200	3	3,600	40	3.00	120.00
				1150	2.50	2,875.00
Total	2000		6,800	2020		6,513.75
Less Std. Loss 15%	300			320		
	1700		6,800	1700		6,513.75

(a) Materials Price Variances (MPV):

Material A: Since the actual price and standard price of 35 kg of Raw materials are the same, there will be no price variance in respect of this quantity. Price variance will be in respect of only 795 Kg as shown below:

$$AQ (SR - AR)$$

$$795 (4 - 4.25) = 198.75 (A)$$

Material B: Similarly, in respect of Material B, Price variance will be in respect of 1150 Kg only as shown below:

$$1150 (3 - 2.5) = 575 (F)$$

$$\text{Total MPV} = 198.75 (A) + 575 (F) = 376.25 (F)$$

(b) Material Usage Variance (MUV) = SR (SQ - AQ)

$$A = 4 (800 - 830) = 120 (A)$$

$$B = 3 (1200 - 1190) = \frac{30 (F)}{90 (A)}$$

(c) Material Yield Variance

= Std. Cost per Unit (Std. Output for Actual Mix - Actual output)

$$= 4 \left(\frac{1700}{2000} \times 2020 - 1700 \right)$$

$$= 4 \times (1717 - 1700)$$

$$= 4 \times 17 = 68 (A)$$

(d) Material Mix (MMV)

= Std. Rate (Revise std. Qty. - Actual Quantity)

Revise Std. Qty.

$$A = \frac{2020}{2000} \times 800 = 808$$

$$B = \frac{2020}{2000} \times 1200 = 1212$$

$$A = 4 \times (808 - 830) = 88 (A)$$

$$B = (1212 - 1190) \times 3 = \frac{66 (F)}{22 (A)}$$

(e) Material Cost Variance (MCV)

= Std. Cost for Actual output - Actual cost

$$= 6800 - 6513.75$$

$$= 286.25 (F)$$

Verification:

$$\text{MCV} = \text{MUV} + \text{MPV}$$

$$= 90(A) + 376.25 (F) = 286.25 (F)$$

$$\text{MUV} = \text{MMV} + \text{MYV}$$

$$= 22(A) + 68(A) = 90A$$

Working Notes:

1. The Std. Loss being 15% it means to produce 1700 Kg. of article, std. Quantity of material required is

$$\frac{100}{85} \times 1700 \text{ Kg.} = 20000 \text{ Kg.}$$

$$A = 40\% \text{ of } 2000 = 800$$

$$B = 60\% \text{ of } 2000 = 1200$$

$$2. \text{ Std. Cost per unit} = \frac{\text{Total Std. Cost}}{\text{Std. output}} = \frac{6800}{1700} = ₹ 4/\text{unit}$$

Q.9. The following are the estimated sales of a company for eight months ending 30. 11.2008

Months		Estimated Sales (Units)
April	2008	12,000
May	2008	13,000
June	2008	9,000
July	2008	8,000
August	2008	10,000
September	2008	12,000
October	2008	14,000
November	2008	12,000

As a matter of policy, the company maintains the closing balance of finished goods and raw materials as follows :-

Stock Items**Closing balance of a month**

Finished goods 50% of the estimated sales for the next month

Raw Materials Estimated consumption for the next month.

Each unit of production requires 2 kg. of raw material costing ₹ 5 per kg.

Prepare Production Budget (in units) and Raw Material Purchase Budget (in units and cost) of the company for the half year ending 30th September, 2008.

Production Budget (in Units)**For the half year ending 30th Sept 2008**

Month	Sales in Units	Closing Bal. 50% of estimated sales for next month	Opening bal.	Production (2 + 3 - 4)
April	12,000	6,500	6,000	12,500
May	13,000	4,500	6,500	11,000
June	9,000	4,000	4,500	8,500
July	8,000	5,000	4,000	9,000
Aug.	10,000	6,000	5,000	11,000
Sept.	12,000	7,000	6,000	13,000
	64,000			65,000

Purchase Budget (in Cost and Units)
For the half year ending 30th Sept. 2008

Month	Production in Units	Consumption Kg. ₹ 2/- per unit	Closing Balance	Opening Balance	Purchase in Kg.	Rate	Amount
April	12,500	25,000	22,000	25,000	22,000	5	1,10,000
May	11,000	22,000	17,000	22,000	17,000	5	85,000
June	8,500	17,000	18,000	17,000	18,000	5	90,000
July	9,000	18,000	22,000	18,000	22,000	5	1,10,000
Aug	11,000	22,000	26,000	22,000	26,000	5	1,30,000
Sept.	13,000	26,000	26,000	26,000	26,000	5	1,30,000
	65,000	1,30,000		1,30,000			6,55,000

Q.10. X Ltd. furnishes you the following particulars:-

Product X requires 20 hours per unit

Standard rate per hour is ₹ 2

Units produced: 4,000

Hours taken 76,000 (including 200 hours for power failure) at ₹ 2.10 per hour.

Calculate :-

- (i) Direct Labour Cost Variances
- (ii) Direct Labour Rate Variances
- (iii) Direct Labour Efficiency Variances
- (iv) Direct Labour Idle Time Variances

Solution:

$$\begin{aligned}
 \text{(i) Labour Cost Variance (LCV)} &= (\text{SCL} - \text{ACL}) \\
 &= (4,000 \times 2 \times 20 - 76,000 \times 2.10) \\
 &= 1,60,000 - 1,59,000 = 400 \text{ (F)} \\
 \text{(ii) Labour Rate Variance} &= \text{Actual Hours (SR - AR)} \\
 &= 76,000 (2 - 2.10) = 7,600 \text{ (A)} \\
 \text{(iii) Labour Efficiency Variance} &= \text{SR (SH - AH)} \\
 &= 2 (80,000 - 75,800) \\
 &= 8,400 \text{ (F)} \\
 \text{(iv) Labour Idle Time Variance} &= \text{Idle time} \times \text{Std. Rate} \\
 &= 200 \times 2 = 400 \text{ (F)}
 \end{aligned}$$

Verification:

$$\begin{aligned}
 \text{LCV} &= \text{LRV} + \text{LEV} + \text{LITV} \\
 400 \text{ (F)} &= 7,600 \text{ (A)} + 8,400 \text{ (F)} + 400 \text{ (A)}
 \end{aligned}$$

Q.11. From the following data of a concern, find out the Fixed Costs, P/V ratio and Break-even Sales :-

	Sales (₹)	Profit (₹)
First half-year	14,433	385
Second half-year	18,203	1,139

Also calculate:

- (i) Profit or Loss at sales of ₹ 12,000.
- (ii) Sales required to earn a profit of ₹ 2,000.
- (iii) Margin of safety at sales of ₹ 24,000.

Solution:

Particulars	First half	Second half	Difference
Sale (₹)	14,433	18,203	3,770
Profit (₹)	385	1,139	754
Total Cost	14,048	17,064	3,016

$$(i) \text{ P/V Ratio} = \frac{\text{Change in profit}}{\text{Change in Sales}} \times 100$$

$$= \frac{754}{3,770} \times 100 = 20\%$$

$$(ii) \text{ Fixed Cost} = \text{Sales} - \text{VC} - \text{Profit}$$

$$2,502 = 14,433 - 11,546 - 385$$

$$(iii) \text{ BES} = \frac{\text{FC}}{\text{P/V Ratio}}$$

$$= \frac{2,502}{20\%} = 12,510$$

Further Calculation:

- (i) Profit or loss at sales of ₹ 12,000

$$\text{Sales} = \frac{\text{F} + \text{P}}{\text{P/V Ratio}}$$

$$12,000 = \frac{2,502 + \text{P}}{20\%}$$

$$2,400 = 2,502 - \text{P}$$

$$\text{or profit/Loss} = 2,400 - 2,502$$

$$\text{Loss} = (102)$$

- (ii) Sale required to earn a profit of ₹ 2,000

$$\text{Sales} = \frac{\text{F} + \text{P}}{\text{P/V Ratio}}$$

$$= \frac{2,502 + 2,000}{20\%}$$

$$= \frac{4,502}{20\%} = ₹ 22,510$$

- (iii) MoS at a sale of ₹ 24,000

$$\text{MoS} = \text{Actual Sales} - \text{BE Sales}$$

$$= 24,000 - 12,510$$

$$= 11,490$$

Or

$$= \frac{11,490}{24,000} \times 100$$

$$= 47,875\% \text{ of sale.}$$

Q.12. A company manufacturing a particular product the standard direct materials cost of which is ₹ 10 per unit. The following information is obtained from the costing records:-

(a) Standard Mix:

Material	Quantity (Units)	Rate (₹)	Amount (₹)
A	70	10	700
B	30	5	150
	100		850
Loss: (15%)	15		—
	85		850

(b) Actual results for June, 2008:

Material	Quantity (Units)	Rate (₹)	Amount (₹)
A	400	11	4,400
B	200	6	1,200
	600		5,600
Loss: (10%)	60		—
	540		5,600

Compute:

- (i) Total Material Cost Variance;
- (ii) Material Price Variance;
- (iii) Material Mix Variance;
- (iv) Material Yield Variance;
- (v) Material Usage Variance;

Solution:**Calculation of Variances :****(i) Total Material Cost Variance :**

$$\begin{aligned} &\text{Std. Cost for Actual output} - \text{Actual cost} \\ &= 540 \times 10 - 5,600 = 200 \text{ (A)} \end{aligned}$$

(ii) Material Price Variance :

$$AQ (SR - AR)$$

$$A = 400 (10 - 11) = 400 \text{ (A)}$$

$$B = 200 (5 - 6) = \underline{200 \text{ (A)}}$$

$$600 \text{ (A)}$$

(iii) Material Mix Variance (MMV) :

$$SR (\text{Revised Std. Quantity} - \text{Actual Quantity})$$

$$\begin{aligned} \text{A: } 10 (420 - 400) &= 200 \text{ (F)} \\ \text{B: } 5 (180 - 200) &= \underline{100 \text{ (A)}} \\ \text{Total} &= 100 \text{ (F)} \end{aligned}$$

(iv) Material Yield Variance (MYV):

Std. Cost per unit (Std. output for Actual mix – Actual output)

$$10 (510 - 540) = 300 \text{ (F)}$$

(v) Material Usage Variance :

SR (SQ – AQ)

$$\text{A} = 10 \left(\frac{7,560}{17} - 400 \right) = 447 \text{ (F)}$$

$$\text{B} = 5 \left(\frac{3,240}{17} - 200 \right) = \underline{47 \text{ (A)}}$$

$$\text{Total} = 400 \text{ (F)}$$

Verification:

$$\begin{aligned} \text{MCV} &= \text{MPV} + \text{MUV} \\ &= 600 \text{ (A)} + 400 \text{ (F)} = 200 \text{ (A)} \end{aligned}$$

$$\begin{aligned} \text{MUV} &= \text{MMV} + \text{MYV} \\ &= 100 \text{ (F)} + 300 \text{ (F)} = 400 \text{ (F)} \end{aligned}$$

Working Notes:**1. Std. quantity for Actual Output**

$$= \frac{\text{Std. Quantity}}{\text{Std. Output}} \times \text{Actual output}$$

$$\text{Material A: } \frac{70}{85} \times 540 = \frac{7,560}{17} \text{ Units}$$

$$\text{B: } \frac{30}{85} \times 540 = \frac{3,240}{17} \text{ Units}$$

2. Revised Std. Quantity

$$= \frac{\text{Std. Quantity}}{\text{Std. Output}} \times \text{Actual Mix}$$

$$\text{Material A: } \frac{70}{100} \times 600 = 420 \text{ Units}$$

$$\text{B: } \frac{30}{100} \times 600 = 180 \text{ Units}$$

3. Std. Output for Actual Mix

$$= \frac{\text{Std. Output}}{\text{Std. Mix}} \times \text{Actual Mix}$$

$$= \frac{85}{100} \times 600 = 510 \text{ Units}$$

- Q.13. Write short note of the following:
Difference between 'Fixed' and 'Flexible' budget

Solution:

Difference between 'Fixed' and 'Flexible' budget: A budget may be flexible or fixed depending upon its capacity to change according to change in the level of activity. The main differences between Flexible Budget and Fixed Budget are as follows:

Fixed Budget	Flexible Budget
1. Definition: It is a Budget desired to remain unchanged irrespective of the level of activity actually attained.	It is a Budget, which by recognising the difference between fixed, semi-variable and variable costs is designed to change in relation to level of activity attained.
2. Rigidity: It does not change with actual volume of activity achieved. Thus it is known as a Rigid or Inflexible budget.	It can be re-casted on the basis of activity level to be achieved. Thus it is not rigid.
3. Level of Activity: It operates on one level of activity and under one set of conditions. It assumed that there will be no change in the prevailing conditions, which is unrealistic.	It consists of various budgets for different levels of activity.
4. Effects of Variance Analysis: Variance Analysis does not give useful information as all costs (fixed variable and semi-variable) are related to only one level of activity.	Variance Analysis provides useful information as each cost is analysed according to its behaviour.
5. Use of Decision Making: If the budgeted and actual activity levels differ significantly, then aspects like cost ascertainment and price fixation do not give a correct picture	It facilitates the ascertainment of cost, fixation of selling price and submission of quotations.
6. Performance Evaluation: Comparison of actual performance with budgeted targets will be meaningless, especially when there is a difference between two activity levels.	It provides a meaningful basis of comparison of the actual performance with the budgeted targets.

- Q.14. From the following particulars, you are required to calculate:

- (i) PV ratio
- (ii) B.E.P. for sales
- (iii) Margin of safety
- (iv) Profit when sales are ₹ 2,00,000/-
- (v) Sales required to earn net profit of ₹ 40,000/-

Year	Sales (₹)	Profit (₹)	Units
I	2,40,000	18,000	24,000
II	2,80,000	26,000	28,000

Solution:

	Year I	Year I	Difference
Sales	2,40,000	2,80,000	40,000
Profit	18,000	26,000	8,000

$$(i) \text{ P/V ratio} = \frac{\text{Change in profit during 2 years}}{\text{change in sales during the period}} \times 100$$

$$= \frac{8,000}{40,000} \times 100 = 20\%$$

$$(ii) \text{ B.G.P. (Sales)} = \frac{\text{F. Cost}}{\text{P/L ratio}}$$

$$\begin{aligned} \text{Fixed cost} &= \text{Contribution} - \text{profit} \\ &= 2,40,000 \times 20\% - 18,000 \\ &= 48,000 - 18,000 = 30,000 \end{aligned}$$

$$\text{B.G.P.} = \frac{30,000}{20\%} = ₹ 1,50,000$$

$$\text{B.G.P. (Unit)} = \frac{1,50,000}{10} = 15,000 \text{ Units}$$

$$(iii) \text{ Margin of Safety : } A - \text{BES}$$

$$\text{1st year : } 24000 - 15,000 = 9,000 \text{ units}$$

$$\text{2nd year : } 28,000 - 15,000 = 13,000 \text{ units}$$

$$(iv) \text{ Profits = ? When sales = 2,00,000}$$

$$\text{Sales} = \frac{\text{F} + \text{P}}{\text{P/V ratio}}$$

$$\text{Sales} = \frac{30,000 + \text{P}}{20\%}$$

$$\text{Or } \text{P} = 40,000 - 30,000 = ₹ 10,000$$

$$(v) \text{ Sales = ? When Profit = 40,000}$$

$$\text{Required Contribution} = \text{F} + \text{P}$$

$$= 30,000 + 40,000 = 70,000$$

$$\text{Sales} = \frac{70,000}{20\%} = ₹ 3,50,000$$

Q.15. The standard cost of certain chemical mixture is as follows:

Material	Cost per tonne (₹)	
I (40%)	20	A standard loss of 10% is expected in production.
II (60%)	30	

For a period, the actual consumption data was as follows:

Material	Cost per tonne (₹)	
I (180 tonnes)	18	The actual weight produced was 364 tonnes
II (220 tonnes)	34	

Calculate all the Material variances.

Solution:

Calculation of Material Variances

Basic Calculations:

₹

M1: Actual cost of Material used:

A	180 tonnes × 18	=	
B	220 tonnes × 34	=	10,720

M2: Standard cost of Material used:

A	180 × 2	=	3,600
B	220 × 30	=	<u>6,600</u> 10,200

M3: Std. Cost material, if cost had been used in Std. Proportions:

$$\begin{aligned} \text{Material A} &= \frac{\text{Std. Qty. of material A in kg.} \times \text{Weight in}}{\text{Weight of Std. 5 Actual mix}} \times \text{SR of A} \\ &= \frac{40}{100} \times 400 \text{ kg} \times 20 = 3,200 \quad \dots\dots\dots(i) \end{aligned}$$

Std. Quality of Material B in

$$\text{Material B} = \frac{60}{100} \times 400 \text{ kg} \times 30 = 7,200 \quad \dots\dots\dots(ii)$$

$$\begin{aligned} \text{M3} &= (i) + (ii) \\ &= 3,200 + 7,200 \\ &= ₹ 10,400 \end{aligned}$$

Std. Cost of output

Let us find out the Std. Cost, when input is 100kg.

Std. Mix	SR	SC
40 kg	20	800
<u>60 kg</u>	30	<u>1,800</u>
100 kg		2,600
Less 15% <u>10 kg</u>		<u> </u>
90 kg		2,600

$$\begin{aligned} \text{Std. Cost of Actual output of 364 kg} &= \frac{2,600}{90} \times 364 \\ &= 10,516 \end{aligned}$$

Computation of Variances:

(a) Material price variance	=	M1 – M2	
	=	10,720 – 10,200	= 520 (A)
(b) Material usage variance	=	M2 – M4	
	=	10,200 – 10,516	= 316 (A)
(c) Material mix variance	=	M2 – M3	
	=	10,200 – 10,400	= 200 (F)
(d) Material yield variance	=	M3 – M4	
	=	10,400 – 10,516	= 116 (F)
(e) Material cost variance	=	M1 – M4	
	=	10,720 – 10,516	= 204 (A)

OR

$$\begin{aligned}
 \text{MCV} &= \text{MPV} + \text{MWV} \\
 &= 520 \text{ (A)} + 316 \text{ (F)} \\
 &= 204 \text{ (A)}
 \end{aligned}$$

OR

$$\begin{aligned}
 \text{MPV} + \text{MUV} + \text{MYU} \\
 &= 520 \text{ (A)} + 200 \text{ (F)} + 116 \text{ (F)} \\
 &= 204 \text{ (A)}
 \end{aligned}$$

Q.16. The standard material cost to produce one ton (1,000 kgs.) of chemical "X" is :-

300 kg of material A @ ₹ 10 per kg.

400 kg of material B @ ₹ 5 per kg.

500 kg of material C @ ₹ 6 per kg.

During the month of December 2010, 100 tons of mixture "X" were produced from the usage of :-

35 tons of materials A at a cost of ₹ 9,000 per ton

42 tons of material B at a cost of ₹ 6,000 per ton

53 tons of material C at a cost of ₹ 7,000 per ton

You are required to calculate:-

- Material Cost Variance
- Material Price Variance
- Material Usage Variance
- Material Mix Variance

Solution:**Chemical 'X'**

Standard				Actual			
Material	Qty. (Kg.)	Rate (₹)	Amt (₹)	Material	Qty. (Kg.)	Rate (₹)	Amt (₹)
A	30,000	10	3,00,000	A	35,000	9	3,15,000
B	40,000	5	2,00,000	B	42,000	6	2,52,000
C	50,000	6	3,00,000	C	53,000	7	3,71,000
Total	1,20,000	-	8,00,000	Total	1,30,000		9,38,000

(A) Material Cost Variance

= Standard cost for actual output – actual cost
 = 8,00,000 – 9,38,000 = ₹ 1,38,000 (A)

(B) Material Price Variance

= Actual Quantity (standard rate - actual rate)

Material A = 35,000 (10-9) = ₹ 35,000 (F)

Material B = 42,000 (5-6) = ₹ 42,000 (A)

Material C = 53,000 (6-7) = ₹ 53,000 (A)

Total = ₹ 60,000 (A)

(C) Material Usage Variance: (standard quantity for actual)

Material = (30,000 - 35,000) × 10 = 50,000

Material = (40,000 - 42,000) × 5 = 10,000

Material = (50,000 - 53,000) × 6 = 18,000

Total = 78,000

(D) Material Mix Variance:

(Revised standard quantity - actual quantity) × standard rate

Material = (32,000 – 35,000) × 10 = ₹ 25,000 (A)

Material = (1,30,000/3 - 42,000) × 5 = ₹ 6,667 (F)

Material = (16,250/3-53,000) × 6 = ₹ 7,000 (F)

Total = ₹ 11,333 (A)

Working Note:

$$\text{Revised Std. Qty.} = \frac{\text{Total actual weight of mix} \times \text{Std. Qty.}}{\text{Total actual weight of mix}}$$

Material (A)	Material (B)	Material (C)
32,500 kg.	4,333 kg.	54,167 kg.
(1,30,000/1,20,000× 30,000)	(1,30,000/1,20,000× 40,000)	(1,30,000/1,20,000× 50,000)

Q.17. From the following information, you are asked to compute

- Break-even point in value and volume
- PN ratio
- Margin of safety, both in absolute and percentage terms

	₹
Sales value	20,00,000
Material cost	4,00,000
Labour cost	5,00,000
Variable manufacturing expenses	1,00,000
Variable selling and distribution expenses	2,00,000
Repairs and maintenance (Fixed).	90,000
Depreciation, rates and taxes	30,000
General and administrative expenses:	
Salary	₹
Factory supervisor	12,000
Office manager	18,000
Other office employees	<u>60,000</u>
	<u>90,000</u>
Salesmen's Commission	5% of sales
(not included in selling and distribution expenses)	
Selling price per unit	100/-
Fixed selling Distribution Overheads	1,90,000

Solution:

Total No. of units sold = ₹ 20,00,000 / ₹ 1000 = 20,000 Units

Selling Price per unit = ₹ 100

Variable Cost	₹
Material Cost	4,00,000
Labour Cost	5,00,000
Mfg. Cost	1,00,000
Selling and Discounts Cost	<u>2,00,000</u>
	12,00,000

Variable Cost per unit = ₹ 12,00,000/20,000 unit = ₹ 60 p.m.

Also, salesman's commission per unit = ₹ 5

Total receivable cost per unit = 60 + 5 = ₹ 65/-

Selling price per unit – Variable cost per unit

Contribution per unit = 100 – 65 = 35

(i) Break-even point

Units	Contribution	
1	35	BEP is terms of sale value = 14,000 units
?	49,000	= units × 100 = 14,00,000

(ii) P/V ratio = contribution/Sales × 100 = 35/100 × 100 = 35%

(iii) Margin of safety = Actual Sales – BEP Sales
 = 20,000 units – 14,000 units
 = 6,000 units
 = 6,000 × 100 = ₹ 6,00,000

(Alt = 20,00,000 less / 40,0000 = ₹ 6,00,000)

$$\begin{aligned} \text{(iv) Margin of safety ratio} &= \text{M/s. Sales/ Sales} \times 100 \\ &= 6,000/20,000 \times 100 = 30\% \end{aligned}$$

Q.18. The expenses budgeted for production of 10,000 units in a factory are furnished below:-

	Per Unit (₹)
Materials	70
Labour	25
Variable overheads	20
Fixed overheads	10
Variable overheads (Direct)	5
Selling Expenses (10% Fixed)	13
Distribution expenses (20% Fixed)	7
Administrative expenses (Fixed)	5
Total cost of sale per unit	155

Prepare a budget for production of 8,000 units (with total and per unit details).

Solution:

Flexible Budget

Variable cost	8000 units	₹ Per unit
Material	5,60,000	70
Labour	2,00,000	25
Var. 0 +1	1,60,000	20
Var. 0 + 1 (Direct)	40,000	5
Selling Exp. (90%)	93,600	11.7 (13 – 1.30)
Distribution Exp. (80%)	44,800	5.6 (7 – 1.40)
A	10,98,400	137.3

Fixed cost		
Fixed overheads (10000 u @ 10%-)	1,00,000	12.5
Selling Exp. (10% 10000 u @ 1.30)	13,000	1.63
Dist. Exp. (10000 u @ 14/-)	14,000	1.73
Admin. 0/+1 (10000 u @ 50/-)	50,000	6.25
Total Fined Cost (B)	1,77,000	22.13
Total Cost A + B	12,75,400	159.43

Q.19. A Factory is currently working at 50% capacity and produces 30,000 units and also sold each at ₹ 225 per unit. Prepare a Flexible Budget and estimate the profit of the company when it works to 75% and 90% capacity. Assume that all units produced are sold at the same selling price per unit as shown above.

Following information is provided to you:-

(i) Variable Expenses:

Materials	₹ 60 per unit
Labours	₹ 40 per unit
Other Expenses	₹ 15 per unit

(ii) Semi-variable Expenses: (at 50% capacity)

Indirect Labour	₹ 1,50,000
Indirect Materials	₹ 2,10,000
General Administrative Expenses	₹ 2,70,000
Repairs and Maintenance	₹ 1,20,000
Salesmen Salaries	₹ 1,80,000

(iii) Fixed Expenses:

Office and Management Salaries	₹ 5,40,000
Office and Factory Rent and Taxes	₹ 6,00,000
Sundry Administrative Expenses	₹ 7,20,000
Depreciation on Machinery and Furniture	₹ 4,50,000

(iv) Semi-variable expenses remain constant up to 60% of capacity, increasing by 10% between 60% and 80% capacity and by 20% between 80% and 100% capacity.

(v) Rate per unit of variable expenses remains same.

Solution:

Flexible Budget

	30,000 units 50%	45,000 units 75%	54,000 units 90%
(i) Variable Expenses	₹	₹	₹
Materials	18,00,000	27,00,000	32,40,000
Labours	12,00,000	18,00,000	21,60,000
Other Expenses	4,50,000	6,75,000	8,10,000
(ii) Semi-variable Expenses			
Indirect labour	1,50,000	1,65,000	1,80,000
Indirect materials	2,10,000	2,31,000	2,52,000
General administrative expo	2,70,000	2,97,000	3,24,000
Repairs and Maintenance	1,20,000	1,32,000	1,44,000
Salesman salaries	1,80,000	1,98,000	2,16,000
(iii) Fixed Expenses			
Office and Management salaries	5,40,000	5,40,000	5,40,000
Office and Factory rent and taxes	6,00,000	6,00,000	6,00,000
Sundry Administrative expenses	7,20,000	7,20,000	7,20,000
Dep. on machinery and furniture	4,50,000	4,50,000	4,50,000
Total Cost	66,90,000	85,08,000	96,36,000

	₹ (30,000 × 225)	₹ 45,000 × 225	₹ 54000x225
Sales	67,50,000	1,01,25,000	1,21,50,000
Less total cost	66,90,000	85,08,000	96,36,000
Profit :	60,000	16,17,000	25,14,000

Q.20. A gang of workers normally consists of 30 men, 15 women and 10 boys. They are paid at standard rates per hour as, Man ₹ 80.00 woman ₹ 60.00 and Boy ₹ 40. In a normal working of a week of 40 hours. The gang is expected to produce 2000 units of output.

During the week ended 31st December, 2011, the gang consisted of 40 men, 10 women and 05 boys. The actual wages paid per hour were Man ₹ 70.00, woman ₹ 65.00 and Boy ₹ 30.00. Actual units produced by the gang 1600 units.

Calculate:-

- (i) Labour Cost Variance
- (ii) Labour Rate Variance
- (iii) Labour Efficiency variance
- (iv) Labour Mix Variance
- (v) Labour Yield Variance

Solution:

(i) Labour Cost Variance

(Std. Rate × Std. time for actual output) – (Actual Rate × Actual time)

$$\begin{aligned} \text{Men} &= (80 \times 960) - (70 \times 1600) \\ &= (76800 - 1,12,000) &= ₹ \quad 35,200 \text{ (A)} \end{aligned}$$

$$\begin{aligned} \text{Women} &= (60 \times 480) - (65 \times 400) \\ &= (28,800 - 26,000) &= ₹ \quad 2,800 \text{ (F)} \end{aligned}$$

$$\begin{aligned} \text{Boys} &= (40 \times 320) - (30 \times 200) \\ &= (12,800 - 6000) &= ₹ \quad 6,800 \text{ (F)} \end{aligned}$$

$$\text{Labour Cost Variance} = ₹ \quad \underline{\underline{25,600 \text{ (A)}}}$$

(ii) Labour Rate Variance: Actual time (SR – AR)

$$\text{Men} = 1600 (80 - 70) = ₹ \quad 16,000 \text{ (F)}$$

$$\text{Women} = 400 (60 - 65) = ₹ \quad 2,000 \text{ (A)}$$

$$\text{Boys} = 200 (40 - 30) = ₹ \quad 2,000 \text{ (F)}$$

$$\text{Labour Rate Variance} = ₹ \quad \underline{\underline{16,000 \text{ (F)}}}$$

(iii) Labour Efficiency Variance:

= Std. price (Std. time for actual output - actual time)

$$\begin{aligned} \text{Men} &= 80 \{960 - 1600\} \\ &= 80(640) &= ₹ \quad 51,200 \text{ (A)} \end{aligned}$$

$$\begin{aligned} \text{Women} &= 60 (480 - 400) \\ &= 60 (80) &= ₹ \quad 4,800 \text{ (F)} \end{aligned}$$

$$\begin{aligned} \text{Boys} &= 40 (320 - 200) \\ &= 40 (120) &= ₹ \quad 4,800 \text{ (F)} \end{aligned}$$

$$\text{Labour Efficiency Variance} = ₹ \quad \underline{\underline{41,600 \text{ (A)}}}$$

(iv) Labour Mix Variance:

	= Std. Rate (Std. Time – Actual time worked)	
	= 80 (1200 – 1600)	
	= 80(400)	= ₹ 32,000 (A)
Women	= 60 (600 – 400)	
	= 60 (200)	= ₹ 12,000 (F)
Boys	= 40 (400 – 200)	
	= 40(200)	= ₹ 8,000 (F)
	Labour Mix Variance	= ₹ 12,000 (A)

(v) Labour Yield Variance:

	= Std. Labour cost per unit of output × (Std. Output for Actual time – Actual output)	
	= 4 (2000 – 1600)	
	= 74 (400)	= ₹ 29,600 (F)

Working Notes:**1. Actual time:**

Men	= 40 × 40	= 1600
Women	= 10 × 40	= 400
Boys	= 05 × 40	= 200
		2200 hrs

2. Std. Time for actual output:

Men	= $\frac{1600}{2000} \times (30 \times 40)$	= 960 hrs.
Women	= $\frac{1600}{2000} \times (15 \times 40)$	= 480 hrs.
Boy	= $\frac{1600}{2000} \times (10 \times 40)$	= 320 hrs.

3. Std. Time:

Men	= 30 × 40	= 1200 hrs.
Women	= 15 × 40	= 600 hrs.
Boys	= 10 × 40	= 400 hrs.

4. Std. Labour cost permit of output:

Std. Output given = 2000 units

Std. Cost given

Men	= 30 × 40 × 80	= 96000
Women	= 15 × 40 × 60	= 36000
Boys	= 10 × 40 × 40	= 16000
		1,48,000

So, labour cost permit of output

$$= \frac{1,48,000}{2000} = ₹ 74/-$$

Std. Output for actual time worked for 2200 hours of total.

Std. Output = 2000 units

for 1760 hrs. of actual time worked

$$= 2000 \times \frac{1,760}{2,200} = 1600 \text{ units}$$

Q.21. A company manufactures a single product with a capacity of 2,50,000 units per annum. The summarised profitability statement for the year ended 31st March, 2012 is as under:

Particulars		₹	₹
Sales (1,50,000 units @ 20 ₹ Per unit)			30,00,000
Cost of sales:			
Direct Materials		6,00,000	
Direct Labour		4,50,000	
Production Overheads:			
Variable		1,50,000	
Fixed		4,00,000	
Administrative Overheads Fixed		3,00,000	
Selling and Distribution Overheads			
Variable		3,00,000	
Fixed		2,00,000	24,00,000
Profit			6,00,000

(a) You are required to calculate:

- (i) P/N Ratio
- (ii) Break Even Sales

(b) You are also required to evaluate the following options :-

- (i) What will the amount of sales required to earn target profit of 20% on sales, in the packing is improved at an additional cost of ₹ 2 per unit?
- (ii) If an expenditure of ₹ 4,00,000 is made on advertising, the sales would increase from the present level of 1,50,000 units to 2,00,000 units at a selling price of ₹ 21 per unit. Will that expenditure be justified?
- (iii) If selling price is reduced by ₹ 2 per unit, there will be 100% capacity utilisation. Will the reduction in selling price be justified?

Solution:

Sales		30,00,000
Less: Variable cost		
Direct materials	6,00,000	
Direct labour	4,50,000	
Variable cost	<u>4,50,000</u>	<u>15,00,000</u>
Contributions		<u>15,00,000</u>

(a) (i) P/V Ratio

$$\begin{aligned}
 &= \frac{\text{Contribution}}{\text{Sales}} \times 100 \\
 &= \frac{15,00,000}{30,00,000} \times 100 \\
 &= 50\%
 \end{aligned}$$

(ii) Break Even Sales

$$\begin{aligned}
 &= \frac{\text{Fixed cost}}{\text{P/V Ratio}} \\
 \text{Fixed cost} &= 4,00,000 + 3,00,000 + 2,00,000 \\
 &= 9,00,000 \\
 &= \frac{9,00,000}{50\%} \\
 &= 18,000
 \end{aligned}$$

(b) (i) Contribution = Fixed cost + Derived profit

$$\begin{aligned}
 \text{Additional cost} &= 1,50,000 \times 2 &= 3,00,000 \\
 \text{Fixed cost} &= 9,00,000 + 3,00,000 &= 12,00,000 \\
 \text{Contribution} &= 12,00,000 + 6,00,000 &= 18,00,000 \\
 \text{No. of units} &= \frac{18,00,000}{10} \\
 &= 1,80,000 \text{ units}
 \end{aligned}$$

$$\begin{aligned}
 \text{(ii) Sales (2,00,000} \times 21) &= 42,00,000 \\
 \text{Less: variable cost (15,00,000} + 4,00,000) &= 19,00,000 \\
 \text{Contribution} &= \underline{\underline{23,00,000}}
 \end{aligned}$$

$$\begin{aligned}
 \text{P/V ratio} &= \frac{25,00,000}{42,00,000} \times 100 \\
 &= 54.76\%
 \end{aligned}$$

B. E. P. sales

$$\begin{aligned}
 &= \frac{\text{Fixed cost}}{\text{P/V Ratio}} \\
 &= \frac{9,00,000}{54.76\%} \\
 &= ₹ 16435.35
 \end{aligned}$$

Expenditure is justified because P/V Ratio is more as compared to former sales.

(iii) Selling price is reduced by ₹ 2/-

$$\begin{aligned}
 \text{New S.P.} &= 20 - 2 ₹ 18/- \\
 \text{Sales (1,50,000} \times 18) &= 27,00,000 \\
 \text{Less: Variable cost} &= 15,00,000 \\
 \text{Contribution} &= \underline{\underline{12,00,000}}
 \end{aligned}$$

$$\begin{aligned} \text{P/V ratio} &= \frac{\text{Contribution}}{\text{Sales}} \times 100 \\ &= \frac{12,00,000}{27,00,000} \times 100 \\ &= 44.44\% \\ \text{B.E.P. (sale)} &= \frac{\text{Fixed cost}}{\text{P/V Ratio}} \\ &= \frac{9,00,000}{44.44\%} \\ &= 20252/- \end{aligned}$$

Note: Although P/V Ratio is reduced, B.E.P. (sale) has increased and hence it is justified.

April 2013

Duration : 2 Hrs.

Total Marks: 60

- N.B. :** 1. Question Nos. 1 and 2 are **compulsory**.
2. Attempt any **one** question from Question Nos. 3 and 4.
3. Attempt any **one** question from Question Nos. 5 and 6.
4. **Figures** to the **right** indicate **marks** assigned to the questions.
5. **Working notes** should form **part of your answer**.

1. From the following data of M/s. ABC Ltd.

[15]

Year	Sales ₹	Profit ₹
2011	6,00,000	20,000
2012	8,00,000	60,000

Calculate :

- (a) P/V Ratio.
- (b) Break Even Point (Value).
- (c) Margin of safety for both years (value).
- (d) Profit when sales ₹ 7,00,000.
- (e) Sales to earn the profit of ₹ 65,000.
2. (a) State whether the following statements are True or False Rewrite : (5)
- (i) Variable Cost per unit goes on decreasing with increase in volume of production.
- (ii) Negative standard is not a type of standard.
- (iii) When fixed cost increases, the BEP increases.
- (iv) If the activity level is reduced from 80% to 70% the fixed cost per unit will decrease.
- (v) Marginal cost technique is used for make or buy decision.
- (b) Fill in the blanks with most appropriate word / words and rewrite : (5)
- (i) Material Cost Variance = Material Price Variance + _____.
- (ii) When sales increases the Break Even Point _____.
- (iii) _____ budget gives a summary of all functional budgets.
- (iv) Telephone expenses is the example of _____ cost.
- (v) Historical cost means the _____ cost incurred in the past.
- (c) Match the column rewrite: (5)

Group 'A'	Group 'B'
(i) Raw Material	(a) Not Controllable in Short Run
(ii) Key Factor	(b) Necessary for all Business

(iii) Master Budget	(c) Variable Cost
(iv) Fixed Cost	(d) Opportunity Cost
(v) Variance	(e) Important for Decision Making
	(f) Deviation from Standard Cost

3. **KBC Manufacturing Company produces 7,500 units by utilising its 75% capacity, supplies you the following cost information:** [15]

Cost information at 75%. Capacity utilisation (7,500 units)

Particulars	₹
Direct Materials	7,50,000
Direct Labour	6,00,000
Direct Expenses	3,00,000
Office Overheads	4,50,000
Selling Overheads	3,00,000
	1,50,000

Additional Information:

- Direct materials, Direct labour, Direct expenses are variable cost.
- Factory overheads per unit increases by 10%, if capacity utilisation goes down below the 75% and decreases by 10%, if capacity utilisation goes up above the 75%.
- Office overheads are fixed overheads.
- Selling overheads per unit increases by 20%, if capacity utilisation goes down below 75% and decreases by 20%, if capacity utilisation goes up above the 75%.
- It is the policy of the company to charge profit at 25% on cost.

You are required to prepare a Flexible Budget at 50%, 80% and 100% capacity utilisation.

OR

4. **The following information is available from the records of Anandsagar Co. Ltd. for April, 2013.** [15]

Particulars	Budget	Actual
Fixed Overheads for April, 2013	₹ 20,000	₹ 24,000
Production in Units (April, 2013)	4,000	4,200
Standard Time Per Unit (Hours)	10	–
Actual Hours Worked in April, 2013	–	44,000

Calculate:

- Fixed Overhead Cost Variance.
- Fixed Overhead Expenditure Variance.
- Fixed Overhead Volume Variance.
- Fixed Overhead Capacity Variance.
- Fixed overhead Efficiency Variance.

5. The following information in respect of Product A and B of XYZ Co. Ltd. is obtained: [15]

Particulars	Products	
	A	B
Sales Price	2,000	1,200
Direct Material	1,400	800
Direct Labour Hours (7 4 Per Hour)	20 Hrs.	40 Hrs.
Variable Overheads	100% of Direct Wages	80% of Direct Wages

Fixed overheads are 50,000 in total. You are required to

- (a) Calculate and present the marginal product costs and contribution per unit.
- (b) State which of the following alternative sales mixes you would recommend?
 - (i) 100 units of Product A and 50 units of B.
 - (ii) 50 units of Product A and 80 units of B.
 - (iii) 200 units of Product A only.
 - (iv) 150 units of Product B only.

OR

6. Write short notes on (Any three):

[15]

- (a) Uses of Marginal Costing
- (b) Master Budget
- (c) Merits of Standard Costing
- (d) Limiting Factor

April 2014

Duration : 2Hrs.

Total Marks: 60

- N.B. :**
1. Question Nos. 1 and 2 are compulsory.
 2. Attempt any **one** question from Question Nos. 3 and 4.
 3. Attempt any **one** question from Question Nos. 5 and 6.
 4. **Figures** to the **right** indicate **marks** assigned to the questions.
 5. **Working notes** should form **part of your answer**.

1. ABC furnishes you the following information : (15)

Particulars	First Half of Year ₹	Second Half of Year ₹
Sales	8,10,000	10,26,000
Profit	21,600	64,800

From the above you are required to compute the following assuming that the Fixed Cost remains the same in both the periods.

- (a) P/V ratio.
 - (b) Fixed Cost for the year.
 - (c) Amount of profit or loss when sales are ₹ 16,48,000/-
 - (d) The amount of sales required to earn a profit of ₹ 2,25,000/-
 - (e) Margin of safety for the year.
2. (a) Select correct alternative and rewrite the sentence : (5)
- (i) The classification of Fixed and Variable Cost has a special significance in the preparation of _____.
 - (a) Flexible Budget
 - (b) Cash Budget
 - (c) Capital Budget
 - (d) Zero Based Budget
 - (ii) When Sales Increases, the Break Even Point _____.
 - (a) Increases
 - (b) Decreases
 - (c) Remains Constant
 - (d) None of these
 - (iii) A standard which is established for unaltered for an indefinite period is called _____.
 - (a) Current Standard
 - (b) Ideal Standard
 - (c) Expected Standard
 - (d) Basic Standard
 - (iv) If the activity level is reduced from 80% to 70% the fixed cost _____.
 - (a) Will Increase by 10%
 - (b) Will Decrease by 10%
 - (c) Per Unit will Decrease
 - (d) Per Unit will Increase

- (v) Contribution is _____.
- (a) Fixed Cost + Profit (b) Sales — Variable Cost
(c) Fixed Cost — Loss (d) All of the above

(b) State whether the following statement is True or False and rewrite the sentence : (5)

- (i) Production Budget is calculated from the desired ending inventory and the sales Forecast.
- (ii) In Marginal Costing the price can be fixed on the basis of only Variable Cost.
- (iii) Material Price Variance is the total of Material Yield Variance and Material Mix Variance.
- (iv) Standard Costing technique uses standards for cost and revenues for the purpose of control.
- (v) Cash Budget is a Master Budget.

(c) Match the following : (Rewrite the sentences) (5)

Group A	Group B
1. Sales budget	(a) Profit Region
2. Angle of Incidence	(b) Limiting Factor
3. Key Factor	(c) Total Indirect Cost
4. Break Even Chart	(d) Functional Budget
5. Overhead	(e) Relationship Between Volume, Cost and Profit

3. Following information is available : (15)

	Product 'X' Per Unit ₹	Product 'Y' Per Unit ₹
Direct Material	80	100
Direct Wages	40	50
Variable Overheads	30	50
Selling Price	200	275

Total Fixed overheads ₹ 20,000/-

From the following alternatives which sales mixed will bring higher profits :

- (a) 250 Units of 'X' and 150 Units of 'Y'.
(b) 150 Units of 'X' and 250 Units of 'Y'.
(c) 400 Units of 'X' only.
(d) 400 Units of 'Y' only.
(e) 200 Units of 'X' and 200 Units of 'Y'.

Support your answer with working.

4. The expenses budget for production of 20,000 units at 100% capacity in a factory are given : [15]

	₹
Material	5,00,000
Labour	4,00,000
Factory Overheads (20% Variable)	3,00,000
Office and Administrative (30% Fixed)	2,50,000
Selling Distribution (40% Variable)	1,50,000

Prepare a Flexible Budget at 70% and 90% capacity level.

5. The details are available from the records of Binny Ltd. engaged in Manufacturing Article 'S' for the month ended 31-12-2013. The Standard Data and Actual Data are as follows : [15]

	Standard (100 Units)		Actual (1,000 Units)	
	Quantity	Rate Per Kg.	Quantity	Rate Per Kg.
Material	120 Kg.	₹ 10.00	1,250 Kg.	₹ 9.50
Labour	Hours 90	Rate Per Kg. ₹ 15.00	Hours 875	Rate Per Hr. ₹ 100.00

Calculate :

- Material Cost Variance
 - Material Price Variance
 - Material Usage Variance
 - Labour Rate Variance
 - Labour Efficiency Variance
 - Labour Cost Variance
6. Write short notes on any three of the following : (15)
- Advantages of Budgetary Control
 - Break Even Analysis
 - Absorption Costing Vs. Marginal Costing
 - Fixed Overhead Variance .
 - Importance of Cash Budget

April 2015

Total Marks: 75

- N.B. :** (1) All questions are **compulsory** with internal choice.
 (2) All questions carry equal **marks**.
 (3) Working notes should form part of your answers.

1. (A) State whether the statements are True or False (Rewrite the sentence) (Any 8) **8**
- (i) Marginal cost is a fixed cost.
 - (ii) Key factor is a limiting factor.
 - (iii) A Budget need not be realistic.
 - (iv) Zero base budgeting is based on past budget.
 - (v) Flexible Budget is most practical.
 - (vi) Profit is equal to contribution.
 - (vii) Decision making involves choice of alternatives.
 - (viii) Standard costing is a technique of controlling cost.
 - (ix) Idle time variance is always favourable.
 - (x) Profit = Fixed Cost – Contribution.
1. (B) Multiple choice questions rewrite the sentence (Any 7) **7**
- (i) The budget which is dynamic
 - (a) Fixed Budget
 - (b) Sales Budget
 - (c) Flexible Budget
 - (d) Cash Budget
 - (ii) Production Budget should be prepared in
 - (a) Value only
 - (b) Quantity only
 - (c) Quantity and Value both
 - (d) None of the above
 - (iii) Contribution =
 - (a) Sales – Variable Cost
 - (b) Fixed Cost + Profit
 - (c) Sales × Profit Volume Ratio
 - (d) All of the above
 - (iv) Variable cost
 - (a) Changes per unit
 - (b) Remain fixed
 - (c) None of the above
 - (d) Changes with the change in output
 - (v) The object of budgetary control is
 - (a) Planning
 - (b) Organising
 - (c) Forecasting
 - (d) None of the above

- (vi) Labour time variances =
- (Standard rate – Actual rate) × Standard quantity
 - (Standard rate – Actual rate) × Actual quantity
 - (Standard hours – Actual hours) × Standard rate
 - (Standard hours – Actual hours) × Actual rate
- (vii) A summary of all functional budget is called
- Fixed Budget
 - Flexible Budget
 - Master Budget
 - Overheads Budget
- (viii) BEP is
- Fixed Cost/Profit Volume Ratio
 - Actual Sales + Break-even Sales
 - Margin of Sales – Actual Sales
 - All of the above
- (ix) When preparing a production budget, the quantity to be produced equals to
- Sales Quantity + Opening Stock + Closing Stock
 - Sales Quantity – Opening Stock + Closing Stock
 - Sales Quantity – Opening Stock – Closing Stock
 - Sales Quantity + Opening Stock – Closing Stock
- (x) The cost of product as determined under standard cost system is
- Fixed cost
 - Direct cost
 - Historical cost
 - Pre-determined cost
2. (A) A firm sells 25,000 units at a selling price of ₹ 5 per unit. Its fixed cost is ₹ 40,000 and variable expenses ₹ 50,000. Find out the break-even point for the firm. Also, find out BEP when:

15

- The selling price is increased by 30%
- The fixed cost is increased by 15%
- The fixed cost is decreased by 25%
- The selling price is decreased by 20%

OR

2. A, B and C are three similar plants under same management who want them to be merged for better operation. The details are as under:

15

Plant	A	B	C
Capacity Operated	100%	70%	60%
Turnover (in lakhs)	300	280	180
Variable cost (in lakhs)	200	210	90
Fixed cost (in lakhs)	70	50	62

You are required to find out:

- (a) The capacity of merged plant for break-even.
 (b) The profit at 85% capacity of the merged plant.
 (c) The turnover from the merged plant to give a profit of ₹ 38 lakhs.
3. A factory produces 20,000 units. The budgeted expenses are given below:

15

Particulars	₹ Per Unit
Direct Materials Cost	75
Direct Labour Cost	20
Direct Expenses	25
Variable Production Overheads	15
Fixed Production Overheads (₹ 400,000)	20
Administrative Expenses (Fixed)	10
Selling Expenses (20% Fixed)	15
Distribution Expenses (40% Fixed)	20
Total Cost of Sales per unit	200

Prepare a flexible budget for production of: (a) 15,000 units and (b) 10,000 units.

3. A factory is currently working at 50% capacity and produces 10,000 units. Prepare a Flexible Budget and estimate the profits of the company when it works at 60% and 80% capacity and advise the company. At 60% working, raw material cost increases by 5% and selling price falls by 2%. At 80%, raw materials cost increases by 6% and selling price falls by 4%. At 50% capacity working, the product costs ₹ 180 per unit and is sold at ₹ 200 per unit.

15

The unit cost of ₹ 180 is made up as follows:

Material	₹ 100
Labour	₹ 30
Factory overheads	₹ 30 (40% fixed)
Administrative overheads	₹ 20 (50% fixed)

4. Gemini Chemicals Industries provide the following information from their records. For making 10 kgs of GEMCO, standard material requirements is

15

Material	Quantity (kg)	Rate per kg (₹)
A	8	6
B	4	4

During April 2015, 1,000 kg of GEMCO were produced. The actual consumption of material is as under:

Material	Quantity (kg)	Rate per kg (₹)
A	750	7
B	500	5

Calculate all material variances.

OR

4. The budgeted and the actual sale for a period in respect of three products are given below:

15

Budgeted Figures

Product	Quantity	Price (₹)	Value (₹)
A	1,000	5	5,000
B	750	10	7,500
C	500	15	7,500
	2,250		20,000

Actual

Product	Quantity	Price (₹)	Value (₹)
A	1,200	6	7,200
B	700	9	6,300
C	600	14	8,400
	2,500		21,900

Calculate all sales variances.

5. (A) What is Budget? Explain advantages and limitations of budgets. 8
 (B) What are the limitations of marginal costing? 7

OR

5. Write short note (Any 3) 15
 (a) Absorption Costing vs. Marginal Costing.
 (b) Fixed and Flexible Budget.
 (c) Standard Costing.
 (d) Break even Analysis.
 (e) Decision-making in Marginal Costing.

April 2016

Total Marks: 75

N.B. : (1) All questions are **compulsory**.

- (2) **Figures** to the **right** indicate **full** marks.
 (3) Working note should be part of answer.
 (4) Use of simple calculator is permitted.

1. (A) Select correct option and re-write the sentence. **(Any 8)** **8**
- (i) ABC Ltd. manufactures a single product which it sells for ₹ 50 per unit. Fixed costs are ₹ 80,000 per annum. The contribution to sales ratio is 50%. ABC Ltd.'s break-even point in units is:
- (a) ₹ 3,500 (b) ₹ 3,000
 (c) ₹ 3,200 (d) ₹ 3,400
- (ii) A company plans to produce and sell 5,000 units of product C each month, at the selling price of ₹ 20 per unit. The unit cost comprised of ₹ 8 variable cost and ₹ 6 fixed cost. Calculate the margin of safety as a percentage of planned sales:
- (a) 60% (b) 50%
 (c) 65% (d) 75%
- (iii) A budget that gives a summary of all the functional budgets is known as:
- (a) Capital Budget (b) Flexible Budget
 (c) Master Budget (d) Discretionary Budget
- (iv) The fixed variable cost classification has a special significance in the preparation of:
- (a) Capital Budget (b) Flexible Budget
 (c) Master Budget (d) Cash Budget
- (v) When preparing a production budget, the quantity to be produced equals:
- (a) Sales Quantity + Opening Stock + Closing Stock
 (b) Sales Quantity – Opening Stock + Closing Stock
 (c) Sales Quantity – Opening Stock – Closing Stock
 (d) Sales Quantity + Opening Stock – Closing Stock
- (vi) A job requires 12,000 actual labour hours for completion and it is anticipated that there will be 20% idle time. If the wage rate is ₹ 10 per hour, what is the idle cost for the job?
- (a) ₹ 19,200 (b) ₹ 24,000
 (c) ₹ 28,800 (d) ₹ 30,000

- (vii) Of the four costs shown below which would not be included in the cash budget?
- (a) Depreciation of the fixed asset
 - (b) Office salaries
 - (c) Commission paid to the agents
 - (d) Capital cost of a new computer
- (viii) PG Ltd. makes a single product and is preparing its material usage budget for next year. Each units of product requires 2 kgs of material, and 5,000 units of product are to be produced next year. Opening stock of material is budgeted to be 800 kgs and PG Ltd. budget to increase material stock at the end of next year by 20%. The material usage budget for next year is:
- (a) 8,000 kg
 - (b) 9,840 kg
 - (c) 10,000 kg
 - (d) 10,160 kg
- (ix) If a company uses only one type of material, then following variance cannot be found:
- (a) Material cost variance
 - (b) Material price variance
 - (d) Material usage variance
 - (c) Material yield variance
- (x) Telephone charges is:
- (a) variable cost
 - (b) fixed cost
 - (c) semi-variable cost
 - (d) none of the above
1. (B) State whether following statements are **true** or **false** (any 7) 7
- (i) Equal emphasis should be laid on favourable and unfavourable variances.
 - (ii) Material yield variance is the difference between the standard yield specified and the actual yield obtained.
 - (iii) Analysis of variances is done in order to determined the reasons for increase or decrease in profit.
 - (iv) A system of budgetary control cannot be used in an organisation when standard costing is being used.
 - (v) Budgets are always prepared for past.
 - (vi) Forecast and budget are one and the same.
 - (vii) The relationship between contribution and turnover is represented in the form of profit volume ratio.
 - (viii) At break-even point, fixed cost plus profit is equal to total sales.
 - (ix) Margin of Safety = Break-even Sales + Fixed Cost.
 - (x) A high margin of safety usually indicates high fixed overheads.
2. The following information is obtained from a company for January: 15
- | | |
|----------------|----------|
| Sales | ₹ 20,000 |
| Variable Costs | ₹ 10,000 |

Fixed Costs ₹ 6,000

- (i) Find P/V Ratio, Break-even point and Margin of Safety at this level.
- (ii) Also find effect of the following individually on BEP sales:
 - (a) 20% decrease in fixed cost
 - (b) 10% increase in fixed cost
 - (c) 10% decrease in variable cost
 - (d) 10% increase in selling price
 - (e) 10% increase in variable cost and selling price both

OR

2. M/s. Alok Industries has given the following details:

Particulars	Product "X"	Product "Y"	Product "Z"
Units Budgeted to be Produced and Sold	1,800	3,000	1,200
Selling Price Per Unit (₹)	60	55	50
Requirements Per Unit:			
Direct Materials	5 kg.	3 kg.	4 kg.
Direct Labour	4 hrs.	3 hrs.	4 hrs.
Variable Overheads	₹ 7	₹ 13	₹ 8
Fixed Overheads	₹ 10	₹ 10	₹ 10
Cost of Direct Material Per Kg.	₹ 4	₹ 4	₹ 4
Direct Labour Hour Rate	₹ 2	₹ 2	₹ 2
Maximum Possible Units of Sales	4,000	5,000	1,500

Find the most profitable product mix and prepare a statement of profitability of the product mix.

All the three products are produced from the same direct material using the same type of machines and labour. Direct Material, which is the key factor, is limited to 36,000 kg.

3. M/s. Jayshree Enterprises is currently working at 50% capacity and produces 10,000 units. At 60% working, raw material cost increases by 2% and selling price falls by 2%. At 80% working, raw material cost increases by 5% and selling price by 5%. At 50% capacity working, the product costs ₹ 18 per unit and is sold at ₹ 20 per unit. **(15)**

The unit cost of ₹ 18 is made up as following:

Material	₹ 10
Wages	₹ 03
Factory Overheads	₹ 03 (40% Fixed)
Administration Overheads	₹ 02 (50% Fixed)

Prepare a statement showing the estimated profit of the business when it is operated at 60% and 80% capacity.

It may be noted the fixed overhead remain constant upto 100% capacity. Increase in raw material cost and decrease in selling price are to be calculated with reference to the figure given for 50% capacity usage.

OR

3. ABC Foods Products Limited has prepared the following Sales Budget for the first five months of 2016. (15)

Sales Budget (in Units)

January	10,800
February	15,600
March	12,200
April	10,400
May	9,800

The inventory of finished products at the end of every month is to be equal to 25% of the sales estimate for the next month. On 1st January 2016, there were 2,700 units of product in hand. There is no work-in-process at the end of any month.

Every unit of product requires two types of materials in the following quantities: Material A: 4 kg and Material B: 5 kg.

Material equal to one-half of the next month's production are to be in hand at the end of every month. This requirement was met on 1st January, 2016. Budgeted prices for the purchase of materials are: Material A: ₹ 3 per kg and Material B: ₹ 2 per kg.

Prepare Materials Consumption Budget and Purchase Budget (quantity and value) for first quarter of 2016 showing the quantities of each type of material to be purchased every month.

4. The budgeted and the actual sale for a period in respect of three products are given below: (15)

Budgeted Figures

Product	Quantity	Price (₹)	Value (₹)
A	1,000	5	5,000
B	750	10	7,500
C	500	15	7,500
	2,250		20,000

Actual

Product	Quantity	Price (₹)	Value (₹)
A	1,200	6	7,200
B	700	9	6,300
C	600	14	8,400
	2,500		21,900

Calculate all sales variances.

OR

4. Calculate all labour variance from the following data: (15)

Particulars	Standard Hours	Standard Hourly Rate	Actual Hours	Actual Hourly Rate
Skilled Labour	2880	20	1760	25
Semi-skilled Labour	1920	10	2640	5
Total	4800		4400	
Output	108 kg		90 kg	

5. (A) What is marginal costing? Explain Break-even chart in detail. (8)
 (B) What is standard costing? Explain Material variances in detail. (7)

OR

5. Write Short Notes (Any 03) (15)
- P/V Ratio
 - Fixed overheads variances
 - Master Budget
 - Advantages of Budgetary Control
 - Limiting factor

Solution

1. (A) (i) 3200 units, (ii) 50%, (iii) Master Budget, (iv) Flexible Budget, (v) Sales Quantity – Opening Stock + Closing Stock, (vi) ₹ 24,000, (vii) Depreciation of the fixed assets, (viii) 10160 kg, (ix) Material Yield Variance, (x) Semi-variable cost.
 (B) False: (ii), (v), (vi), (viii), (ix), (x); True: (i), (iii), (iv), (vii).

2. Marks in the Brackets

		20% Decrease in FC	10% Increase in FC	10% Decrease in VC	10% Increase in SP	10% Increase in VC and SP
Sales	20000			20000	22000	22000
(-) Variable Cost	10000			9000	10000	11000
Contribution	10000			11000	12000	11000
(-) FC	6000			6000		6000
Profit	4000			5000		5000
P/V Ratio = C/S * 100	50%	50%	50%	55%	54.55%	50%
BEP in ₹ = FC/P/V ratio	12000	9600	13200	10909	11000	12000
MOS = AS - BEP	8000					

2. Direct Material is Key Factor

X	=	25/5 kg	=	5 Rank II
Y	=	24/3 kg	=	8 Rank I
Z	=	18/4 kg	=	4.5 Rank III

Statement of Product Mix

X	4000 units * 5	20000
	5000 units * 3	15000
	250 units * 4	1000
		<u>36,000</u>
Contribution	X (4000 * 25)	1,00,000
	Y (5000 * 24)	1,20,000
	Z (250 * 18)	4,500
		<u>2,24,500</u>
Fixed Cost		<u>60,000</u>
Profit		<u>1,64,500</u>

Particulars	50%		60%		80%	
	1000 units		12000 units		16000 units	
Sales	20	200000	19.60	235200	21	336000
(-) COGS:						
Material	10	100000	10.20	122400	10.50	168000
Wages	3	30000	3	36000	3	48000
Factory OHS:						
Fixed	1.20	12000	1	12000	0.75	12000
Variable	1.80	18000	1.80	21600	1.80	28800

Administration OHS:						
Fixed	1	10000	0.83	10000	0.625	10000
Variable	1	10000	1	12000	1	16000
Profit	2	20000	1.77	21200	3.325	53200

(Alternate: For 80% if students have taken decrease in selling price by 5% give marks profit will be ₹ 21,200.)

3.

Production budget in units

Particulars	January	February	March
Sales	10,800	15,600	12,200
<i>Add:</i> Closing Stock	3,900	3,050	2,600
<i>Less:</i> Opening Stock	2,700	3,900	3,050
Production Units	12,000	14,750	11,750

Material	January (12000 units)	February (14750 units)	March (11750 units)
A (4 kg per unit)	48,000	59,000	47,000
B (5 kg per unit)	60,000	73,750	58,750

Purchase Budget for Material A (in ₹)

Particulars	January	February	March
Consumption Quantity	48,000	59,000	47,000
<i>Add:</i> Closing Stock	29,500	23,500	20,500
<i>Less:</i> Opening Stock	24,000	29,500	23,500
Purchase Quantity	53,500	53,000	44,000
Price per kg	₹ 3	₹ 3	₹ 3
Purchase Amount (₹)	1,60,500	1,59,000	1,32,000

Purchase Budget for Material B (in ₹)

Particulars	January	February	March
Consumption quantity	60,000	73,750	58,750
<i>Add:</i> Closing Stock	36,875	29,375	25,625
<i>Less:</i> Opening Stock	30,000	36,875	29,375
Purchase Quantity	66,875	66,250	55,000
Price per kg	₹ 2	₹ 2	₹ 2
Purchase Amount (₹)	1,33,750	1,32,500 (0.5)	1,10,000

4. Sales Variance

$$\begin{aligned}
 \text{A} &= (1200 * 6) - (1000 * 5) = 2200 \text{ (F)} \\
 \text{B} &= (700 * 9) - (750 * 10) = 1200 \text{ (A)}
 \end{aligned}$$

C	=	$(600 * 14) - (500 * 15)$	=	900 (F)
				1900 (F)
Sales Price Variance	=	$(AP - SP) * AQ$		
A	=	$(6 - 5) * 1200$	=	1200 (F)
B	=	$(9 - 10) * 700$	=	700 (A)
C	=	$(14 - 15) * 600$	=	600 (A)
				100 (A)
Sales Volume Variance	=	$(AQ - SQ) * SP$		
A	=	$(1200 - 1000) * 5$	=	1000 (F)
B	=	$(700 - 750) * 10$	=	500 (A)
C	=	$(600 - 500) * 15$	=	1500 (F)
				2000 (F)
Sales Mix Variance	=	$(AQ - RSQ) * SP$		
A	=	$(1200 - 1111) * 5$	=	445 (F)
B	=	$(700 - 833) * 10$	=	1330 (A)
C	=	$(600 - 556) * 15$	=	660 (F)
				225 (A)
Sales Sub-volume Variance	=	$(RSQ - SQ) * SP$		
A	=	$(1111 - 1000) * 5$	=	555 (F)
B	=	$(833 - 750) * 10$	=	830 (F)
C	=	$(556 - 500) * 15$	=	840 (F)
				2225 (F)
4. Labour Variance				
Skilled	=	$(2400 * 20) - (1760 * 25)$	=	4000 (F)
Semi-skilled	=	$(1600 * 10) - (2640 * 5)$	=	2800 (F)
				6800 (F)
LRV	=	$(SR - AR) * AH$		
Skilled	=	$(20 - 25) * 1760$	=	8800 (A)
				13200 (F)
				4400 (F)
LTV	=	$(SH - AH) * SR$		
Skilled	=	$(2400 - 1760) * 20$	=	12800 (F)
Semi-skilled	=	$(1600 - 2640) * 10$	=	10400 (A)
				2400 (F)

LMV	=	$(RH - AH) * SR$	
Skilled	=	$(2640 - 1760) * 20$	= 17600 (F)
Semi-skilled	=	$(1760 - 2640) * 10$	= 8800 (A)
			8800 (F)
LYV	=	$(SH - RH) * SR$	
Skilled	=	$(2400 - 2640) * 20$	= 4800 (A)
Semi-skilled	=	$(1600 - 1760) * 10$	= 1600 (A)
			6400 (A)

April 2017

Duration : 2 ½ Hrs.

Total Marks: 75

Please check whether you have got the right question paper.

- N.B. :**
1. All questions are compulsory with internal choice.
 2. Figures to the right indicate full marks.
 3. Working notes should be part of your answer
 4. Use of simple calculator is permitted

Q.1 A. Match the following (Any 08) [Rewrite the sentence] (08)

Group 'A'	Group 'B'
1. Labour efficiency Variance	(a) Pre-determined cost
2. Imputed cost	(b) Limiting factor
3. Profit	(c) No. Profit, No loss stage
4. Idle Time Variances	(d) (Standard Hours — Actual hours) X Standard Rate
5. Standard Cost	(e) Notional Cost
6. Marginal Cost	(f) Remains unchanged irrespective of the level of capacity of Volume
7. Master Budget	(g) Contribution — Fixed Cost
8. Fixed Budget	(h) Always Unfavourable
9. BEP	(i) Prime Cost + Variable overheads
10. Key factor	(j) Summary of all Functional Budgets

B. State whether the following statement is True / False & Rewrite the sentence (Any 07) (07)

1. Variable overhead variance is a difference between standard overheads and actual overheads.
2. In make or buy decision only Marginal cost is relevant.
3. P/V Ratio shows the relationship between contribution and sales.
4. Budget is prepared for the future period.
5. Cash Budget shows budgeted receipts and payments.
6. Excess of actual cost over standard cost is a favourable variance.
7. Decision to accept or reject export order depends on fixed cost only.
8. Under Marginal costing cost is classified on the basis of functions.
9. A budget is expressed in financial terms only.
10. Variable cost remains fixed irrespective of Level of Activity.

2. The Sales and profits of two years were as follows: (15)

Year ending 31 st March	Sales ₹	Profit ₹
2016	4,00,000	40,000
2017	6,00,000	80,000

Calculate :

- Profit-volume (P/V) Ratio
- Fixed cost .
- Break Even Point
- If the company wants to have a profit of ₹ 15,000 what should be the level of sales?
- Profit when sales are 7,80,000
- Revised BEP if Fixed Cost increase by 25%.

OR

2. A, B and C are three similar plants under the same management who want them to be merged for better operation. (15)

The following particulars are available

Plant	A	B	C
Capacity Operated	100%	60%	40%
	₹ in lakhs	₹ in lakhs	₹ in lakhs
Turnover	300	300	80
Variable Cost	180	210	60
Fixed	70	50	62

You are required to ascertain :

- The capacity of the merged plant for break even.
- The profit or loss at 80% capacity of merged plant
- The turnover from the merged plant to give profit of ₹ 30 lakhs.

3. From the following information given prepare the budget for 80% level of activity (15)

Level of Activity	50%	60%
No. of Units	25,000	30,000
Direct Material ₹	2,00,000	2,40,000
Direct Wages ₹	75,000	90,000
Factory overheads ₹	2,00,000	2,05,000
Office and Administration ₹	3,00,000	3,00,000
Selling and Distribution ₹	2,50,000	2,70,000

Profit is 20% on sales.

OR

3. The following data is available of a manufacturing company for a year. (15)

Fixed Expenses	₹ “000”
Salaries and Wages	1,520
Rent, Rates and Taxes	1,056
Depreciation	1,184
Sundry Administration Expenses	1,040

Variable Expenses		Semi-variable expenses	
At 50% Capacity	₹ “000”	At 50% Capacity	₹ “000”
Materials	3,472	Repairs and Maintenance	560
Labour	3,264	Indirect Labour	1,264
Other Expenses	1,264	Salesman Salaries	608
		Sundry Administration Expenses	448

Semi-variable expenses remain constant between 45% and 65% of capacity, increasing by 10 between 66% and 80% capacity and by 20% between 80% and 100% capacity.

Sales at various Level are	₹ “000”
50% of Capacity	16,000
60% of Capacity	19,200
75% of Capacity	24,000
90% of Capacity	28,800
100% of Capacity	32,000

Prepare a flexible budget for the year and forecast the profit at 50%, 75% and 100% Capacity.

4. From the following information about sales calculate: (15)

- (a) Sales Value Variance (b) Sales Price Variance
(c) Sales Volume Variance (d) Sales Mixed Variance
(e) Sales Quantity Variance

Product	Budgeted		Actual	
	Units	Rate ₹	Units	Rate ₹
X	25,000	10	48,000	11
Y	35,000	11	36,000	10
Z	40,000	12	36,000	13

OR

4. From the data given below compute all Material variance [15]

Product	Budgeted Per Unit		Actual Per Unit	
	Kg.	Rate ₹	Kg.	Rate ₹
L	5	20	7	22
M	8	30	5	28
N	7	40	8	41

5. A. State the steps involved in budgetary control system? (08)

B. What are the benefits of Standard Costing. (07)

OR

5. Write short notes (Any 3) (15)

- Labour variance
- Break even chart
- Absorption costing vs. Marginal Costing
- Zero base budget
- Decision making in marginal costing

Solution

1. A. Ans.

(1 — d), (2 — e), (3 — g), (4 — h), (5 — a), (6 — i), (7 — j), (8 — f), (9 — c), (10 — b)

1. B. Ans. True : 1, 2, 3, 4, 5

False : 6, 7, 8, 9, 10

2. Ans. 1. P/V ratio 20% 2. Fixed cost 40,000 3. BEP ₹ 2,00,000 4. Sales to Earn the profit of ₹ 15,000 = ₹ 2,75,000 5. Profit when the sales ₹ 7,80,000 = ₹ 1,16,000
6. Revised BEP if fixed cost increase by 25% = ₹ 2,50,000 .

2. Solution

Particulars	A	B	C	Total
Sales	300	500	200	1000
VC	180	350	150	680
Cont	120	150	50	320
FC	70	50	62	182
Profit/(Loss)	50	100	(12)	138

- (a) BEP of merged plant = ₹ 568.75 lakhs
 (b) Profit or loss at 80% capacity = ₹ 74 lakhs
 (c) Turnover to give the profit of T 30 lakhs = ₹ 662.50 lakhs

3. Solution.

Particulars	50% 25,000	60% 30,000	80% 40,000
Direct Material	2,00,000	2,40,000	3,20,000
Direct Wages	75,000	90,000	1,20,000
Variable Factory Overheads	25,000	30,000	40,000
Variable Selling and Distribution	1,00,000	1,20,000	1,60,000
Total Variable Cost	4,00,000	4,80,000	6,40,000
Office and Administration	3,00,000	3,00,000	3,00,000
Factory Overheads	1,75,000	1,75,000	1,75,000
Selling and Distribution	1,50,000	1,50,000	1,50,000
Total Fixed Cost	6,25,000	6,25,000	6,25,000
Total Cost	10,25,000	11,05,000	12,65,000
Profit	2,56,250	2,76,250	3,16,250
Sales	12,81,250	13,81,250	15,81,250

Profit is 20% on Sales

3. Solution

Particulars	50%	75%	100%
Material	3,472	5,208	6,944
Labour	3,264	4,896	6,528
Other Expenses	1,264	1,896	2,528
Total Variable cost	8,000	12,000	16,000
Repairs & Maintenance	560	616	672
Indirect Labour	1,264	1,390.4	1,516.8
Salesman Salaries	608	668.8	729.6
Sundry Administration Expenses	5376	448	492.8
Total Semi variable	2,880	3,168	3,456
Total Fixed Cost	4,800	4,800	4,800
Total Cost	15,680	19,968	24,256
Profit	320	4,032	7,744
Sales	16,000	24,000	32,000

4. Solution**Sales Variance**

1. Sales Value Variance $X = (2,50,000 - 5,28,000) = 2,78,000 \text{ F}$
 $Y = (3,85,000 - 3,60,000) = 25,000 \text{ A}$
 $Z = (4,80,000 - 4,68,000) = 12,000 \text{ A}$ **Total 2,41,000 F**
2. Sales price variance $X = (10 - 11) \times 48,000 = 48,000 \text{ F}$
 $Y = (11 - 10) \times 36,000 = 36,000 \text{ A}$
 $Z = (12 - 13) \times 36,000 = 36,000 \text{ F}$ **Total 48,000 F**
3. Sales Volume Variance $X = (25,000 - 48,000) \times 10 = 2,30,000 \text{ F}$
 $Y = (35,000 - 36,000) \times 11 = 11,000 \text{ F}$
 $Z = (40,000 - 36,000) \times 12 = 48,000 \text{ A}$ **Total 1,93,000 F**
4. Sales Quantity Variance $(1,00,000 - 1,20,000) \times 11.15 = 2,23,000 \text{ F}$
5. Sales Mix Variance $X = (30,000 - 48,000) \times 10 = 1,80,000 \text{ F}$
 $Y = (42,000 - 36,000) \times 11 = 66,000 \text{ A}$
 $Z = (48,000 - 36,000) \times 12 = 1,44,000 \text{ A}$ **Total 30,000 A**

4. Solution

1. MCV $L = 100 - 154 = 54 \text{ A}$
 $M = 240 - 140 = 100 \text{ F}$
 $N = 280 - 328 = 48 \text{ A}$ **Total = 2A**
2. MPV $L = (20 - 22) \times 7 = 14 \text{ A}$
 $M = (30 - 28) \times 5 = 10 \text{ F}$
 $N = (40 - 41) \times 8 = 8 \text{ A}$ **Total = 12A**
3. MUV $L = (5 - 7) \times 20 = 40 \text{ A}$
 $M = (8 - 5) \times 30 = 90 \text{ F}$
 $N = (7 - 8) \times 40 = 40 \text{ A}$ **Total = 10F**
4. MYV Zero
5. MMV Same as MUV

